

# BJC-7100

# SERVICE MANUAL

REVISION 0

**Canon**

OCT. 1998

**QY8-1360-000**

1098 AB 5.00-0

# BJC-7100

# SERVICE MANUAL

**Canon**

## **Target Readers**

This manual is published by Canon Inc. for qualified persons and contains the necessary technical information for technical theory, installation, maintenance, and repair of products. This manual covers all localities where the products are sold. For this reason, it may contain information that does not apply to your locality.

## **Revisions**

This manual may include technical inaccuracies or typographical errors due to improvements or changes in the products. When amendments are made to the content of this manual, Canon will issue technical information as the need arises. In the event of major alterations to the content of this manual over a long or short period, Canon will publish a revised version of the manual.

**The following paragraph does not apply to any countries where such provisions are inconsistent with the local law.**

## **Trademarks**

The product names and company names appearing in this manual are the registered trademarks or trademarks of the individual companies.

## **Copyright**

This manual is copyrighted and all rights reserved. Under the copyright laws, this manual may not be copied, reproduced, or translated into other languages, in whole or in part, without the express written consent of Canon Inc. except in the case of internal business use.

**Copyright © 1998 by Canon Inc.**

**CANON INC.**

**BJ Products Quality Support Dept.**

**16-1, Shimonoge 3-chome, Takatsu-ku, Kawasaki, Kanagawa 213, Japan**

This manual was produced on an Apple Macintosh™ Power Mac 7300/180 personal computer and Apple LaserWriter™ II NTX-J laser beam printer; final pages were printed on Agfa SelectSet Avantra 25.

A YANO 640MO drive system NJ640MO with MITSUBISHI MO disk cartridge MR230M1 were used for storing large volumes of page layout and graphic data for this manual.

All graphics were produced with MACROMEDIA FREEHAND™ 7.0J.

All documents and all page layouts were created with QuarkXPress™ 3.3J.

# I. ABOUT THIS MANUAL

This manual is divided into five parts containing the information required for servicing the BJC-7100 printer.

## *Part 1: Safety and Precautions*

This part contains information on how to service the unit safely. It is very important, and must be read.

## *Part 2: Product Specifications*

This part outlines the product and its specifications.

## *Part 3: Operating Instructions*

This part explains how to operate the unit properly, how it is installed, and how to use the service mode.

## *Part 4: Technical Reference*

This part outlines the unit operation giving a technically.

## *Part 5: Maintenance*

This part explains maintenance of the unit. It includes details of disassembly/assembly, adjustments required when assembling, troubleshooting procedures, and wiring/circuit diagrams, etc.



---

This manual does not contain complete information required for disassembling and assembling the BJC-5500 printer. Please also refer to the separate Parts Catalog.

---

## II. TABLE OF CONTENTS

	<i>Part 1: SAFETY AND PRECAUTIONS</i>
1 - 1	1. SAFETY PRECAUTIONS
1 - 1	1.1 Moving Parts
1 - 2	1.2 Front Cover
1 - 3	1.3 Ink Stains
1 - 3	1.3.1 Ink path
1 - 4	1.3.2 Ink mist
1 - 5	1.4 Live Parts
1 - 6	1.5 BJ Cartridge Metal Plate
1 - 7	2. MACHINE PRECAUTIONS
1 - 7	2.1 BJ Cartridge Handling
1 - 7	2.1.1 Unpacking the BJ cartridge
1 - 7	2.1.2 BJ cartridge protection
1 - 8	2.1.3 Power on/off
1 - 8	2.1.4 When not using the printer
1 - 9	2.1.5 Ink electroconductivity
1 - 9	2.2 Ink Tank Handling
1 - 9	2.2.1 Unpacking the ink tank
1 - 9	2.2.2 Preventing clogging
1 -10	2.3 Printer Handling
1 -10	2.3.1 Spurs
1 -10	2.3.2 Damage due to static electricity
1 -11	2.3.3 Ink Leakage and dry-out
1 -11	2.3.4 Carrying the printer
1 -12	3. NOTES ON SERVICING
1 -12	3.1 EEPROM Data
1 -13	3.2 Service Mode of Printer Driver
1 -13	3.3 Protecting the Power Supply
1 -14	3.4 Static Electricity
1 -15	3.5 Disassembly and Assembly
1 -15	3.5.1 Parts that cannot be disassembled
1 -15	3.5.2 Parts requiring careful attention during disassembly and assembly
1 -15	3.6 Self-Diagnosis
	<i>Part 2: PRODUCT SPECIFICATIONS</i>
2 - 1	1. PRODUCT OUTLINE
2 - 1	1.1 Outline
2 - 2	1.2 Features
2 - 3	1.3 BJ Cartridge
2 - 3	1.3.1 Black BJ cartridge (BC-60)
2 - 4	1.3.2 Photo BJ cartridge (BC-62e Photo)
2 - 5	1.3.3 Color BJ cartridge (BC-61)
2 - 5	1.3.4 BJ cartridge vs print mode
2 - 6	1.4 SB-60 BJ Cartridge Container
2 - 6	1.5 Consumables
2 - 6	1.5.1 BJ cartridge
2 - 6	1.5.2 Ink tank
2 - 7	2. SPECIFICATIONS
2 - 7	2.1 General Specifications
2 -10	2.2 Paper Specifications
2 -10	2.2.1 Paper types

Page	
2 -11	2.2.2 Printing range
2 -12	2.3 Interface Specifications

### ***Part 3: OPERATING INSTRUCTIONS***

3 - 1	1. PRINTER SETUP
3 - 1	1.1 Unpacking
3 - 2	1.2 Installation Location
3 - 3	1.3 Installation
3 - 3	1.3.1 Connecting the interface cable
3 - 3	1.3.2 Connecting the power supply
3 - 4	1.3.3 Installing the BJ cartridge
3 - 6	1.3.4 Replacing the ink tanks
3 - 7	1.3.5 Cartridge container [SB-60]
3 - 8	1.4 Turning Printer Power On and Off
3 - 8	1.4.1 Turning the power on
3 - 8	1.4.2 Turning the power off
3 - 9	1.5 Loading Printer Paper
3 -10	1.6 Names of Parts and Their Functions
3 -12	2. TRANSPORTING THE PRINTER
3 -12	2.1 Transporting the Printer
3 -13	2.2 Manual Capping
3 -14	3. PRINTER SERVICING FUNCTIONS
3 -14	3.1 Error Indications
3 -14	3.1.1 Operator call errors
3 -15	3.1.2 Service calls
3 -16	3.2 Warning Indications
3 -17	3.3 Function Settings
3 -17	3.3.1 Items set by control function
3 -18	3.3.2 Service mode of printer driver
3 -19	3.4 EEPROM
3 -19	3.5 Cleaning the BJ Cartridge
3 -20	3.6 Test Printout
3 -20	3.7 Pickup Roller Cleaning Function (HR-101)
3 -21	3.8 Service Mode
3 -22	3.8.1 Final factory test pattern
3 -22	3.8.2 Resetting EEPROM data
3 -23	3.8.3 Printing EEPROM data
3 -23	3.8.4 Setting destination country
3 -24	3.8.5 Other Function

### ***Part 4: TECHNICAL REFERENCE***

4 - 1	1. OVERVIEW
4 - 1	1.1 Printer Block Diagram
4 - 2	1.2 Initial Flowchart
4 - 3	1.3 Print Signal Sequence
4 - 4	1.4 BJ Cartridge Drive
4 - 4	1.4.1 Print drive control
4 - 5	1.5 Power-Off Sequence Flowchart
4 - 6	2. FIRMWARE
4 - 6	2.1 Interface
4 - 6	2.1.1 Compatible mode
4 - 7	2.1.2 Nibble mode
4 - 7	2.1.3 ECP mode

Page	
4 - 8	2.2 Print Modes
4 - 9	2.2.1 Plain paper optimized printing mode (P-POP)
4 - 9	2.2.2 Economy print mode (Draft mode)
4 - 9	2.2.3 Standard mode
4 - 9	2.2.4 High quality and fine mode
4 -10	2.2.5 Print mode settings
4 -11	2.3 Smoothing Function
4 -11	2.4 Print Optimization Controls
4 -11	2.4.1 Power monitor
4 -11	2.4.2 Head sticking prevention
4 -11	2.4.3 Ink smear prevention
4 -12	2.5 Head Overheat Protection
4 -13	3. PRINTER'S MECHANICAL SYSTEM
4 -13	3.1 Overview
4 -14	3.1.1 Structure of printer's mechanical system
4 -15	3.2 BJ Cartridge
4 -15	3.2.1 BJ Cartridge structure
4 -19	3.2.2 Structure of BJ head unit
4 -21	3.2.3 Nozzle arrays
4 -22	3.2.4 Signal contacts
4 -24	3.2.5 Drive circuit
4 -28	3.2.6 BJ cartridge detection
4 -29	3.3 Purge Unit
4 -29	3.3.1 Function of purge unit
4 -30	3.3.2 Structure of purge unit
4 -33	3.4 Carriage
4 -33	3.4.1 Carriage functions
4 -34	3.4.2 Carriage structure
4 -36	3.5 Paper Feed/Sheet Feeder Mechanism
4 -36	3.5.1 Paper feed/sheet feeder mechanism functions
4 -38	3.5.2 Paper feed/sheet feeder mechanism structure
4 -39	4. PRINTER ELECTRICAL SYSTEM
4 -39	4.1 Overview of Printer Electrical System
4 -40	4.2 Logic
4 -40	4.2.1 Logic block diagram
4 -41	4.2.2 Logic components
4 -45	4.3 Electrical System
4 -45	4.3.1 Input power supply (AC adaptor)
4 -45	4.3.2 Output voltages
4 -46	5. DETECTION FUNCTIONS
4 -46	5.1 Sensor-based Detection Functions
4 -48	5.2 Miscellaneous Detection Functions
4 -48	5.2.1 Waste-ink amount detection
4 -48	5.2.2 BJ cartridge detection
4 -48	5.2.3 Ink-out detection

### *Part 5: MAINTENANCE*

5 - 1	1. MAINTENANCE
5 - 1	1.1 Parts for Periodic Replacement
5 - 1	1.2 Consumable Parts
5 - 1	1.3 Consumables
5 - 1	1.4 Periodic Maintenance
5 - 2	2. SERVICING TOOLS



Page	
5 - 2	2.1 List of Tools
5 - 3	3. APPLYING GREASE
5 - 4	4. DISASSEMBLY AND REASSEMBLY
5 - 4	4.1 Disassembly and Reassembly
5 - 4	4.2 Notes on Disassembly and Reassembly
5 - 4	4.2.1 Main cover
5 - 4	4.2.2 Carriage unit
5 - 5	4.2.3 Bearings at ends of support shaft
5 - 5	4.2.4 Purge unit and bottom case assembly
5 - 5	4.2.5 Securing idler pulley assembly screw
5 - 6	4.3 Waste Ink Absorbers
5 - 7	4.4 Assembling the Chassis
5 - 8	5. ADJUSTMENTS
5 - 8	5.1 Adjustment Locations
5 - 8	5.1.1 Adjusting registration
5 - 8	5.1.2 Checking and adjusting the head gap
5 -13	6. TROUBLESHOOTING
5 -13	6.1 Troubleshooting Overview
5 -13	6.1.1 Overview
5 -13	6.1.2 Troubleshooting cautions
5 -14	6.2 Diagnosis
5 -14	6.2.1 Diagnostic flow
5 -16	6.2.2 Action
5 -37	7. CONNECTOR LAYOUT AND SIGNAL ASSIGNMENT
5 -37	7.1 Logic Board
5 -39	7.2 Carriage Board
5 -44	8. CIRCUIT DIAGRAMS
5 -44	8.1 Parts Layout
5 -44	8.1.1 Logic board
5 -45	8.1.2 Carriage board
5 -47	8.2 Circuit Diagrams
5 -47	8.2.1 Logic board

## III. ILLUSTRATION INDEX

	<b><i>Part 1: SAFETY AND PRECAUTIONS</i></b>	
1 - 1	Figure 1 - 1	The Printer's Moving Parts
1 - 2	Figure 1 - 2	Front Cover
1 - 3	Figure 1 - 3	Ink Path
1 - 4	Figure 1 - 4	BC-62e Photo and BC-61
1 - 4	Figure 1 - 5	Ink Mist
1 - 5	Figure 1 - 6	AC Adapter
1 - 6	Figure 1 - 7	BJ Cartridge Metal Plate
1 - 7	Figure 1 - 8	Removing the BJ Cartridge Cap and Tape
1 - 8	Figure 1 - 9	BJ Cartridges
1 - 9	Figure 1 -10	Removing the Ink Tank Cap
1 - 9	Figure 1 -11	The Ink Outlets on Ink Tank
1 -10	Figure 1 -12	Spurs
1 -10	Figure 1 -13	Contacts
1 -11	Figure 1 -14	Capping Position
1 -11	Figure 1 -15	Carrying the Printer
1 -13	Figure 1 -16	Protecting the Power Supply
1 -14	Figure 1 -17	Electrical System of Printer
1 -15	Figure 1 -18	Parts that Cannot be Disassembled
	<b><i>Part 2: PRODUCT SPECIFICATIONS</i></b>	
2 - 1	Figure 2 - 1	Printer Appearance
2 - 3	Figure 2 - 2	Black BJ Cartridge (BC-60)
2 - 4	Figure 2 - 3	Photo BJ Cartridge (BC-62e Photo)
2 - 5	Figure 2 - 4	Color BJ Cartridge (BC-61)
2 - 6	Figure 2 - 5	BJ Cartridge (SB-60)
2 - 6	Figure 2 - 6	Ink Tanks
2 -11	Figure 2 - 7	Printing Area
2 -18	Figure 2 - 8	Compatible Mode
2 -18	Figure 2 - 9	Nibble Mode
2 -18	Figure 2 -10	ECP Mode
	<b><i>Part 3: OPERATING INSTRUCTIONS</i></b>	
3 - 1	Figure 3 - 1	Packaging
3 - 2	Figure 3 - 2	Printer Dimensions
3 - 3	Figure 3 - 3	Connecting the Interface Cable
3 - 3	Figure 3 - 4	Connecting the Power Supply
3 - 4	Figure 3 - 5	Removing Cap and Tape from BJ Cartridge
3 - 4	Figure 3 - 6	Installing BJ Cartridges
3 - 5	Figure 3 - 7	Checking Print Head Alignment
3 - 6	Figure 3 - 8	Replacing the Ink Tank
3 - 6	Figure 3 - 9	Removing Protective Cap from Ink Tank
3 - 7	Figure 3 -10	Cartridge Container SB-60
3 - 8	Figure 3 -11	Incorrect Method of Powering Off
3 - 9	Figure 3 -12	Paper Settings
3 -10	Figure 3 -13	Names of Parts and Their Functions (1)
3 -11	Figure 3 -14	Names of Parts and Their Functions (2)
3 -12	Figure 3 -15	Transporting the Printer
3 -13	Figure 3 -16	Manual Capping Method
3 -14	Figure 3 -17	Control Panel
3 -17	Figure 3 -18	Windows 95 Driver Control Sheet (Sample)

Page		
3 -18	Figure 3 -19	Hidden Control Sheet (Sample)
3 -20	Figure 3 -20	Nozzle Check Pattern (Sample)
3 -22	Figure 3 -21	Service Mode Test Print (Sample)
3 -23	Figure 3 -22	EEPROM Data Print (Sample)

#### *Part 4: TECHNICAL REFERENCE*

4 - 1	Figure 4 - 1	Printer Block Diagram
4 - 2	Figure 4 - 2	Flowchart of Initialization Sequence
4 - 3	Figure 4 - 3	Print Signal Sequence
4 - 5	Figure 4 - 4	Power-Off Sequence Flowchart
4 - 6	Figure 4 - 5	Bidirectional Centronics Specifications Selection Sequence
4 - 6	Figure 4 - 6	Interface Timing (Compatible Mode)
4 - 7	Figure 4 - 7	Interface Timing (Nibble Mode)
4 - 7	Figure 4 - 8	Interface Timing (ECP Mode)
4 - 9	Figure 4 - 9	Photo Print Mode (Image)
4 -10	Figure 4 -10	Print Mode Main Sheet (Sample)
4 -11	Figure 4 -11	Print Mode Detail Quality Sheet (Sample)
4 -13	Figure 4 -12	Printer's Mechanical System
4 -15	Figure 4 -13	Structure of BC-60
4 -16	Figure 4 -14	Structure of BC-61
4 -17	Figure 4 -15	Structure of BC-62e Photo
4 -19	Figure 4 -16	Structure of BC-60 BJ Head Unit
4 -19	Figure 4 -17	Structure of BC-61 BJ Head Unit
4 -20	Figure 4 -18	Structure of BC-62e Photo BJ Head Unit
4 -21	Figure 4 -19	Nozzle Arrays
4 -22	Figure 4 -20	Signal Contacts
4 -24	Figure 4 -21	Block Diagram of BC-60 Drive Circuit
4 -25	Figure 4 -22	Block Diagram of BC-61/BC-62e Photo Drive Circuit
4 -32	Figure 4 -23	Purge Unit
4 -33	Figure 4 -24	Carriage
4 -35	Figure 4 -25	Paper Feed Motor Drive Switching
4 -36	Figure 4 -26	Auto Platen-Head Gap Adjustment
4 -37	Figure 4 -27	Paper Feed Mechanism
4 -38	Figure 4 -28	Paper Separator
4 -39	Figure 4 -29	Printer Electrical System
4 -40	Figure 4 -30	Logic Board Block Diagram
4 -43	Figure 4 -31	Printer Block Diagram
4 -44	Figure 4 -32	Motor Drive Circuit
4 -45	Figure 4 -33	AC Adaptor Output Voltages
4 -46	Figure 4 -34	Sensor Positions

#### *Part 5: MAINTENANCE*

5 - 3	Figure 5 - 1	Grease Points
5 - 4	Figure 5 - 2	Main Cover and Connector Cover
5 - 4	Figure 5 - 3	Releasing the Carriage Lock
5 - 5	Figure 5 - 4	Bearings at Ends of Support shaft
5 - 5	Figure 5 - 5	Purge Unit and Bottom Case Assembly
5 - 5	Figure 5 - 6	Tightening Idler Pulley Assembly Screw
5 - 6	Figure 5 - 7	Maintenance Jet and Waste Ink Absorbers
5 - 7	Figure 5 - 8	Tightening the Chassis Fixing Screws
5 - 8	Figure 5 - 9	Screws Influencing Head Gap
5 - 9	Figure 5 -10	Measuring Sheet Setting 1
5 - 9	Figure 5 -11	Measuring Sheet Setting 2

Page		
5 -10	Figure 5 -12	Thickness Gauge Setting
5 -10	Figure 5 -13	Check the Head Gap
5 -11	Figure 5 -14	Adjust the Head Gap 1
5 -12	Figure 5 -15	Adjust the Head Gap 2
5 -37	Figure 5 -16	Logic Board
5 -39	Figure 5 -17	Carriage Board
5 -44	Figure 5 -18	Logic Board (Face)
5 -44	Figure 5 -19	Component Board (Back)
5 -45	Figure 5 -20	Carriage Board (Face)
5 -45	Figure 5 -21	Carriage Board (Back)

## IV. TABLE INDEX

	<b><i>Part 2: PRODUCT SPECIFICATIONS</i></b>		
Page			
2 - 5	Table 2- 1	BJ Cartridge vs Print Mode	
2 -10	Table 2- 2	Paper Specifications	
2 -12	Table 2- 3	IO Signals Compatible Mode	
2 -13	Table 2- 4	IO Signals in Nibble Mode	
2 -13	Table 2- 5	IO Signals in ECP Mode	
	<b><i>Part 3: OPERATING INSTRUCTIONS</i></b>		
3 - 9	Table 3- 1	Printer Paper Settings	
3 -14	Table 3- 2	Operator Calls	
3 -15	Table 3- 3	Service Calls	
3 -21	Table 3- 4	Service Mode	
	<b><i>Part 4: TECHNICAL REFERENCE</i></b>		
4 - 8	Table 4- 1	Number of Passes vs Number of Operational Head Nozzles	
4 -10	Table 4- 2	Main Default Print Mode Settings	
4 -22	Table 4- 3	BJ Head Input and Output Signals	
4 -27	Table 4- 4	AND Gate Contacts and IDATA Order	
4 -27	Table 4- 5	Electrode Connection Pins	
4 -28	Table 4- 6	Index Connections	
4 -28	Table 4- 7	Index Sensor Signals and BJ Cartridge Detection	
4 -30	Table 4- 8	Cleaning Conditions and Ink Consumption (Average)	
4 -48	Table 4- 9	Ink-out Detection Timing	
	<b><i>Part 5: MAINTENANCE</i></b>		
5 -39	Table 5- 1	Contacts (DARK COL and LIGHT COL)	





# *Part 1*

## **SAFETY AND PRECAUTIONS**

Page	
1 - 1	1. SAFETY PRECAUTIONS
1 - 1	1.1 Moving Parts
1 - 2	1.2 Front Cover
1 - 3	1.3 Ink Stains
1 - 5	1.4 Live Parts
1 - 6	1.5 BJ Cartridge Metal Plate
1 - 7	2. MACHINE PRECAUTIONS
1 - 7	2.1 BJ Cartridge Handling
1 - 9	2.2 Ink Tank Handling
1 -10	2.3 Printer Handling
1 -12	3. NOTES ON SERVICING
1 -12	3.1 EEPROM Data
1 -13	3.2 Service Mode of Printer Driver
1 -13	3.3 Protecting the Power Supply
1 -14	3.4 Static Electricity
1 -15	3.5 Disassembly and Assembly
1 -15	3.6 Self-Diagnosis





# 1. SAFETY PRECAUTIONS

## 1.1 Moving Parts

Be careful not to let your fingers, hair, clothing, accessories, etc., become caught up in the moving parts of the printer.

There are moving parts associated with the carriage motor and paper feed motor.

### Carriage motor

Carriage belt, idler pulleys, and carriage

### Paper feed motor

Paper feed roller, pressure rollers, spurs, pick-up roller, slow down gear, paper output guide, and purge unit.

Be sure that the front cover is closed so that there is no risk of contacting the moving parts, except when checking operation during servicing.

Note that the spurs are made of metal with a sharp edge. Be careful not to touch the spurs with your bare hands.

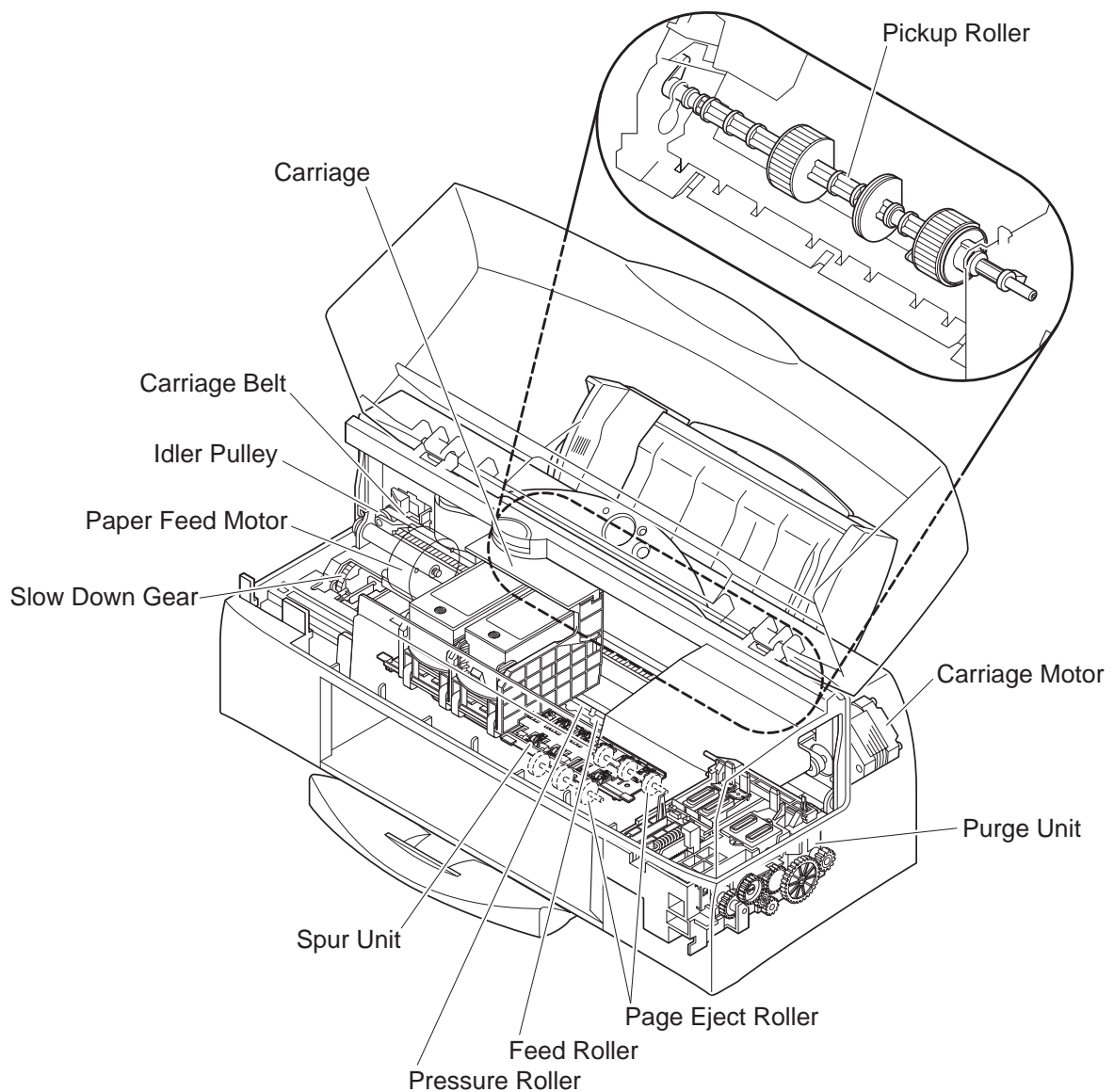
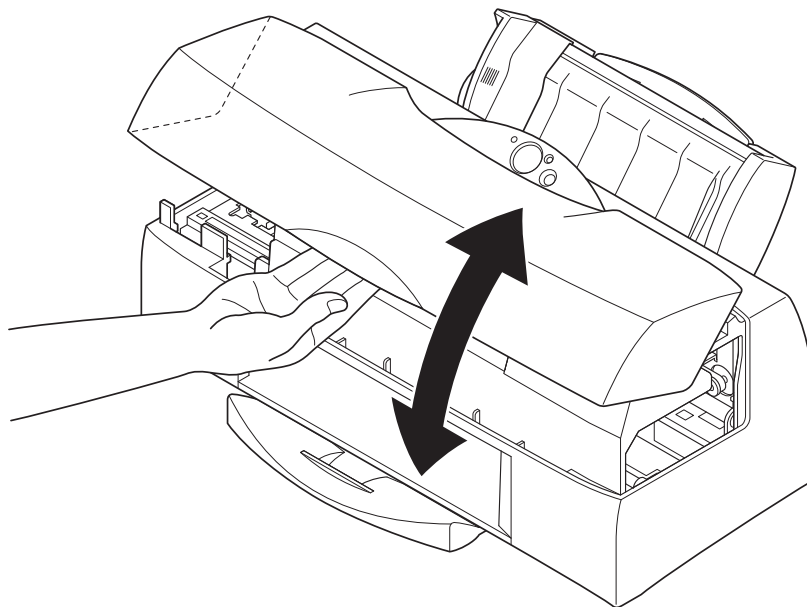

**Figure 1-1 The Printer's Moving Parts**

## 1.2 Front Cover

Hold the front part of the front cover to open and close the cover.

Be careful not to pinch your fingers between the front and main cover when closing the front cover.



**Figure 1-2 Front Cover**

**1.3 Ink Stains**  
**1.3.1 Ink path**

Be careful not to touch the ink path as it may stain your hands, clothes, printer, work table etc., during servicing.

The ink path consists of the BJ cartridge nozzles, head cap, waste ink tube, head wiper, cleaner unit, maintenance jet receiving section, and waste ink absorber.



**CAUTION**

Although the ink and ink optimizer for plain paper are not harmful to the human body, they contain organic solvents indicated on the package. Avoid getting the ink into your mouth and eyes, and store out of reach of children.

If ink does get into your eyes, wash with plenty of water and consult a doctor. If for some reason a large amount of ink is swallowed, consult a doctor immediately.

Give the doctor the information on the BJ cartridge package.

This ink contains dyes, that cannot be removed from clothing, etc.

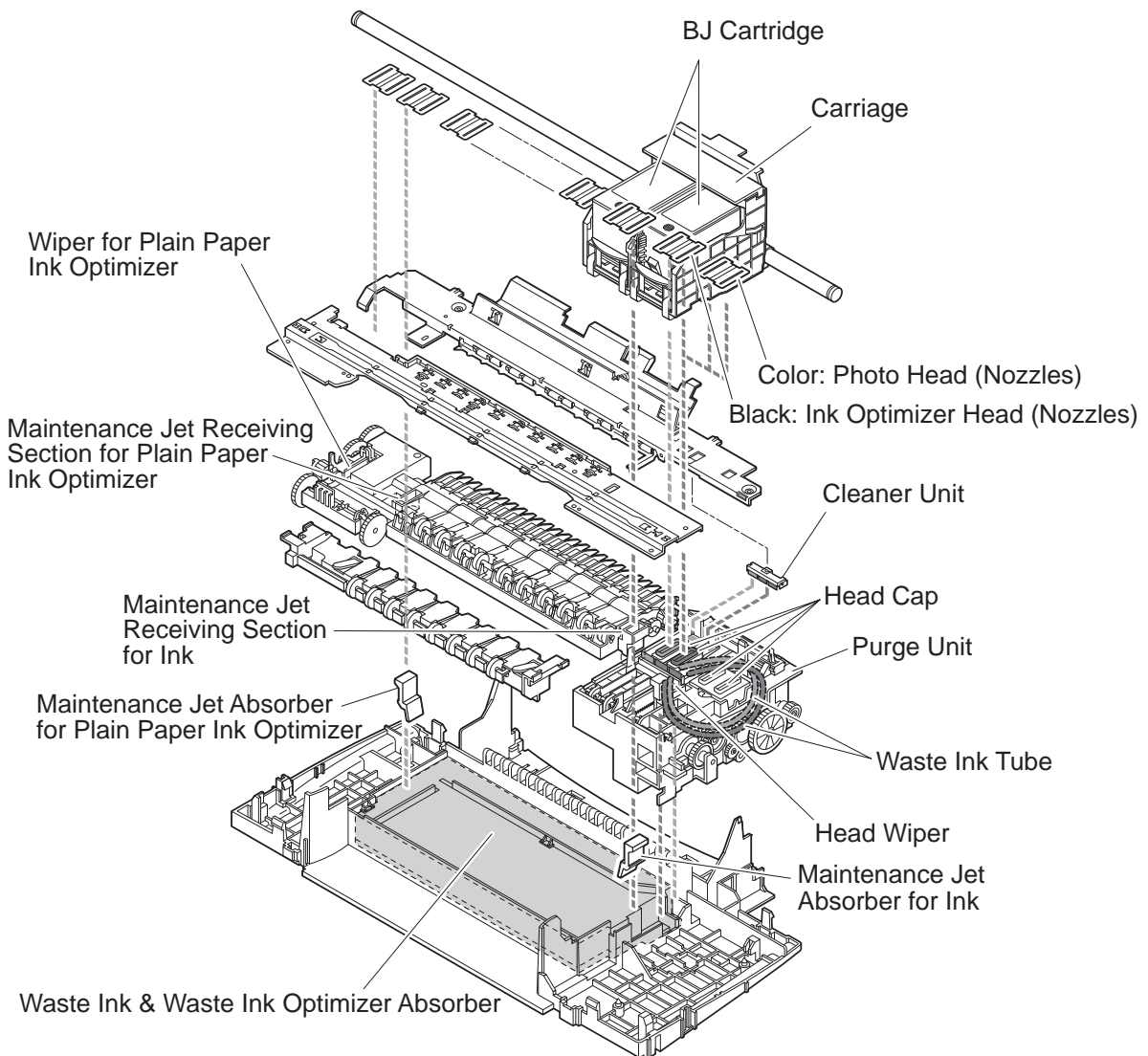

**Figure 1-3 Ink Path**

The joints and ink outlets of the respective ink tanks of the photo BJ cartridge [BC-62e Photo] and color BJ cartridge [BC-61] are also part of the ink path and must be handled with care.

Unless absolutely necessary, do not remove the ink tanks from a BJ cartridge, since air may enter the ink path and have a negative effect on print quality.

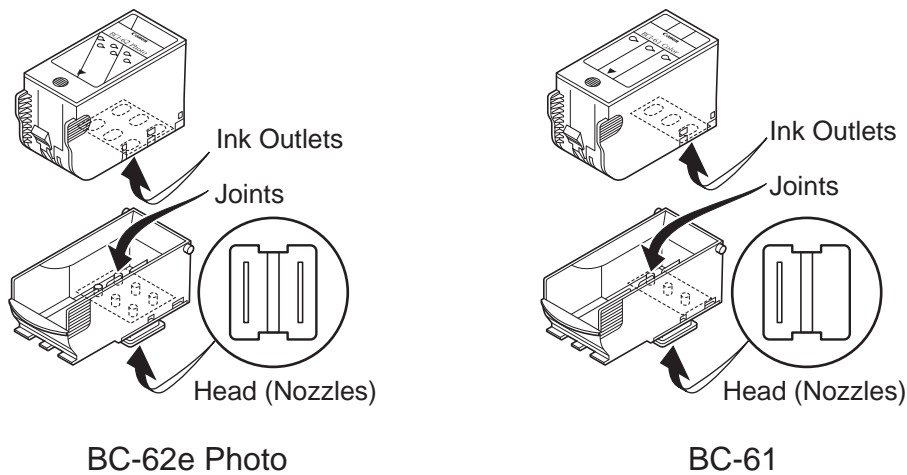

**Figure 1-4 BC-62e Photo and BC-61**



The BJC-7100 uses a variety of inks and an ink optimizer for printing on plain paper. The ink optimizer is an almost colorless, transparent fluid. We will refer to the ink optimizer for plain paper simply as ink optimizer or just optimizer for simplicity purposes. We will also refer to the various colored inks and the ink optimizer for plain paper simply as "inks".

### 1.3.2 Ink mist

The BJ cartridge ejects ink onto the paper. After prolonged or heavy-duty use of the printer, a small amount of ink mist splattered during printing can dirty the printer such as the platen.

Turn off the power, open the front cover, and clean the dirty parts with a soft moist cloth. This is to prevent dirtying the paper, your hands, and clothing from touching these parts.

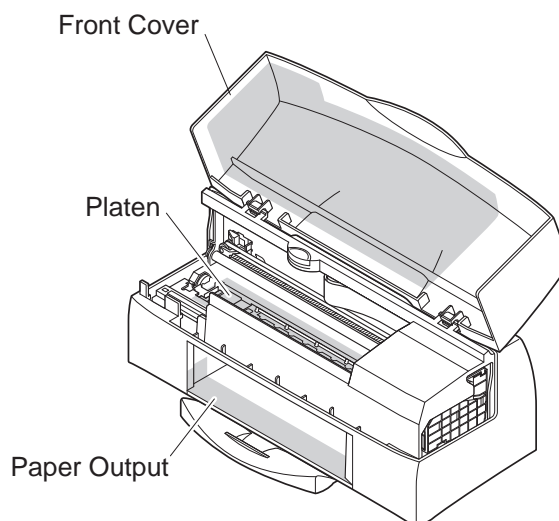

**Figure 1-5 Ink Mist**

### 1.4 Live Parts

When the plug of the printer's AC adapter is plugged into a live power outlet, the power supply unit of the printer is live regardless of the power being set to ON or OFF using the *POWER* button.

Be careful not to get on electric shock if you are checking the printer operation with the covers off.



## CAUTION

Do not attempt to dismantle the AC adapter. The mains AC voltage is supplied to the primary side of the AC adapter. To prevent risk of electric shock, do not attempt to dismantle the AC adapter to check its operation, etc.

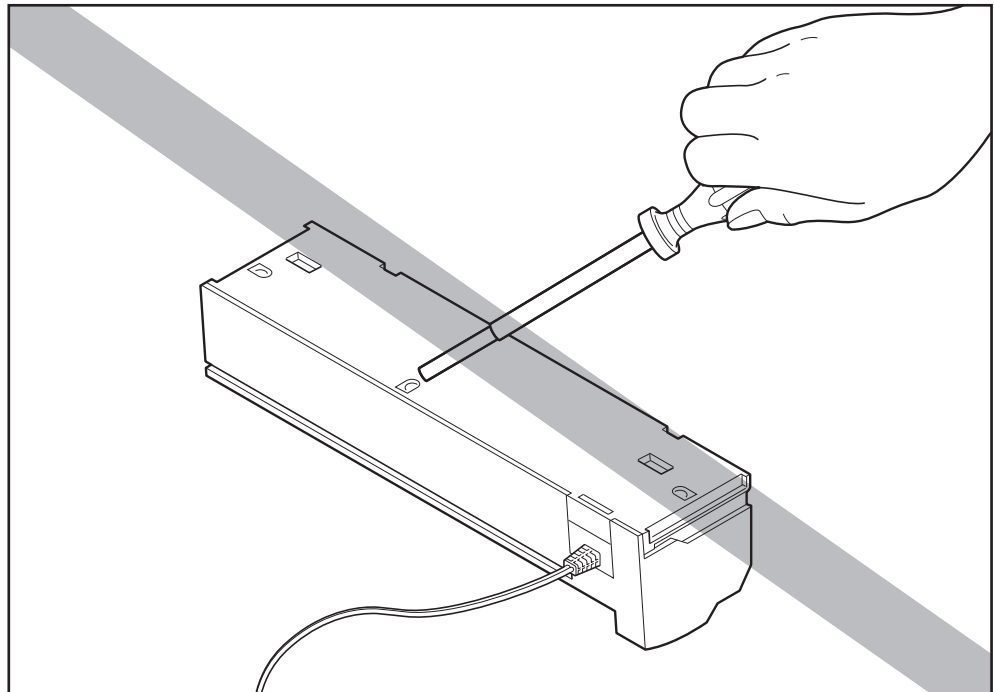

**Figure 1-6 AC Adapter**



If faulty, the AC adapter must be replaced as one unit (service part). The structural components, including the case, are not available individually as service parts. Do not attempt to dismantle the AC adapter.

### 1.5 BJ Cartridge Metal Plate

Do not touch the BJ cartridge's metal plate as it may be very hot. The metal plate heats up during printing and becomes particularly hot during heavy duty printing.



## CAUTION

Danger! High Temperature!  
Do not touch.

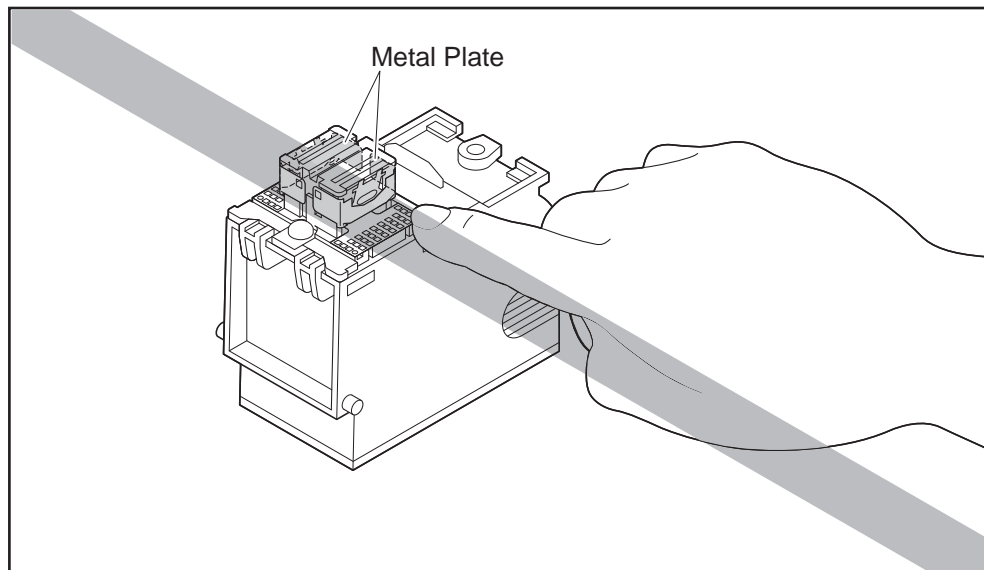

**Figure 1-7 BJ Cartridge Metal Plate**



The printer has the following protective mechanisms to detect overheating:

#### 1. Overheat detection when replacing cartridge

If overheating is detected, a beeper sounds four times and the carriage does not return to the replacement position. This is to prevent the user from touching the BJ cartridge's metal plate.

Resume the cartridge replacement after leaving the cartridge to cool for several minutes.

#### 2. Overheat detection during normal printing

The carriage movement and the paper eject operation are continued while the printing is stopped. Depending on the outcome of the ink-out detection after completion of printing a page, a beeper sounds to indicate the status of the error.

Ink available: BJ cartridge overheat error (beeper sounds 7 times)

Ink out: Ink-out error (beeper sounds 3 or 4 times)

When a BJ cartridge overheat error occurs, leave the cartridge to cool for several minutes then press the *RESUME* button.

These protective mechanisms are based on the temperatures detected by the sensors in the BJ head.



If the protective mechanism is activated and normal operation cannot be resumed after cooling the head for several minutes, see "Part 5: 6.

*TROUBLESHOOTING*" (page 5-13).

For details of ink-out detection, see "Part 4: 5.2.3 Ink-out detection" (page 4-48).

## 2. MACHINE PRECAUTIONS

### 2.1 BJ Cartridge Handling

#### 2.1.1 Unpacking the BJ cartridge

Do not unpack the BJ cartridge until you are ready to use it.

Before installing the BJ cartridge in the printer, remove the cap protecting the nozzles and gently peel off the protective tape.

Do not attempt to reuse the cap or the tape after they have been removed, as doing so may cause faulty printing.

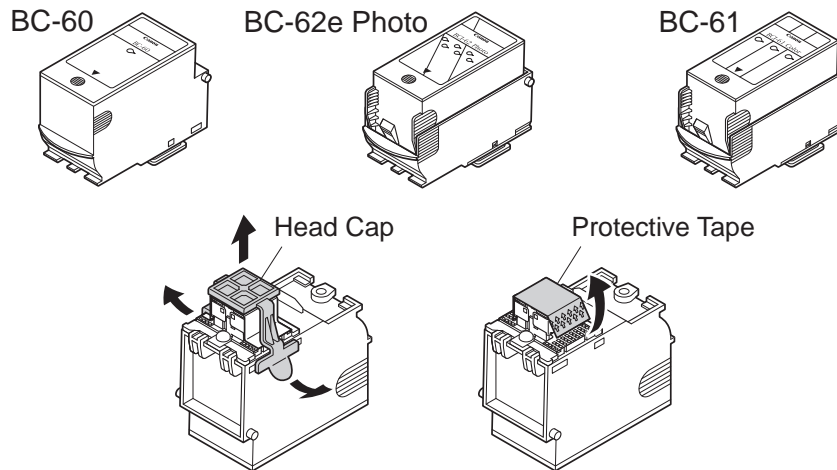

**Figure 1-8 Removing the BJ Cartridge Cap and Tape**



If you replace the cap on the color BJ cartridge or photo BJ cartridge, the sponge in the cap may cause the colors to bleed into each other. The nozzles may also become clogged.



Always move the carriage to the BJ cartridge replacement position before attempting to remove or install a cartridge. Failure to do so may result in damage to the BJ cartridge.

#### 2.1.2 BJ cartridge protection

To prevent the nozzles from clogging, never touch or wipe the nozzles, joint pipes, or ink tank outlets with your bare hands or with tissue paper, etc. After removing the cap and peeling off the protective tape from a BJ cartridge, promptly install the cartridge in the printer or store it in the cartridge holder. If the BJ cartridge is not capped or stored in the cartridge holder, the nozzles may clog due to dried out ink or dust, etc.

Do not attempt to leave color BJ cartridges or photo BJ cartridges with their ink tanks removed.

BJ cartridges cannot be disassembled, reassembled, or washed.



Clogged nozzles cause faulty printing. If this problem persists even after the nozzles are cleaned, replace the BJ cartridge.



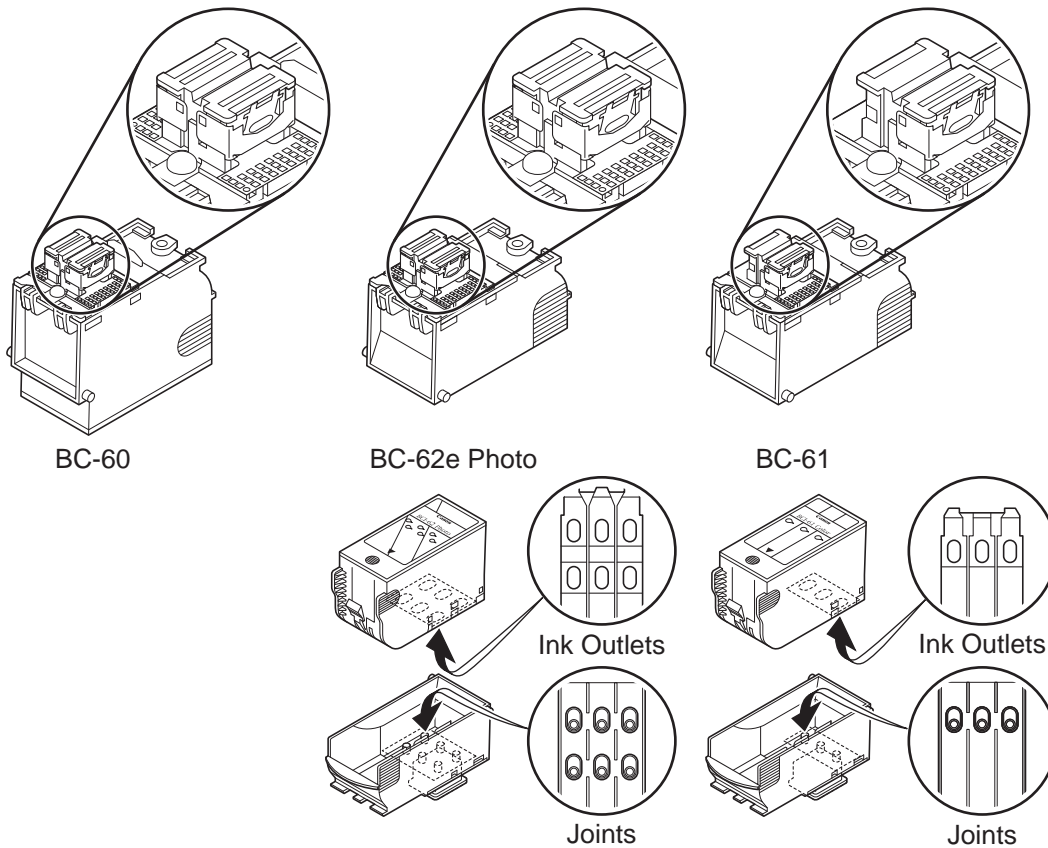

**Figure 1-9 BJ Cartridges**

### 2.1.3 Power on/off

When the printer is turned off with the *POWER* button, the printer automatically caps the BJ cartridge's nozzles for protection and to prevent ink leakage.

If the AC adapter is unplugged before the printer is turned off with the *POWER* button, the nozzles may not be capped. In this case, plug the AC adapter again, start up the printer and turn off the printer with the *POWER* button before unplugging the power cord. Note that, if you unplug the power during the recovery operation and then leave the printer, the purge unit may be damaged.



If the nozzles are not capped, the ink might dry out and clog the nozzles or leak from the cartridge.

### 2.1.4 When not using the printer

Keep the BC-60 BJ cartridge installed in the printer even when the printer is not in use. The BC-62e Photo and BC-61 BJ cartridges can be left installed in the printer or stored in the cartridge holder. This also applies when carrying, transporting, or storing the printer.



If the BJ cartridge is taken out of the printer, dried ink or dust may clog the nozzles, resulting in inconsistent printing.  
If the printer is moved or transported with no cartridge installed, ink may leak from the cap mechanism.



### 2.1.5 Ink electroconductivity

The ink used in the BJ cartridge can conduct electricity. If any ink leaks into the printer's mechanical parts, use paper towels, etc., to wipe clean. If the ink leaks onto the printer's electrical components, use tissue paper, etc., to wipe clean. If the ink gets to the IC chips on the PCB, or if it is too difficult to thoroughly clean off the ink, replace the respective parts.



---

Never connect the printer's power cord if ink has leaked inside the printer. It may damage the circuitry.

---

## 2.2 Ink Tank Handling

### 2.2.1 Unpacking the ink tank

Do not unpack the ink tank until you are ready to use it.

Before installing it in the color BJ cartridge, remove the cap covering the ink outlets.

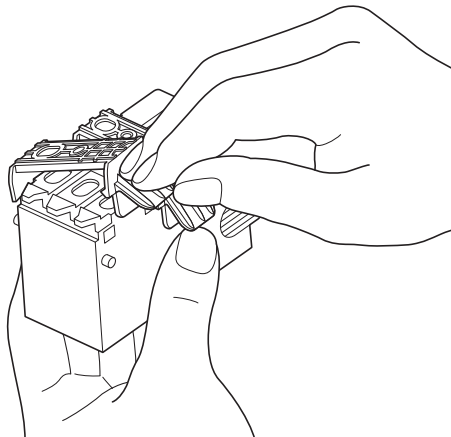
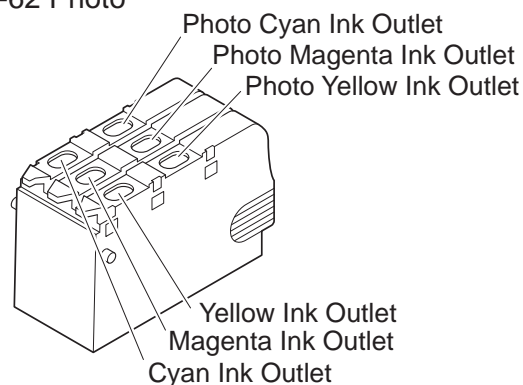

**Figure 1-10 Removing the Ink Tank Cap**

### 2.2.2 Preventing clogging

To prevent poor ink suction due to clogging of the joints in the BJ cartridge, never touch the ink tank's ink outlets. After removing the cap from the ink tank, promptly install the ink tank in the BJ cartridge to prevent the nozzles from clogging due to dried-out ink, dust, etc. Do not remove an ink tank from a BJ cartridge unless you are replacing it.

BCI-62 Photo



BCI-61 Color

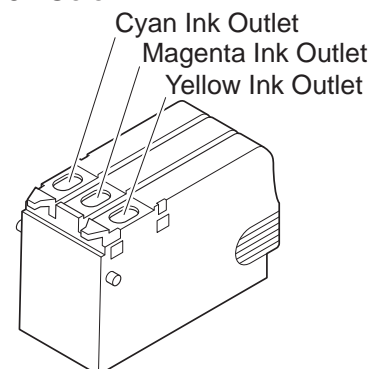

**Figure 1-11 The Ink Outlets on Ink Tank**

## 2.3 Printer Handling

### 2.3.1 Spurs

Take care not to bend the tips of the spurs.

The spurs that transport and eject the paper after printing are very small and can easily be deformed.

If a spur is deformed, its contacting surface with the printed paper increases, creating a dotted line.

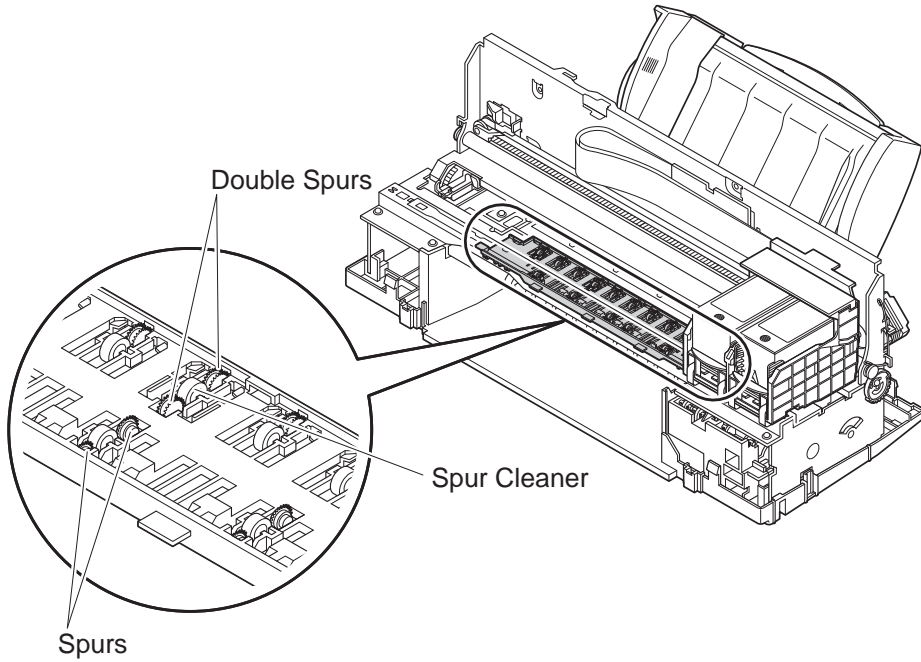

Figure 1-12 Spurs

### 2.3.2 Damage due to static electricity

The static charge accumulated by your body from clothing can damage electrical components and alter their electrical characteristics.

Never touch the carriage contacts or BJ cartridge contacts.

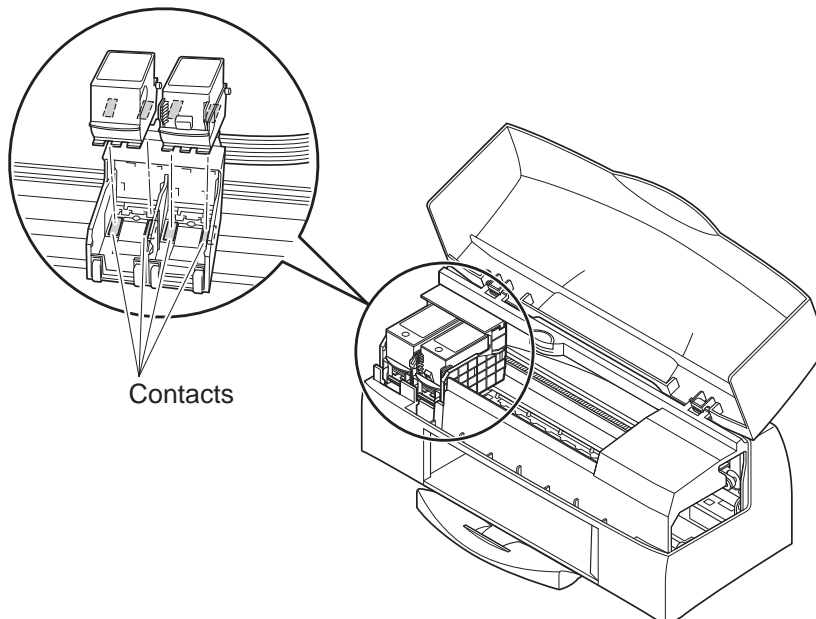

Figure 1-13 Contacts

### 2.3.3 Ink leakage and dry-out

Make sure a BJ cartridge is installed before turning off the power, using the *POWER* button.

When you turn off the printer using the *POWER* button, the printer automatically performs the following operations:

#### Cleaning

Any ink left in the purge unit or in the nozzles of the BJ cartridge is removed.

#### Capping

To prevent ink dry-out, the BJ cartridge's nozzles are capped automatically and the carriage is locked in position.

If you unplug the AC adapter by mistake, plug the power cord again, turn the power on and then off again using the *POWER* button, then unplug the AC adapter.

If you turn the power off or unplug the AC adapter when the BJ cartridge has been removed, the nozzles will not be automatically capped or the carriage locked in position, and hence there is a risk of ink leaking or dry-out.

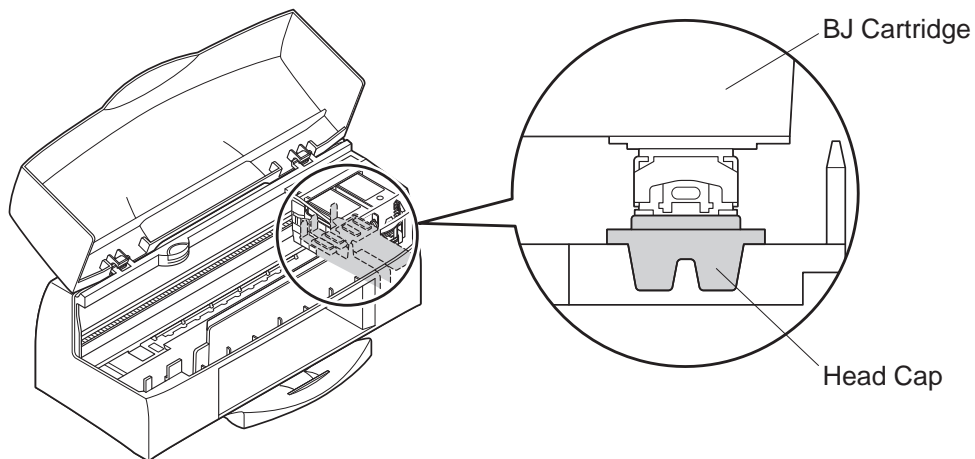

**Figure 1-14 Capping Position**



If the power cannot be turned on due to some failure, manually move the carriage belt or the carriage itself to the capping position. For details, see "Part 3: 2.2 Manual Capping" (page 3-13).

### 2.3.4 Carrying the printer

Hold both sides of the bottom of the printer to carry it. Note that inserting your hand into the paper outlet may dislodge or damage the paper guides.

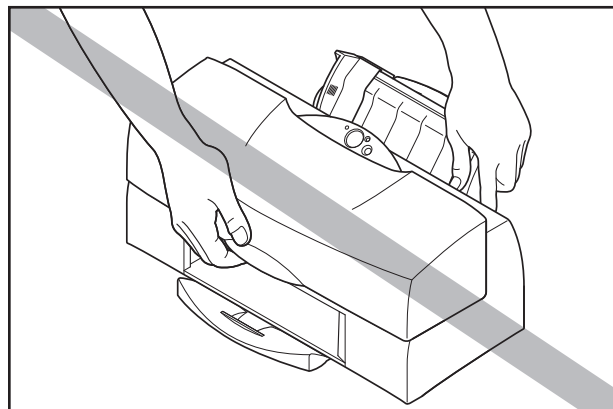

**Figure 1-15 Carrying the Printer**

## 3. NOTES ON SERVICING

### 3.1 EEPROM Data

The printer stores the function settings and keeps track of various information including the total sheets printed, the number of cartridge replacements, the total waste ink amount, and the head position adjustment values. The data is stored in the EEPROM on the logic board.

Note the following precautions during servicing:

#### 1) Before servicing

You can check the EEPROM data with a test print. The total sheets printed can give you an idea of how much the printer has been used.

#### 2) During logic board replacement

Always replace the waste ink absorber when replacing the EEPROM.

If you do not replace the waste ink absorber, the data on waste ink amount will differ from the amount of ink that can be absorbed by the waste ink absorber. There is therefore a risk of ink leaking.

When replacing the logic board, be sure to reset all the data. Because the data on new EEPROMs is undefined, they cannot be used until they are reset. For details of handling EEPROMs, see "Part 3: 3.4 EEPROM" (page 3-19).

#### 3) After waste ink absorber replacement

After replacing full waste ink absorbers, reset the EEPROM's waste ink counter.

#### 4) If you accidentally reset the EEPROM's waste ink amount data or all data

Once reset, the EEPROM data cannot be restored. If you accidentally reset the EEPROM, you must take the same steps as when replacing the logic board.



After the EEPROM is reset, the data it contained cannot be printed out with a test print. If you want to check the stored data, be sure to make a test print before resetting the EEPROM.

Note that you cannot reenter the data from the printer's control panel or by using a computer.

If the EEPROM is faulty, or all data is reset, all data is lost. Whenever possible, restore all data such as the head alignment to the user's settings.



During operation, the waste ink amount (EEPROM data) is automatically updated. An error message is displayed and operation halted when the waste ink absorber is nearly full. If this occurs, refer to "Part 5: 6. TROUBLESHOOTING" (page 5-13).

See "Part 3: 3.8.3 Printing EEPROM data" (page 3-23) for how to make a test print of the stored data.

You can choose to either reset the waste ink counter or all data. See "Part 3: 3.8.2 Resetting EEPROM data" (page 3-22) for details.

### 3.2 Service Mode of Printer Driver

There are certain printer driver control functions, described below, that are, in principle, hidden from the end user. These service mode functions, which must be used with caution, are provided for service purposes only.

See "Part 3: 3.3.2 Service mode of printer driver" (page 3-18) for details.

### 3.3 Protecting the Power Supply

The power supply for the BJC-7100 printer consists of an AC adapter and a power supply circuit on the logic board. Provided the AC supply is connected, the printer power supply is live whether or not the power is set ON or OFF using the *POWER* button.

Always unplug the AC adapter from the power outlet before connecting it to or disconnecting it from the printer. Ignoring this warning can result in damage and failure of the printer power supply.

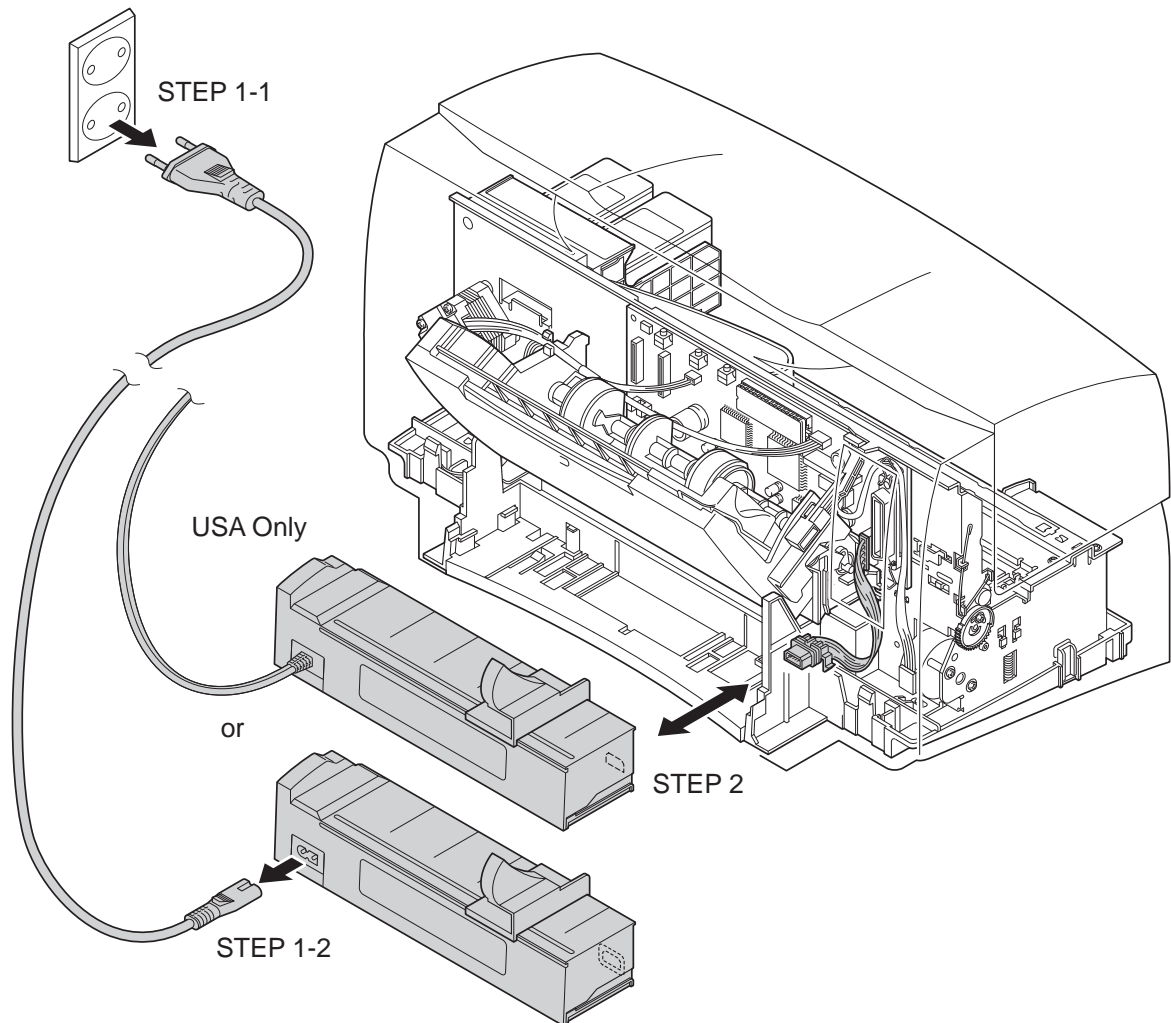

**Figure 1-16 Protecting the Power Supply**



When moving the carriage by hand when, for example, manually capping the ink nozzles or releasing the carriage lock, do so slowly while paying attention to the operation of the carriage motor; the back electromotive force generated by moving the carriage horizontally may damage the motor control board. If it is necessary to move the carriage horizontally fairly frequently, such as when replacing or adjusting the carriage, temporarily disconnect the carriage motor connector from the control board.

### 3.4 Static Electricity

The electrostatic charge accumulated in clothing can damage electrical components and alter their electrical characteristics.

Before disassembling the printer to service it, use a wriststrap or other grounded metal object to discharge the static electricity. The following parts must not be touched before you have discharged the static electricity from your body:

- Logic board, carriage board
- Motor control board
- Cable connectors and contacts
- BJ cartridge signal contacts

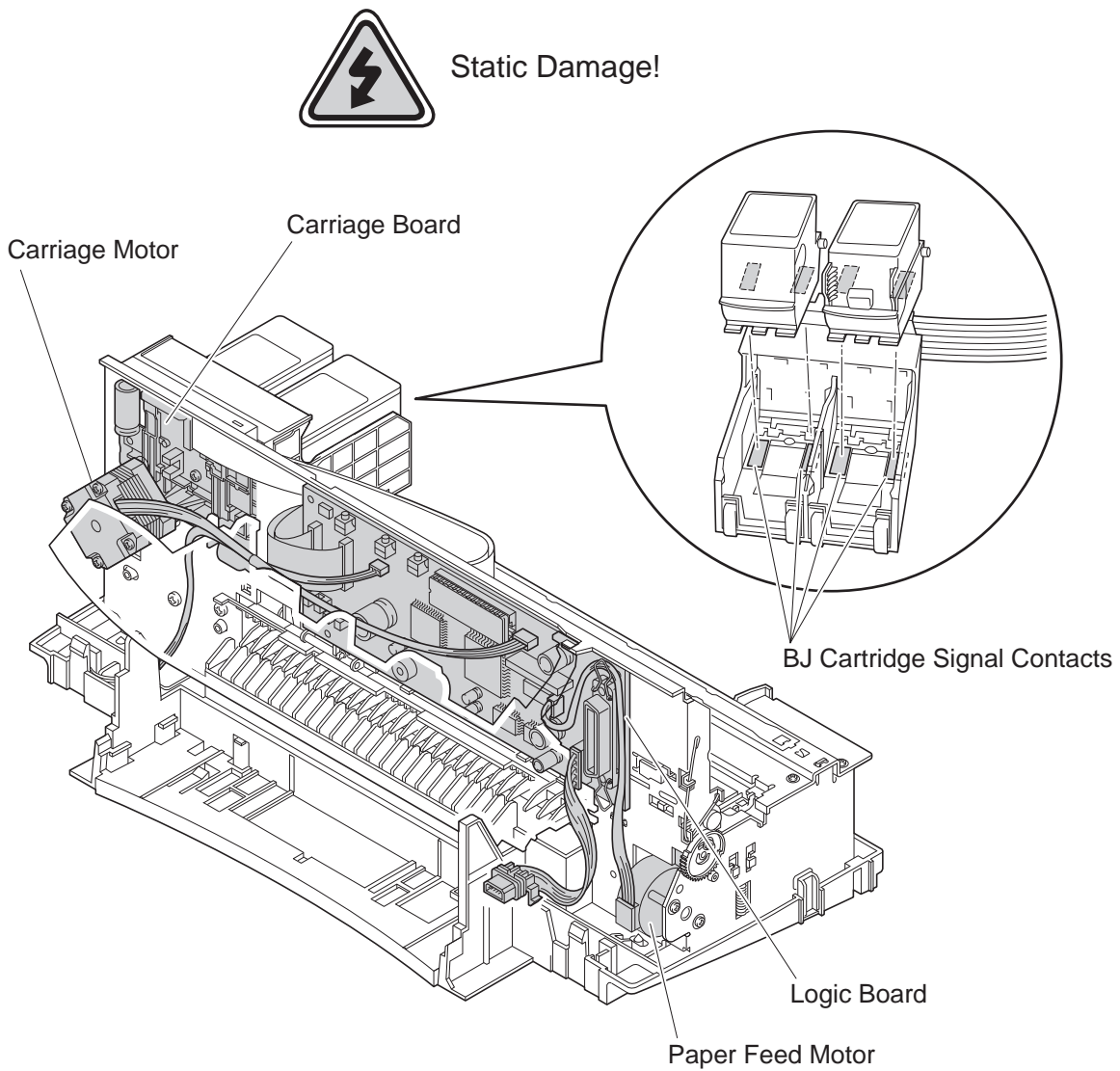

**Figure 1-17 Electrical System of Printer**



### 3.5 Disassembly and Assembly

#### 3.5.1 Parts that cannot be disassembled

Do not disassemble the ribbon cable to the head on the carriage unit. The position in relation to the contacts with the BJ cartridge is factory adjusted, and cannot be readjusted during printer servicing.

In addition, do not attempt to disassemble the AC adapter, BJ cartridge, or ink tanks.

In principle, do not loosen any of the screws painted red in the printer mechanism (except when adjusting the head gap using the jig). The red screws hold the adjustable plate that determines the gap between the nozzles of the BJ cartridge and the platen.

This gap is adjusted to the optimal value when the printer leaves the factory.

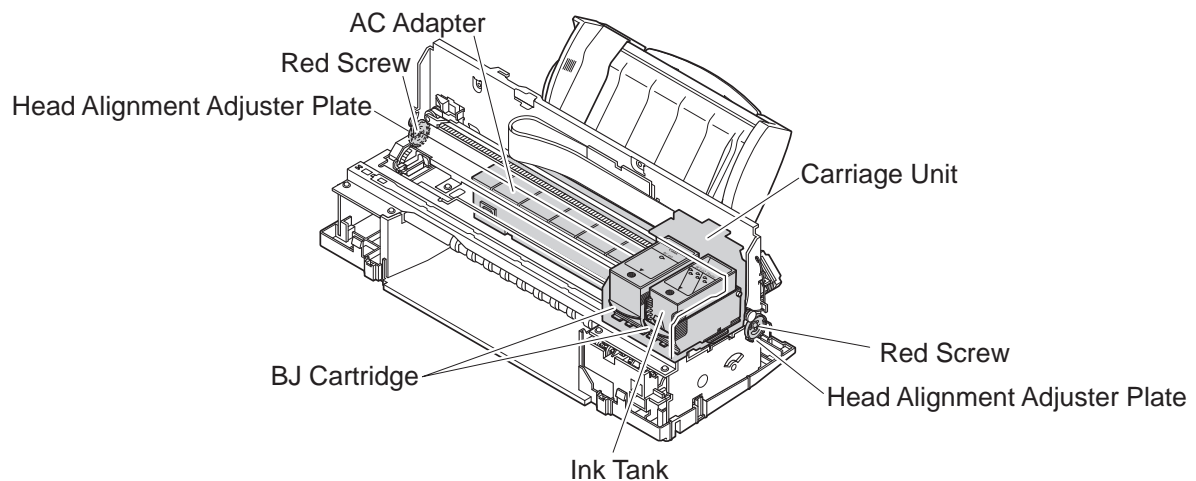

**Figure 1-18 Parts that Cannot be Disassembled**



In addition to the above, do not attempt to disassemble any parts not shown disassembled in the exploded diagrams in the parts catalog. Failure to observe this warning may result in those parts not functioning as originally intended after they are reassembled.

#### 3.5.2 Parts requiring careful attention during disassembly and assembly

The printer has many parts that can be damaged during disassembly and assembly. For details, see "*Part 5: 4. DISASSEMBLY AND REASSEMBLY*" (page 5-4). Please read this section carefully before attempting to disassemble and assemble the printer.

The printer also has many plastic parts. When disassembling the printer, take care not to break or bend the plastic hooks.



Some plastic parts contain glass fibers for extra rigidity and precision, but since their viscosity is low, the plastic hooks can break easily when excessive force is used. Do not pull a plastic hook with excessive force while unhooking it.

### 3.6 Self-Diagnosis

The printer has a self-diagnosis feature to detect hardware defects. The results of the self-diagnosis are indicated on the LED on the control panel, and by the beeper. For details, see "*Part 3: 3.1 Error Indications*" (page 3-14).

This page intentionally left blank





# *Part 2*

# PRODUCT SPECIFICATIONS

Page	
2 - 1	1. PRODUCT OUTLINE
2 - 1	1.1 Outline
2 - 2	1.2 Features
2 - 3	1.3 BJ Cartridge
2 - 6	1.4 SB-60 BJ Cartridge Container
2 - 6	1.5 Consumables
2 - 7	2. SPECIFICATIONS
2 - 7	2.1 General Specifications
2 -10	2.2 Paper Specifications
2 -12	2.3 Interface Specifications



# 1. PRODUCT OUTLINE

## 1.1 Outline

The BJC-7100 is a personal desktop color bubble-jet printer that uses a new 600dpi BJ cartridge and technology to achieve outstanding print quality and photographic realism. The printing process uses an ink optimizer to enable water resistance printing on plain paper.

The BJC-7100 printer uses new accurate photo BJ cartridge BC-62e Photo and new paper eject mechanism to achieve high speed printing with high quality print.

The BJC-7100 printer, which is easy to operate under Microsoft Windows, and is compatible with the Internet and multimedia tools such as digital cameras, is targeted at a wide range of users in the small-office and personal-computer environments who require high-quality full color printing.

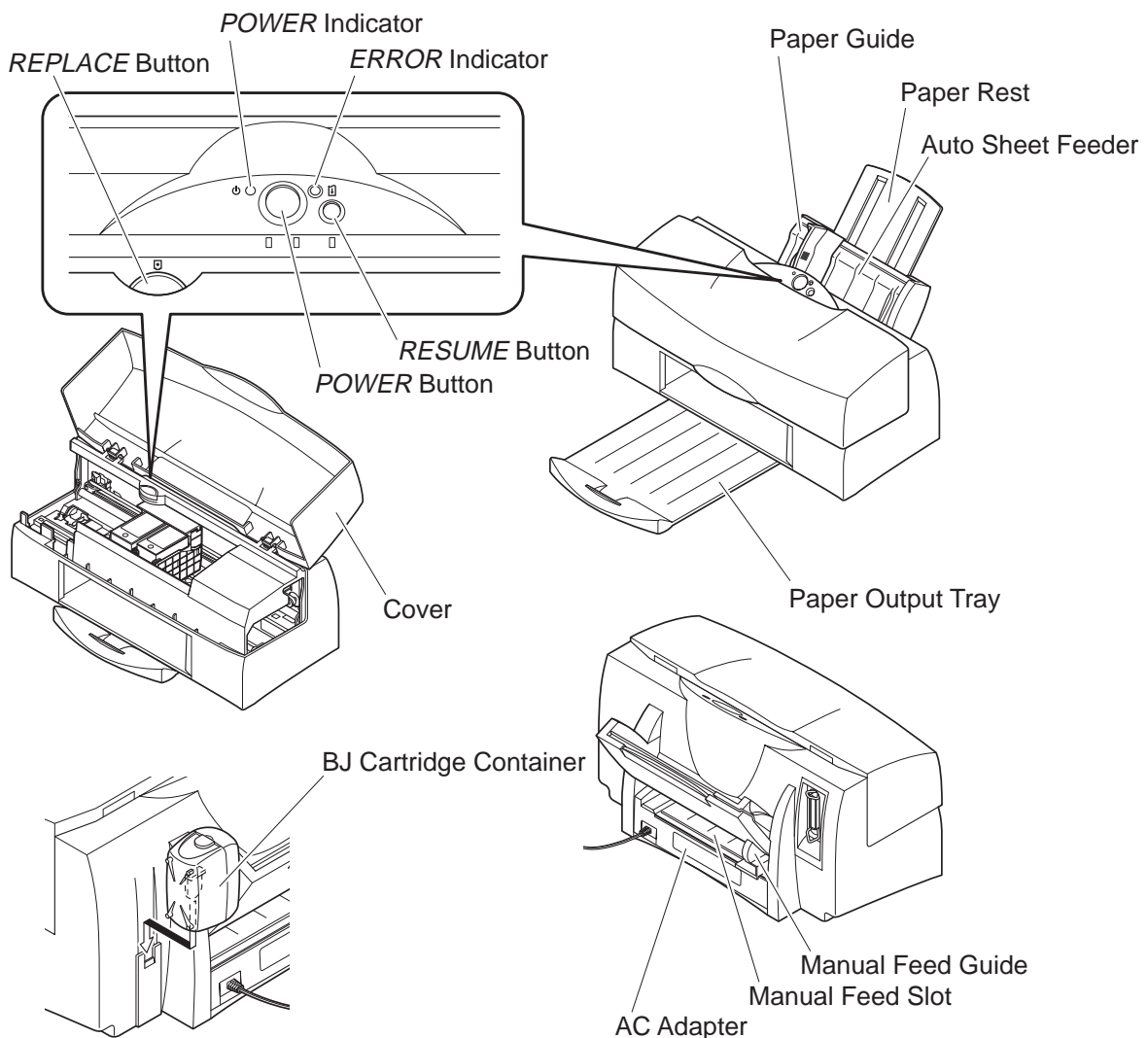

Figure 2-1 Printer Appearance



The ink optimizer is an almost colorless, transparent fluid. For simplicity in this manual, we refer to the ink optimizer for plain paper simply as ink optimizer or just optimizer. We also refer to the various colored inks and the ink optimizer for plain paper simply as "inks".

## 1.2 Features

1. The new 600dpi BJ cartridge provides high-resolution printing at up to 1200 (H) × 600 (V) dpi when using the exclusive printer driver.  
There are three types of new BJ cartridge: BC-60, BC-62e Photo, and BC-61. (Note that the BJ cartridge configuration differs according to the country.)
2. The printer is equipped with two BJ cartridges.  
The BC-60 is normally installed in the printer and either the BC-62e Photo or BC-61 is installed as required for the type of printing to be carried out.
3. The print process uses an ink optimizer to enable maximum water resistance when printing on plain paper (and envelopes).  
In this new printing process, the surface of the paper is coated with the ink optimizer prior to being printed. The ink optimizer is discharged from the special BJ head of the BC-60.
4. The straight manual insertion path allows printing on a wide variety of papers.  
In addition, the automatic platen-head adjustment mechanism obviates the need for levers for selecting papers and platen-head gap.
5. The printer performs high speed print; HQ: 5.8ppm, HS: 7.6ppm (BK; PC magazine)
6. The printer is equipped with an ink-out detection function based on the conduction of static electricity.  
An electrical signal is input to the ink path in the BJ cartridge. This signal is picked up by the electrode on the carriage, and the signal level is used to determine the existence or absence of ink.
7. The printer is equipped with an IEEE1284-compatible bidirectional parallel interface.  
This interface is compatible with nibble mode and ECP mode.
8. The built-in control mode is the Canon extended mode.  
The host computer sends print signals in Canon extended mode, generated by the special printer driver.
9. The printer is supplied with Windows 3.1, Windows 95 and Windows 98 special printer driver.
10. The printer is powered by an AC adaptor, installed by manufacturing.



---

The ink optimizer printing process can be used in both monochrome and color printing when the printer driver is set to plain paper (including postcards and envelopes) in all but Draft mode. It cannot be used if the driver is set to other than plain paper (special papers and film, etc.).

---



---

The ink-out detection mechanism confirms that the BJ cartridge is out of ink. The mechanism does not measure the amount of ink remaining in the cartridge and therefore does not necessarily indicate an error at the point where print quality deteriorates as the ink runs out.

---

## 1.3 BJ Cartridge

### 1.3.1 Black BJ cartridge (BC-60)

The BC-60 BJ cartridge is used for monochrome printing and for printing using the ink optimizer. It is a head and ink tank integrated type, disposable BJ cartridge consisting of a unified BJ head and ink tanks for black ink and ink optimizer. There are two parallel BJ heads, each with 304 nozzles. One head supplies ink while the other supplies the ink optimizer.

Replace the BJ cartridge if either the black ink or ink optimizer runs out, or if satisfactory printing cannot be achieved even after the stipulated cleaning operations have been performed. Also replace the cartridge if more than 12 months has elapsed after the seal is broken.

The BC-60 BJ cartridge will print approximately 870 pages of a standard 1500-character print pattern (Default setting of Text mode).

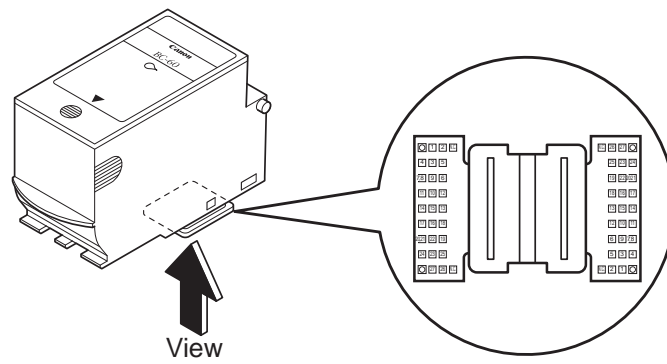

**Figure 2-2 Black BJ Cartridge (BC-60)**

### 1.3.2 Photo BJ cartridge (BC-62e Photo)

The BJ head for the BC-62e Photo has been modified to considerably improve the ink jet emission precision.

The BC-62e Photo BJ cartridge is used for photo-realism (super photo mode) (when printing photographs with substantial numbers of half-tones and light colors). The cartridge consists of a main unit that separates the BJ heads, and disposable ink tanks (BCI-62 photo).

There are two parallel BJ heads, each with 240 nozzles. One head supplies color inks while the other supplies photo inks. Both BJ heads have three vertical rows of 80 nozzles each for yellow, magenta, and cyan.

The total 6 ink tanks for color and photo inks are integrated.

The BC-62e Photo BJ cartridge works by layering the photo inks, which are about 1/3rd the density of the color inks, thereby enabling pale colors and halftones to be printed. The color inks are used to print denser colors and fill larger areas with one color.

Replace the ink tanks if any of the 6 inks runs out, or if satisfactory printing cannot be achieved even after the stipulated cleaning operations have been performed. If you still cannot obtain satisfactory print quality, replace the BJ cartridge. Also replace the cartridge if more than 12 months has elapsed after the seal is broken. (Replace the ink tank 6 months after the seal is broken.)

The BC-62e Photo BJ cartridge will print approximately 90 pages per tank of a standard photo print pattern (Reference data).

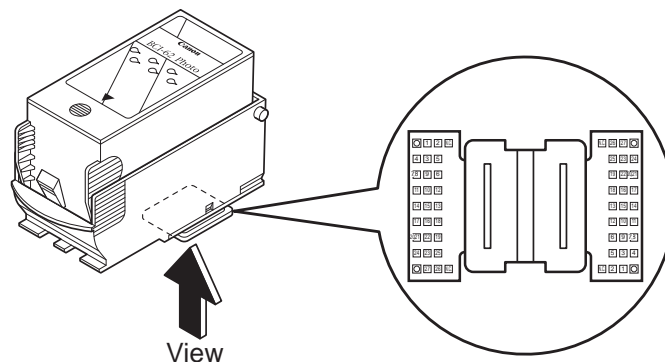

Figure 2-3 Photo BJ Cartridge (BC-62e Photo)

### 1.3.3 Color BJ cartridge (BC-61)

The BC-61 BJ cartridge is used for color printing (denser colors and filling larger areas with color). The cartridge consists of a main unit that separates the BJ heads, and disposable ink tanks (BCI-61 Color).

The BJ head has 240 nozzles supplying the color inks. There are three vertical rows of 80 nozzles each for yellow, magenta, and cyan. The 3 ink tanks are integrated. Replace the ink tanks if any of the 3 inks runs out, or if satisfactory printing cannot be achieved even after the stipulated cleaning operations have been performed. If you still cannot obtain satisfactory print quality, replace the BJ cartridge. Also replace the cartridge if more than 12 months has elapsed after the seal is broken. (Replace the ink tank 6 months after the seal is broken.) The BC-61 BJ cartridge will print approximately 275 pages per tank of a standard color print pattern.

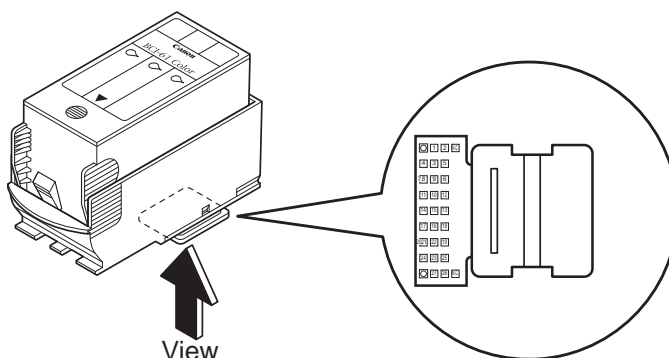

Figure 2-4 Color BJ Cartridge (BC-61)

### 1.3.4 BJ cartridge vs print mode

The inks are used in different ways according to the selected print mode, as shown in the table below.

TABLE 2-1 BJ CARTRIDGE VS PRINT MODE

Print Mode	BC-60		BC-62e Photo		BC-61
	Black Ink	Ink Optimizer	Color Ink	Photo Ink	Color Ink
Fast	○	✕	○	✕	○
Standard (Fast)	○	△	○	✕	○
Standard (High Quality)	○	△	○	✕	○
High Quality	○	△	○	○	○
Fine	○	△	○	○	○

○: Used    △: Used only for plain paper, envelopes    ✕: Not used

When you use the BC-62e Photo BJ cartridge to print in color using only the normal color inks and not the photo inks, the normal color inks will run out and the ink tanks will have to be replaced before the photo inks are used up.



The estimated print quantity for the BC-60 (approximately 870 pages in monochrome) is for printing only in monochrome and assumes that the ink optimizer is not used up by color printing. If the ink optimizer is used in color printing, the cartridge may not print as many pages and it may be necessary to replace the BC-60 even if you do not print in monochrome at all.



When handling BJ cartridges and ink tanks, observe the notes in "Part 1: 2.1 BJ Cartridge Handling" (page 1-7).

## 1.4 SB-60 BJ Cartridge Container

The SB-60 cartridge container is for storing the BC-62e Photo or BC-61 BJ cartridge—whichever is not currently being used.

The SB-60 cartridge container is supplied with the printer, and can also be bought as optional equipment.

After placing a cartridge in the holder, be sure to close the lid securely. Failure to do so may result in the nozzles clogging due to dried ink.

The SB-60 cartridge container can be used to store either the BC-62e Photo or BC-61 BJ cartridge. Store either of the cartridges in the holder if you have removed the protective caps and tape.

The cartridge container can be installed on the printer.

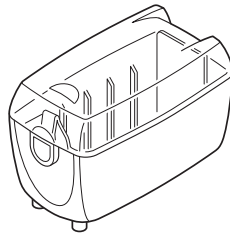

**Figure 2-5 BJ Cartridge (SB-60)**



Note that the BC-60 cartridge cannot be stored in the SB-60 cartridge container, and is always installed in the printer.

## 1.5 Consumables

### 1.5.1 BJ cartridge

The BJ cartridges (BC-60, BC-62e Photo, and BC-61) used in the BJC-7100 printer are supplied as consumables. Except for the packaging, these consumables are identical to the BJ cartridges supplied with the new printer.

The BC-62 Photo used in the BJC-700J Printer cannot be used on this printer. If the BC-62 Photo is installed on BJC-7100, printing is carried out, however, print quality may deteriorate drastically.

### 1.5.2 Ink tank

The BCI-62 Photo ink tank for the BC-62e Photo cartridge, and the BCI-61 Color ink tank for the BC-61 cartridge are both supplied as consumables.

Always replace the ink tanks if one of the colors runs out, or satisfactory print quality cannot be achieved even after the stipulated cleaning operations. If, after replacing the ink tanks, you still cannot obtain satisfactory print quality, replace the BJ cartridge. Note that the ink tanks can only be used for 6 months after the seal is broken.

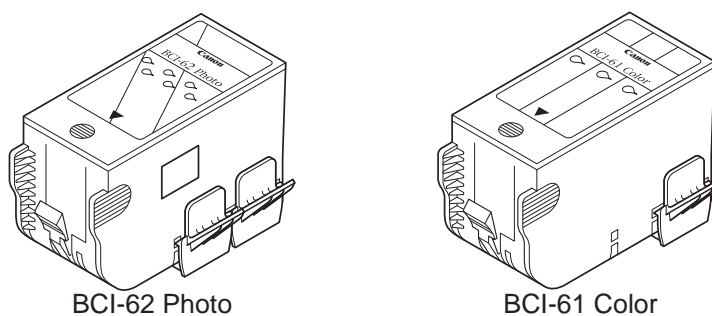

**Figure 2-6 Ink Tanks**



## 2. SPECIFICATIONS

### 2.1 General Specifications

#### 1. Type

Desktop serial color bubblejet printer

#### 2. Operating mode

Canon extended mode

#### 3. Print resolution

1200 (H) × 600 (V) dpi max.

#### 4. Printing speed

##### Burst (BC-60 monochrome)

HQ: 480cps, HS: 720cps

##### Throughput

Monochrome printing: HQ: Approx. 5.8ppm, HS: Approx. 7.6ppm

Color printing: HQ: Approx. 0.5 to 2.1ppm, HS: Approx. 1.3 to 4.4ppm,

FINE: Approx. 0.26 to 0.9ppm

HQ: Default setting of Text mode

HS: Default setting of Draft mode

FINE: Default setting of Auto mode

#### 5. Printing width

218mm max. (Maximum print width when Letter+ size is selected)

#### 6. Line pitch

n/600inch (where n is programmable)

#### 7. Print direction

Select either of Unidirectional or Bidirectional as the printing mode. (See "Part 4: 2.2 Print Mode" (page 4-8))

#### 8. Bit image printing

Data matrix: Canon extended mode: Raster image format

Resolution: Canon extended mode: 300, 600, and 1200dpi

#### 9. Buffer

256KB

#### 10. Interface

IEEE1284-compatible parallel interface

#### 11. Interface cable

Material: AWG28 or thicker

Type: Twisted pair shielded cable

Length: 2.0m max.

#### 12. Interface connectors

Printer: Amphenol 57-40360 or equivalent

Cable: Amphenol 57-30360 or equivalent

**13. Paper Feeding method**

ASF and manual feed: Plain paper, high-resolution paper, envelopes, transparencies, back print film, glossy photo paper, fabric sheets, high-gloss photo film and T-shirts transfer

Manual feed only: Other papers

**14. Sheet feeder capacity**

Plain paper: 130 max.  
 High-resolution paper: 100 max.  
 Envelopes: 15 max.  
 Transparencies: 30 max.  
 Back print film: 10 max.  
 Glossy photo card: 10 max.  
 Glossy photo paper: 1  
 High-gloss photo film: 1  
 Fabric sheets: 1  
 T-shirts transfer 1

**15. Paper sizes**

Cut sheets: Size: A4, B5, A5, Letter, Legal, A4+, Letter+  
 Weight: 64g/m<sup>2</sup> to 105g/m<sup>2</sup> [17 to 28 lbs] (auto sheet feeder),  
 64g/m<sup>2</sup> to 550g/m<sup>2</sup> [17 to 146 lbs] (manual feed)  
 Thickness: 0.8mm max. (manual feed)

Envelopes: COM#10 and DL-size

Recommended plain paper:	Canon bubble jet paper	LC-301
High-resolution paper:	High-resolution paper for color BJ	HR-101
Glossy photo paper:	Glossy photo paper for color BJ	GP-301
High-gloss photo film:	High-gloss photo film for color BJ	HG-201
Glossy photo card:	Glossy photo card for color BJ	FM-101
Transparencies:	Transparencies for color BJ	CF-102
Back print film:	Back print film for color BJ	BF-102
Fabric sheets:	Fabric sheets for color BJ	FS-101
T-shirts transfer:	T-shirts transfer for color BJ	TR-201

**16. BJ cartridge****Black BJ cartridge BC-60**

Nozzles: Two rows of 304 nozzles × 1 color  
 Ink colors: Black ink and ink optimizer (semi-transparent)  
 Service life: Approx. 870 pages per cartridge (when printing standard 1500-character pattern)

**Photo BJ Cartridge BC-62e Photo**

Nozzles: Two rows of 80 nozzles × 3 colors  
 Ink colors: Yellow, magenta, and cyan  
 Photo yellow, photo magenta, and photo cyan  
 Service life (Reference data): Approx. 90 pages per tank (when printing standard photo pattern)  
 Head service life: Approx. 2000 pages (when printing standard photo pattern)

**Color BJ cartridge BC-61**

Nozzles:	One row of 80 nozzles × 3 colors
Ink colors:	Yellow, magenta, and cyan
Service life:	Approx. 275 pages per tank (when printing standard color pattern at 7.5% duty per color)
Head service life:	Approx. 2000 pages (when printing standard color pattern at 7.5% duty per color)

**17. Acoustic noise level**

Approx. 48dB (based on ISO9296 sound pressure level)

**18. Operating environment**

During operation:	Temperature:	5°C to 35°C
	Humidity:	10% to 90% (no condensation)
During storage:	Temperature:	0°C to 35°C
	Humidity:	5% to 90% (no condensation)

**19. Power supply**

USA/Canada: 120VAC, 60Hz

UK/Australia: 240VAC, 50Hz

Europe/China: 220VAC, 50Hz

**20. Power consumption**

During soft-power off mode:	Approx. 7W max.
During idle:	Approx. 8W max.
During printing:	Approx. 45W max.

**21. External dimensions**

467mm (w) × 313mm (d) × 218mm (h)  
(with paper output tray in storage position)

**22. Weight**

Approx. 6.4kg (with AC adaptor installed)

**23. Sensor functions**

Paper out detection:	Yes
BJ cartridge installation detection:	Yes
Waste ink amount detection:	Yes
Paper width detection:	No
BJ cartridge identification:	Yes
Ink-out detection:	Yes

**2.2 Paper Specifications**  
**2.2.1 Paper types**

**TABLE 2-2 PAPER SPECIFICATIONS**

Plain paper

Type	Name	Size	Sheet Feeder	Manual Feed
Class 1	Canon PB (NSK)	A4, B5, A5	○	○
	Canon PB (NDK)	A4, B5, A5	○	○
	Canon NP (Kangas)	A4, B5, A5	○	○
	Canon NP (Neusiedler)	A4, B5, A5	○	○
	Canon NP (BoiseCascade)	LTR, LGL	○	○
	Canon BJ Paper LC-301	A4, B5, LTR, LGL	○	○
Class 2	Xerox 4024 (75g/m <sup>2</sup> )	LTR, LGL	○	○
	Xerox 4024 (95g/m <sup>2</sup> )	LTR, LGL	○	○
	Plover Bond	LTR, LGL	○	○

Special Papers

Type	Name	Size	Sheet Feeder	Manual Feed
Coated Paper	LC-301	A4, LTR	○	○
High-Resolution Paper	HR-101	A4, LTR	○	○
Transparency	CF-102	A4, LTR	○	○
BPF	BF-102	A4, LTR	○	○
Glossy Photo Paper	GP-301	A4, LTR, A4+* <sup>1</sup> , LTR+* <sup>1</sup>	○	○
High-Gloss Photo Film	HG-201	A4, LTR	○	○
Envelopes	COM#10	241 × 105mm	○	○
	DL	220 × 110mm	○	○
Fabric Sheets	FS-101	241 × 356mm	○	○
Other Paper			×	○
T-Shirts transfer	TR-201	A4, A3	○	○

○: OK    ×: NG

\*1: A4+ size paper is a Canon original size paper that, measuring 222.7 × 355.6mm, is slightly larger than A4 size paper. The A4+size paper allows you to print to the full A4 size. The LTR+ size, measuring 228.6 × 337.8mm, similarly allows you to print to the full LTR size.

### 2.2.2 Printing range

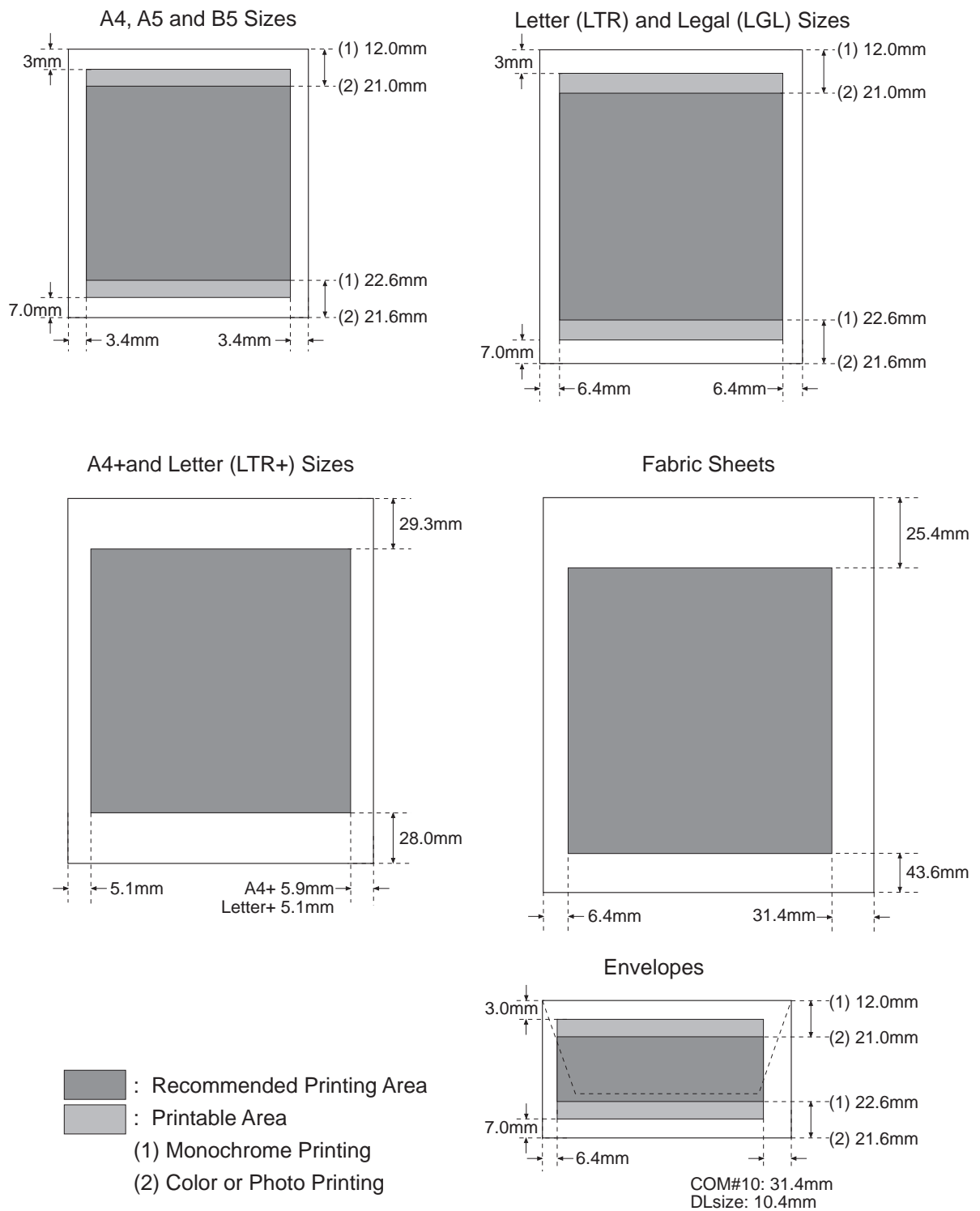

Figure 2-7 Printing Area

## 2.3 Interface Specifications

### 1) Interface type

Bidirectional parallel interface (IEEE1284 compatible)

### 2) Signal level

#### Input

TTL level: Input signals other than to data bus

"Low" level: +0.0V to +0.6V "High" level: +2.4V to +5.0V

TTL level: Data bus

"Low" level: +0.0V to +0.8V "High" level: +2.2V to +5.0V

#### Output

"Low" level: +0.0V to +0.4V

"High" level: +2.4V to +5.25V

### 3) IO

Each signal is pulled up to +5V.

### 4) Interface cable

Material: AWG No. 28 or thicker (American Wire Gauge)

Type: Shielded twisted pair cable

Length: 2.0m max.

### 5) Interface connectors

Printer: Amphenol 36-pin 57-40360 or equivalent

Cable: Amphenol 36-pin 57-30360 or equivalent

### 6) IO signals and pin configuration

TABLE 2-3 IO SIGNALS IN COMPATIBLE MODE

Pin No.	Signal	I/O	Pin No.	Signal	I/O
1	Date-Strobe	IN	19	Data Strobe-RET*2	...
2	Data 1	IN	20	Data 1-RET	...
3	Data 2	IN	21	Data 2-RET	...
4	Data 3	IN	22	Data 3-RET	...
5	Data 4	IN	23	Data 4-RET	...
6	Data 5	IN	24	Data 5-RET	...
7	Data 6	IN	25	Data 6-RET	...
8	Data 7	IN	26	Data 7-RET	...
9	Data 8	IN	27	Data 8-RET	...
10	Acknlg	OUT	28	Acknig-RET	...
11	Busy	OUT	29	Busy-RET	...
12	PE	OUT	30	PE-RET	...
13	Select	OUT	31	Init	IN
14	Auto Feed XT	IN	32	Fault	OUT
15	N.C.*1	...	33	Gnd	...
16	Gnd	...	34	N.C.*1	...
17	Gnd	...	35	Peripheral Logic High*4	...
18	Peripheral Logic High*3	...	36	Select in	IN

\*1: N.C.: No Connection \*2: -RET are All Connected to Gnd.

\*3: Connected to +5.0V Through 390 Resistance.

\*4: Connected to +5.0V Through 3.3k Resistance.

TABLE 2-4 IO SIGNALS IN NIBBLE MODE

Pin No.	Signal	Symbol on Circuit Diagram	I/O	Pin No.	Signal	Symbol on Circuit Diagram	I/O
1	HostClk	[ $\overline{\text{STROBE}}$ ]	IN	19	Signal Gnd	[GND]	...
2	Data 1	[DATA 1]	IN/OUT	20	Signal Gnd	[GND]	...
3	Data 2	[DATA 2]	IN/OUT	21	Signal Gnd	[GND]	...
4	Data 3	[DATA 3]	IN/OUT	22	Signal Gnd	[GND]	...
5	Data 4	[DATA 4]	IN/OUT	23	Signal Gnd	[GND]	...
6	Data 5	[DATA 5]	IN/OUT	24	Signal Gnd	[GND]	...
7	Data 6	[DATA 6]	IN/OUT	25	Signal Gnd	[GND]	...
8	Data 7	[DATA 7]	IN/OUT	26	Signal Gnd	[GND]	...
9	Data 8	[DATA 8]	IN/OUT	27	Signal Gnd	[GND]	...
10	PtrClk	[ $\overline{\text{ACK}}$ ]	OUT	28	Signal Gnd	[GND]	...
11	PtrBusy	[BUSY]	OUT	29	Signal Gnd	[GND]	...
12	AckDataReq	[PE]	OUT	30	Signal Gnd	[GND]	...
13	Xflag	[SELECT]	OUT	31	$\overline{\text{Init}}$	[ $\overline{\text{INIT}}$ ]	IN
14	HostBusy	[AFXT]	IN	32	$\overline{\text{DataAvail}}$	[ $\overline{\text{FAULT}}$ ]	OUT
15	N.C.*1	[N.C.]	...	33	N.C.*1	[GND]	...
16	Gnd	[GND]	...	34	N.C.*1	[N.C.]	...
17	Gnd	[GND]	...	35	N.C.*1	[Peripheral Logic High]	...
18	Vcc	[Peripheral Logic High]	...	36	1284 Active	[ $\overline{\text{SELECT IN}}$ ]	IN

\*1: N.C.: No connection

TABLE 2-5 IO SIGNALS IN ECP MODE

Pin No.	Signal	Symbol on Circuit Diagram	I/O	Pin No.	Signal	Symbol on Circuit Diagram	I/O
1	HostClk	[ $\overline{\text{STROBE}}$ ]	IN	19	Signal Gnd	[GND]	...
2	Data 1	[DATA 1]	IN/OUT	20	Signal Gnd	[GND]	...
3	Data 2	[DATA 2]	IN/OUT	21	Signal Gnd	[GND]	...
4	Data 3	[DATA 3]	IN/OUT	22	Signal Gnd	[GND]	...
5	Data 4	[DATA 4]	IN/OUT	23	Signal Gnd	[GND]	...
6	Data 5	[DATA 5]	IN/OUT	24	Signal Gnd	[GND]	...
7	Data 6	[DATA 6]	IN/OUT	25	Signal Gnd	[GND]	...
8	Data 7	[DATA 7]	IN/OUT	26	Signal Gnd	[GND]	...
9	Data 8	[DATA 8]	IN/OUT	27	Signal Gnd	[GND]	...
10	PeriphClk	[ $\overline{\text{ACK}}$ ]	OUT	28	Signal Gnd	[GND]	...
11	PeriphAck	[BUSY]	OUT	29	Signal Gnd	[GND]	...
12	AckReverse	[PE]	OUT	30	Signal Gnd	[GND]	...
13	Xflag	[SELECT]	OUT	31	$\overline{\text{ReverseReq}}$	[ $\overline{\text{INIT}}$ ]	IN
14	HostAck	[AFXT]	IN	32	$\overline{\text{PeriphReq}}$	[ $\overline{\text{FAULT}}$ ]	OUT
15	N.C.*1	[N.C.]	...	33	N.C.*1	[GND]	...
16	Gnd	[GND]	...	34	N.C.*1	[N.C.]	...
17	Gnd	[GND]	...	35	N.C.*1	[Peripheral Logic High]	...
18	Vcc	[Peripheral Logic High]	...	36	1284 Active	[ $\overline{\text{SELECT IN}}$ ]	IN

\*1: N.C.: No connection

## 7) Description of input/output signals

### Compatible Mode

#### Data Strobe [Input]

This signal is used to read DATA1 to DATA8. The signal becomes valid after the BUSY signal goes Low and the printer outputs an  $\overline{\text{ACKNLG}}$  signal. This signal is normally High. After it goes Low, the printer receives data. When the signal remains Low, the printer does not operate until it goes High.

#### Data 1 to 8 [Input]

The printer receives data with the  $\overline{\text{DATA STROBE}}$  signal.

The state of each bit of the signal must be maintained for at least 0.5 $\mu$ s from the rising edge of the  $\overline{\text{DATA STROBE}}$  signal.

#### Acknlg [Output]

This signal is a response signal to the  $\overline{\text{DATA STROBE}}$  signal.

The host computer does not send the next  $\overline{\text{DATA STROBE}}$  signal until this signal is sent.

When the power is turned on or the BUSY signal goes Low for the input of the  $\overline{\text{INIT}}$  signal, this signal is sent regardless of the  $\overline{\text{DATA STROBE}}$  signal.

#### Busy [Output]

When this signal is High, the printer is BUSY; when Low, the printer is READY.

The printer receives data at least 1 Byte when  $\overline{\text{Data Strobe}}$  signal is input in the case Busy signal goes to "H" regardless of receiving data.

The signal is High in the following cases:

- When receiving data
- When input buffer is full
- When  $\overline{\text{INIT}}$  signal is input
- When carriage is in cartridge replacement position
- During manual cleaning
- When an error occurs (paper-out, paper jam, etc.)
- During soft power on/off sequence
- During internal initialization

#### PE [Output]

This signal goes High when the printer cannot feed paper. The BUSY signal goes High and the SELECT and  $\overline{\text{FAULT}}$  signals go Low.

This signal goes Low when the reset key was pressed and paper is loaded and fed.

The  $\overline{\text{FAULT}}$  and SELECT signals then go from Low to High.

If paper is not ejected (paper jam) after an eject operation, this signal and the BUSY signal go High, and the SELECT and  $\overline{\text{FAULT}}$  signals go Low. In this case, the signals do not change even if the paper is removed manually.

#### Select [Output]

The printer is READY when this signal is High.

This signal goes Low when an error occurs (paper-out, paper jam, etc.) or when the carriage is in the cartridge replacement position.

Fault signal goes to low 50ms after Busy signal goes to high.

#### Auto Feed XT [Input]

This signal is only used for the transition from compatible mode to negotiation mode.



**Init [Input]**

When it changes to Low, this signal sets the printer in the BUSY state, then resets the printer by changing from Low to High.

The pulse width of this signal is required longer than 5 micro seconds.

On completion of initialization, the head retreats to the home position and the default print mode is selected.

**Fault [Output]**

This signal changes to Low when the printer detects an error and when the carriage is in the cartridge replacement position to inform the host computer of the error state.

**Select in [Input]**

This signal is only used for the transition from compatible mode to negotiation mode.

**Nibble Mode****HostClk [Input]**

This is the STROBE signal to read DATA 1 to DATA 8. When in negotiation phase this is the trigger signal to send the protocol confirmation to the printer.

In nibble mode, this signal is always High so that the printer does not fetch data.

**Data 1 to 8 [Input]**

The data bus is not used in nibble mode.

**Ptr Clk [Output]**

The printer requests the host computer to read the data by making the Ptr Clk signal Low in the reverse data transmission phase. After finishing reading, the host computer notifies the printer of completion of data receiving by making the Host Busy AUTO FEED XT signal High.

**Ptr Busy [Output]**

This signal outputs the data to be sent to the host computer in the reverse data transmission phase. First, bit 3 of the transmission byte data is output, followed by bit 7.

**Ack Data Req [Output]**

This signal outputs the data to be sent to the host computer in the reverse data transmission phase. First, bit 2 of the transmission byte data is output, followed by bit 6.

This signal is used as the trigger signal to inform the host computer of the printer's condition in the negotiation phase.

**Xflag [Output]**

This signal outputs the data to be sent to the host computer in the reverse data transmission phase. First, bit 1 of the transmission data is output, followed by bit 5.

This signal informs the host computer whether the printer supports nibble mode in the negotiation phase.

The printer supports nibble mode when this signal level changes to Low at the same time the Ack Data Req (PE) signal rises.

**Host Busy [Input]**

Indicates that the host is ready to receive the data from the printer by making the Host Busy signal Low in the reverse data transmission phase. After that, it goes High when data is received from the printer to verify receiving data.

This signal changes to High in response to the PtrClk (ACKING) signal changing to Low to change to the reverse data transmission phase.

**Init**

This signal is not used in nibble mode.

**DataAvail [Output]**

This signal outputs the data to be sent to the host computer in the reverse data transmission phase. First, bit 0 of the transmission data is output, followed by bit 4.

Informs the host computer if there is reverse transmission data or not in the negotiation phase. If data is ready to be sent to the host computer, this signal changes to Low.

**1284 Active (Input)**

This signal confirms that the printer is an IEEE 1284-compatible device. This signal goes High at the start of the negotiation phase and remains High in nibble mode to indicate that the printer is operating in bidirectional mode. It changes to Low in the termination phase.

**ECP mode****HostClk [Input]**

This is the signal used in handshaking with PeriphAck (BUSY) signal when data is sent from the host computer to the printer.

This signal changes to Low when data has been output to the data bus (Data1 to 8)

This signal changes to High in response to the PeriphAck (BUSY) signal rising. It remains High in the reverse data transmission phase.

**Data 1 to 8 [Input/Output]**

These are input data signals when data is sent from the host computer to the printer.

In the reverse data transmission phase, these are output signals, and the printer outputs data to the host computer using this data bus.

**Periph Clk [Output]**

This signal is always High when data is sent from the host computer to the printer.

In the reverse data transmission phase, this signal changes to Low to indicate that data is output to the host computer. This signal changes to High in response to the HostAck (AUTO FEED XT) signal changing to High.

**Periph Ack [Output]**

When data is sent from the host computer to the printer, this signal changes to Low when the printer is ready to receive data.

When the data has been received from the host computer, this signal changes to High.

In the reverse data transmission phase, this signal indicates if the information output from the printer to the data bus is command information or data (Low: Command information; High: data).

**Ack Reverse [Output]**

This signal remains High when data is sent from the host computer to the printer. It remains Low in the reverse data transmission phase.

When switching from the forward to reverse data transmission phase, this signal changes to Low, to indicate that a request to switch modes has been received, in response to the fall of the  $\overline{\text{Reverse Request}} (\overline{\text{INIT}})$  signal, which is sent by the host computer to request the switch.

This signal changes to High, to indicate that the request to switch modes has been received, when the  $\overline{\text{Reverse Request}} (\overline{\text{INIT}})$  signal rises.

**Xflag [Output]**

This signal is always High in ECP mode.

**Host Ack [Input]**

When data is sent from the host computer to the printer, this signal indicates whether the signal information on the data bus is data or command information (Low: Command information; High: data).

In reverse data transmission, this signal is used for handshaking with the Periph Clk ( $\overline{\text{ACKNLG}}$ ) signal.

When the host is ready to receive data from the printer, this signal changes to Low, then changes to High when the data has been received.

 **$\overline{\text{Reverse Req}}$  [Input]**

This signal changes to Low during the recovery phase (resending data) when data is sent from the host computer to the printer.

This signal changes to High in response to the lowered  $\overline{\text{Ack Reverse}} (\text{PE})$  signal.

This signal changes to Low on transition from the idle state in the forward data transmission phase to the reverse data transmission phase (when data is sent from the printer to the host computer).

When Low, this signal indicates reverse data transmission.

The signal changes to High on transition from reverse data transmission to forward data transmission.

 **$\overline{\text{Periph Req}}$  [Output]**

This signal changes to Low when, during forward data transmission, the printer requests reverse data transmission.

When the host computer changes from forward data transmission to reverse data transmission, this signal changes to High at the same time as the  $\overline{\text{Ack Reverse}} (\text{PE})$  signal in response to the fall in the  $\overline{\text{Reverse Request}} (\overline{\text{INIT}})$  signal, which requests the switch in modes by the host computer.

**1284 Active [Input]**

This signal goes High at the start of the negotiation phase and remains High in ECP mode to indicate that the printer is operating in bidirectional mode. It changes to Low in the termination phase on exiting ECP mode.

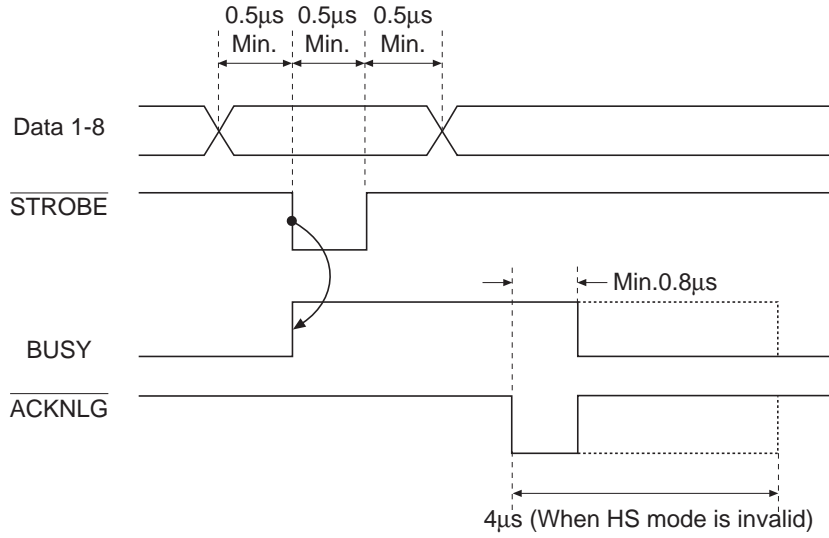

Figure 2-8 Compatible Mode

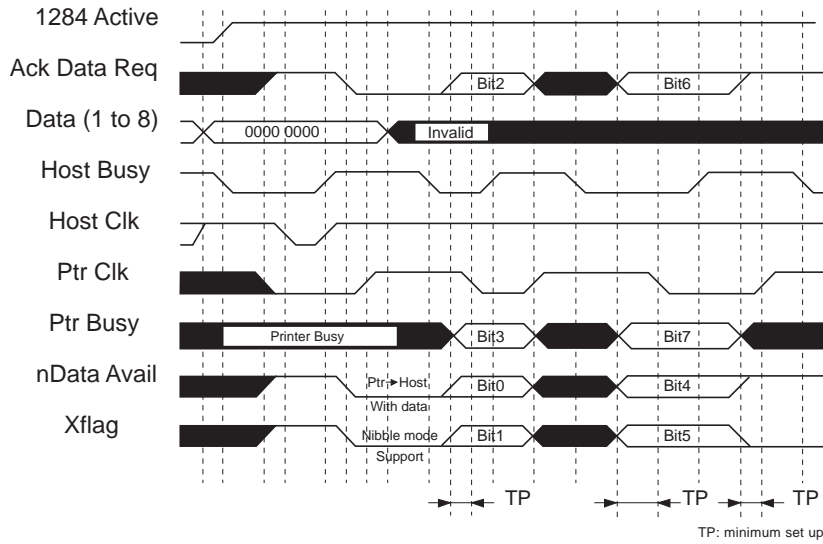

Figure 2-9 Nibble Mode

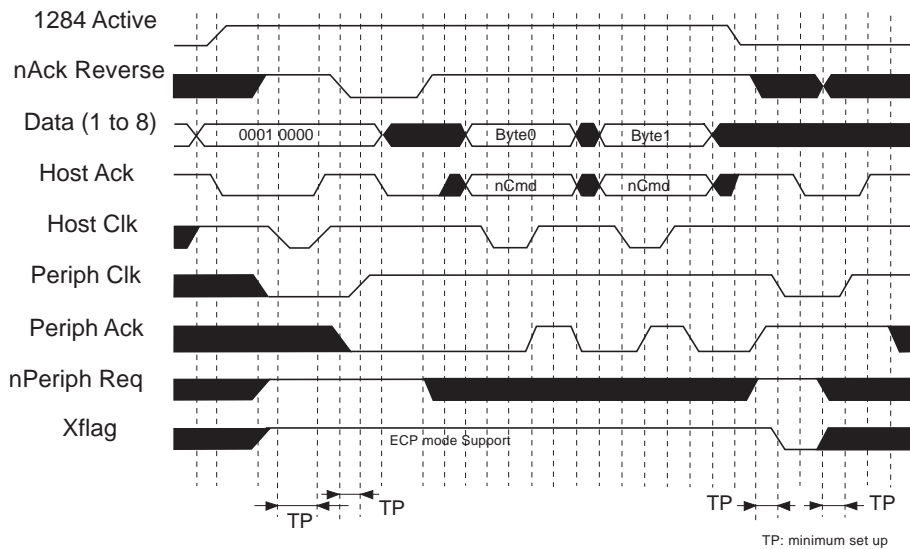

Figure 2-10 ECP Mode



# *Part 3*

## **OPERATING INSTRUCTIONS**

Page	
3 - 1	1. PRINTER SETUP
3 - 1	1.1 Unpacking
3 - 2	1.2 Installation Location
3 - 3	1.3 Installation
3 - 8	1.4 Turning Printer Power On and Off
3 - 9	1.5 Loading Printer Paper
3 -10	1.6 Names of Parts and Their Functions
3 -12	2. TRANSPORTING THE PRINTER
3 -12	2.1 Transporting the Printer
3 -13	2.2 Manual Capping
3 -14	3. PRINTER SERVICING FUNCTIONS
3 -14	3.1 Error Indications
3 -16	3.2 Warning Indications
3 -17	3.3 Function Settings
3 -19	3.4 EEPROM
3 -19	3.5 Cleaning the BJ Cartridge
3 -20	3.6 Test Printout
3 -20	3.7 Pickup Roller Cleaning Function (HR-101)
3 -21	3.8 Service Mode



# 1. PRINTER SETUP

## 1.1 Unpacking

After unpacking, make sure the items below have been included:

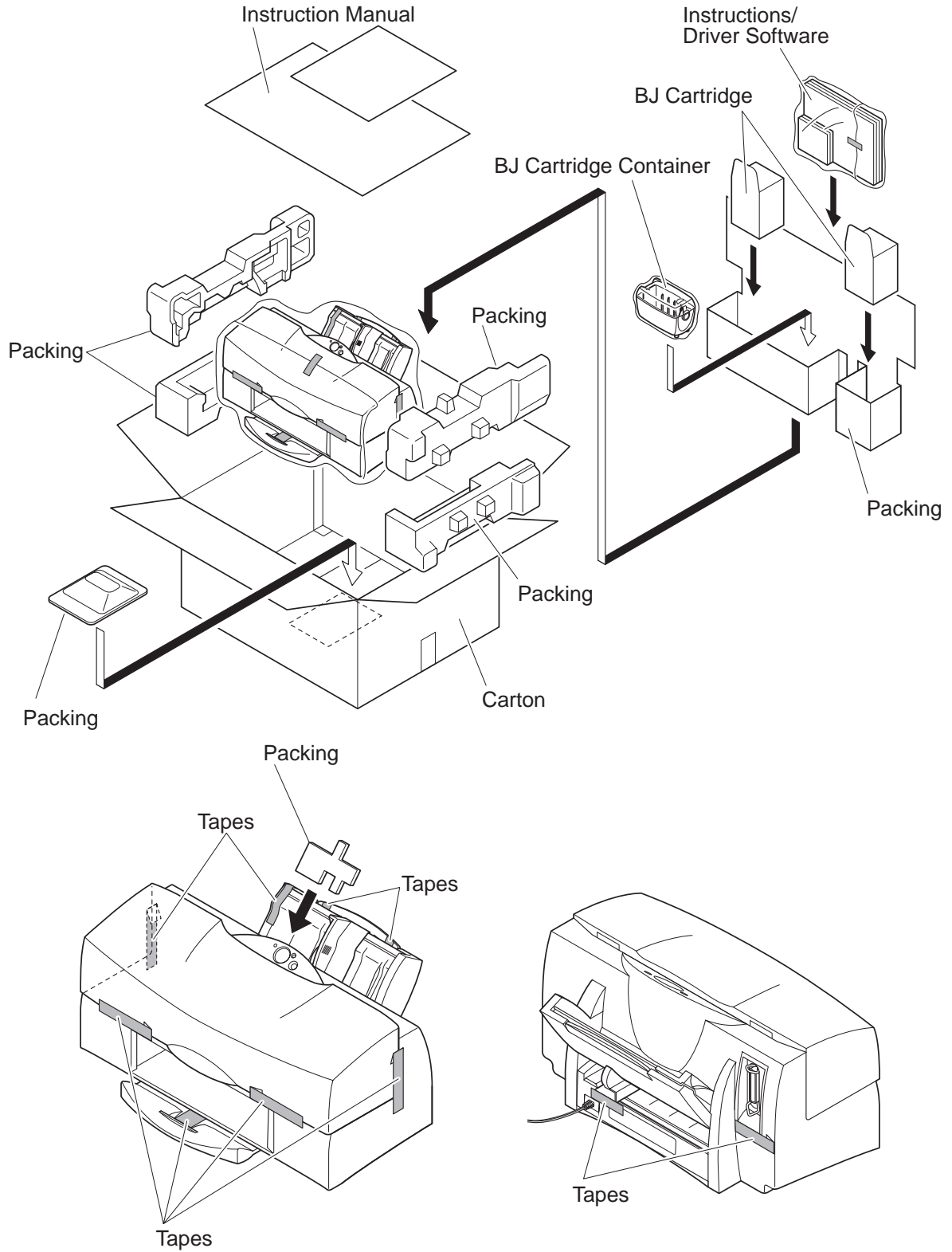
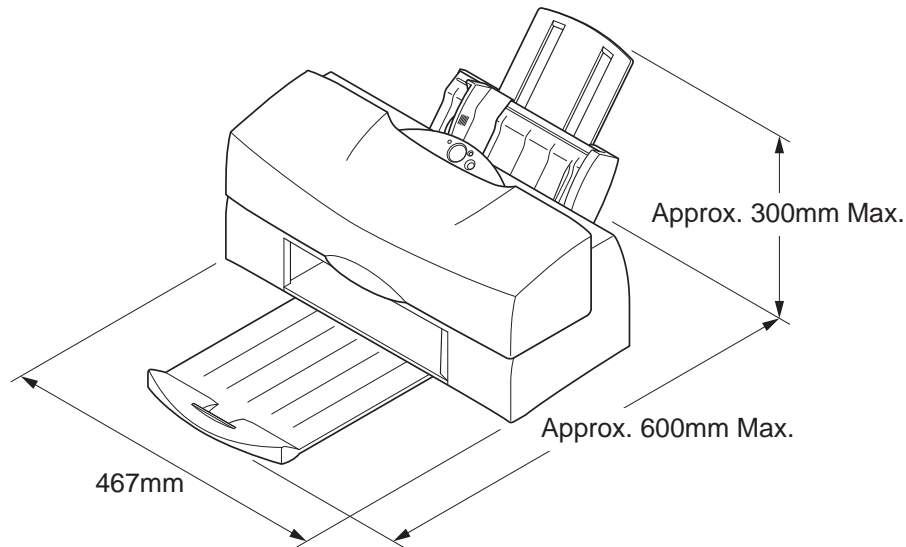

Figure 3-1 Packaging

## 1.2 Installation Location

To ensure optimum performance, install the printer where there is adequate space. It is also important that you install the printer where the vibration caused by the carriage movements will not cause problems. The figure illustrates the printer dimensions.



**Figure 3-2 Printer Dimensions**



---

Use the printer where the ambient temperature is between 5°C and 35°C and the ambient humidity is between 10% and 90% (no condensation). Do not install the printer where it is subject to direct sunlight or where it may be subject to rapid fluctuations in temperature, such as close to air conditioners, etc. Also, do not leave the printer in motor vehicles, etc., where it may be subject to a rapid rise in temperature. Do not install the printer where it may be subject to excessive amounts of dust, or subject to sea breezes or other sources of salinity. Do not install close to TV, speakers, or other sources of storing magnetic fields. Install the printer on a level and stable surface. Avoid locations subject to vibration.

---



---

If you install the printer on a standard PC rack, make sure the rack itself is well secured to avoid excessive vibration during printing.

---



## 1.3 Installation

Set up the printer as follows.

### 1.3.1 Connecting the interface cable

- 1) Make sure both the printer and host PC are OFF.
- 2) Connect the interface cable to the interface connector on the printer. Lock the connector clips.
- 3) Connect the other end of the interface cable to the host PC.

1. Connect the cable to the printer
2. Connect the cable to the computer

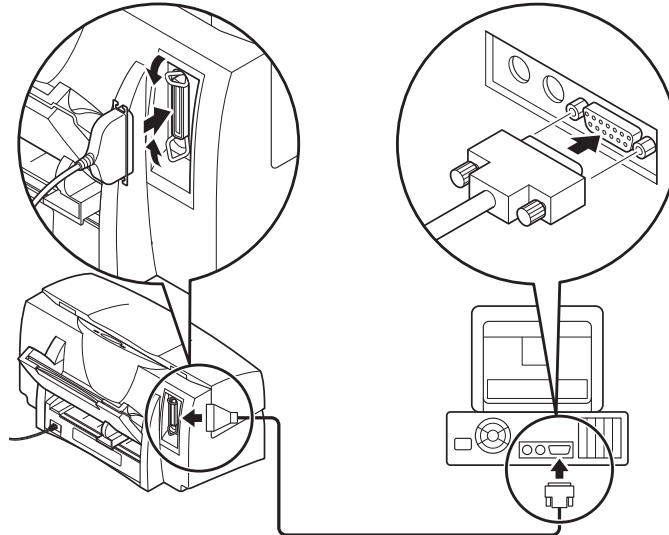

**Figure 3-3 Connecting the Interface Cable**

### 1.3.2 Connecting the power supply

- 1) Connect the power cord to the AC adaptor, then plug the AC power plug into a wall outlet.
- 2) Press the printer *POWER* button. The printer beeper sounds and the power lamp blinks.
- 3) After the printer has initialized itself, the carriage moves to the left for the BJ cartridge to be installed.

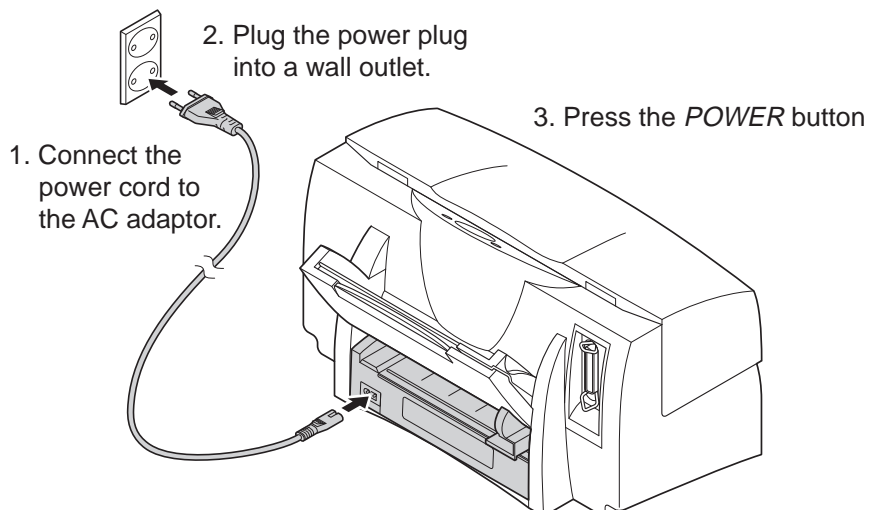
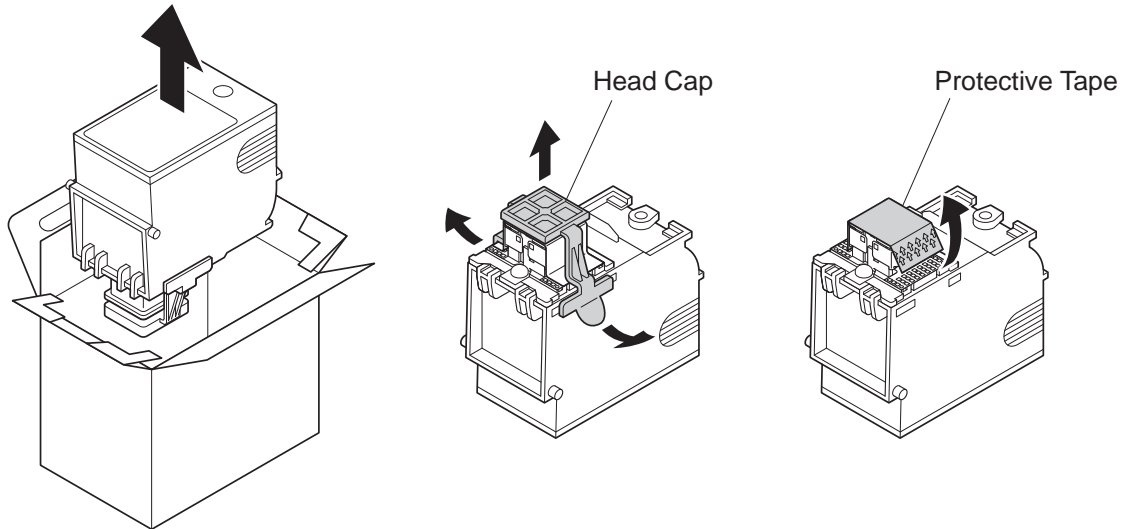

**Figure 3-4 Connecting the Power Supply**

### 1.3.3 Installing the BJ cartridge

#### 1) Removing the BJ cartridge protectors

Remove the BJ cartridge from the package, then remove the cap and tape on the nozzles, as shown in the figure.



**Figure 3-5 Removing Cap and Tape from BJ Cartridge**



Do not reuse the cap and tape. It can clog the nozzles or mix the ink colors.

Do not touch the nozzles when removing the tape as doing so may result in the head becoming scratched and dirt adhering to the head, resulting in poor printing.

Do not shake the BJ cartridge after removing the cap and tape as doing so may result in ink spillage.

#### 2) Installing the BJ cartridge

Open the printer's front cover and install the BJ cartridge on the carriage.

Install the BC-60 on the left holder and the BC-62e Photo (or BC-61) on the right holder.

After installing the cartridge, press the *REPLACE* button. The beeper sounds once and, after about 15 seconds, the carriage returns to the capping position.

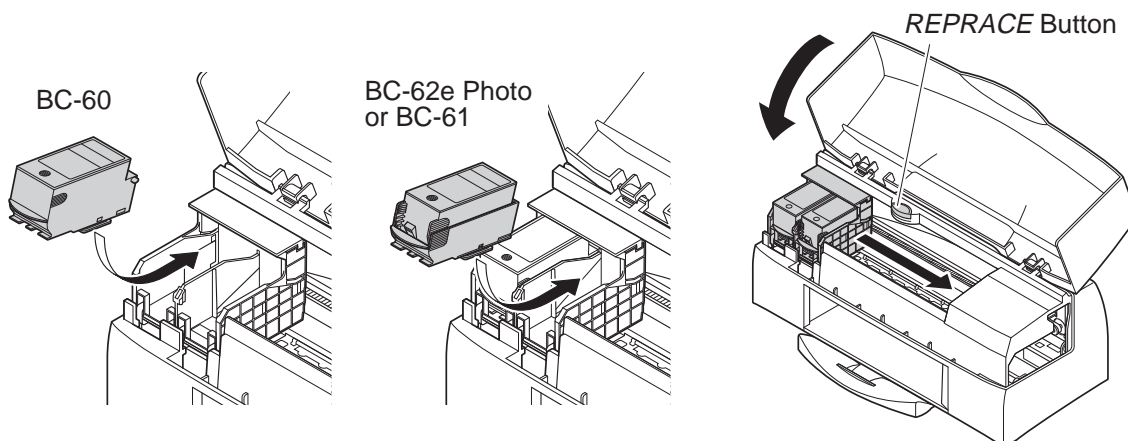

**Figure 3-6 Installing BJ Cartridges**

### 3) Aligning the print heads

Because two BJ cartridges are installed in the printer, differences in how they are secured and in the cartridges themselves can shift the way ink is ejected onto the paper. To even out any differences and ensure satisfactory print quality, follow the procedure below for adjusting the relative positions of the print heads after completing the setup procedure on the PC.

- 1) Load two or more sheets of standard A4-size plain paper into the sheet feeder.
- 2) Following the instructions on the Printer Driver's control sheet, print a Print Head Alignment Pattern.
- 3) Check the printed patterns to select the optimum A (vertical), B (horizontal), C (bidirectional 1) and D (bidirectional 2) alignment values.
- 4) Following the instructions on the Printer Driver's control sheet, print a High-Resolution Adjustment Pattern.
- 5) Check the printed pattern to select the optimum E (horizontal 1), F (bidirectional 1), G (horizontal 2) and H (bidirectional 2) adjustment.
- 6) Following the instructions on the Printer Driver's control sheet, quit the print head alignment procedure.
- 7) You can print the nozzle check pattern to check the print head alignment values after completing this procedure. To print the nozzle check pattern, refer to 3.8 Service Mode (Page 3-21).

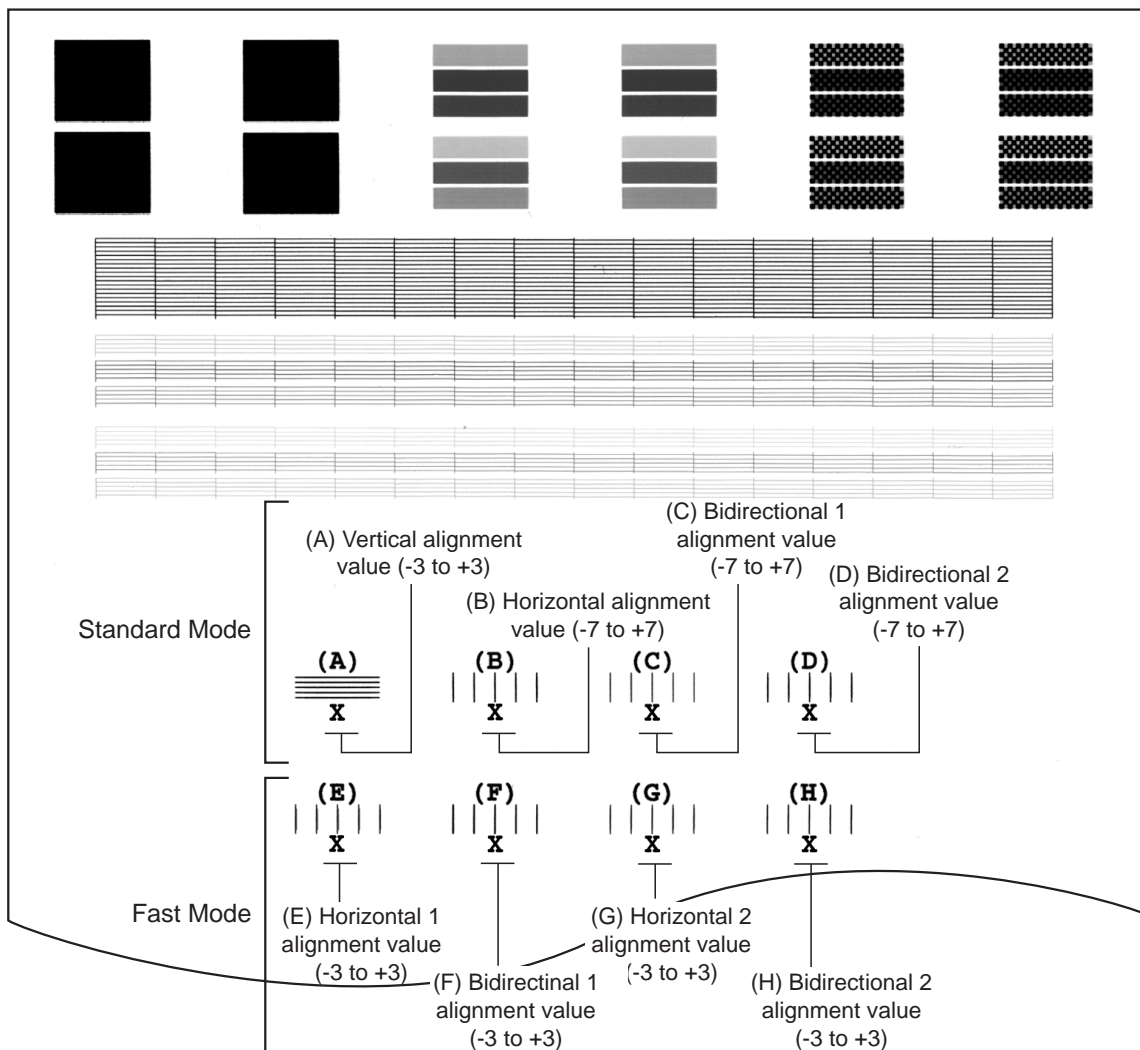

Figure 3-7 Checking Print Head Alignment

### 1.3.4 Replacing the ink tanks

You can replace the ink tanks of the BC-61 and BC-62e Photo BJ cartridges (not the BC-60 BJ cartridge). Replace the ink tanks as described below.

#### 1) When to replace the ink tank

Replace the ink tank in any of the following cases: the ink runs out, the ink tank is out of its package for over six months, and the printing quality does not improve even after the head is cleaned.

The color ink tanks of the BC-61 and BC-62e Photo contain multiple colors; if one ink color runs out, the entire color ink tank must be replaced.

#### 2) Removing an ink tank

Press the *REPLACE* button to move the carriage to the cartridge replacement position (you can also use the printer driver).

As shown in Figure 3-8, lift the front of the ink tank to remove the ink tank from the holder. Do not touch or let your clothing come in contact with the ink feeds on the ink tank.

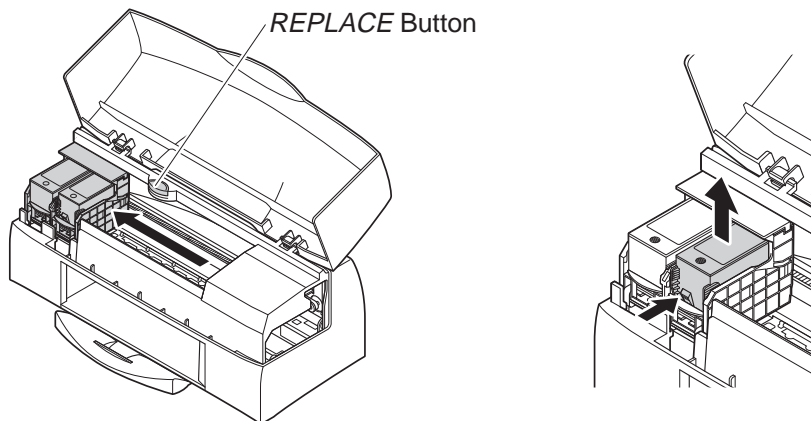
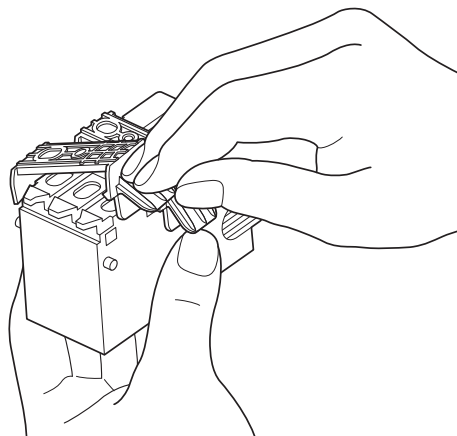

**Figure 3-8 Replacing the Ink Tank**

#### 3) Installing an ink tank

Remove a new ink tank from its box, then remove the cap from the ink feeds as shown in Figure 3-9. Install the ink tank in the holder in the reverse procedure from that described above.

After installing the ink tank in the holder, press the *REPLACE* button to return the carriage to the capping position.



**Figure 3-9 Removing Protective Cap from Ink Tank**

### 1.3.5 Cartridge container [SB-60]

The printer is supplied with a container for storing the BC-61 or BC-62e Photo BJ cartridges for users who are using both the BC-61 and BC-62e Photo. (Note that the BC-60 cannot be stored in the container.)

When the BC-61 is installed in the printer, the BC-62e Photo is stored in the container, and vice versa.

The container can be mounted on the back of the printer.



When storing the BC-61 or BC-62e Photo in the container, make sure the ink tanks are installed in the BJ cartridge holder.

Make sure that the cartridge faces the correct way in the container.

Do not shake or drop the container, as ink may spill.

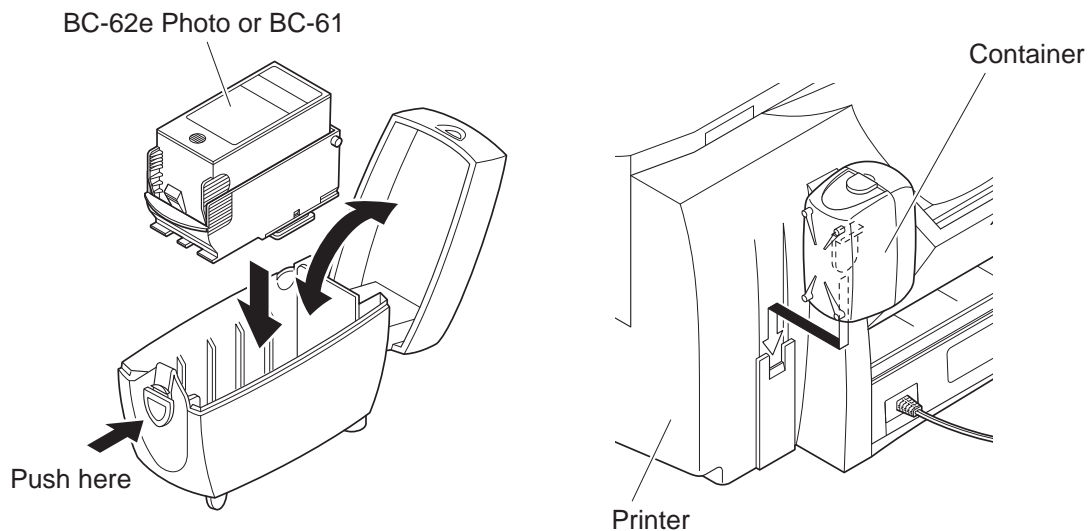

**Figure 3-10 Cartridge Container SB-60**



The BJC-7100 use a range of inks and, when printing on plain paper, an ink optimizer for plain paper is used. The ink optimizer is an almost colorless, transparent fluid.

For simplicity in this manual, we refer to the ink optimizer for plain paper simply as ink optimizer or just optimizer. We also refer to the various colored inks and the ink optimizer for plain paper simply as "inks".

## 1.4 Turning Printer Power On and Off

### 1.4.1 Turning the power on

When the printer is connected to a power supply, press the *POWER* button to turn it ON. The beeper sounds once and the printer initializes itself.

If no BJ cartridge has been installed, the *POWER* indicator blinks to show that the printer is waiting for the cartridge to be installed.

If a BJ cartridge has already been installed when the power is turned on, the *POWER* indicator lights to show that the printer is in standby mode.

When the printer is first turned on after leaving the factory, it automatically performs a cleaning operation. This operation takes about 2 minutes during which the *POWER* indicator blinks to show that cleaning is being performed.

### 1.4.2 Turning the power off

If the printer is ON, press the *POWER* button to turn the printer OFF.

When you turn the printer off, the printer automatically caps the BJ cartridge.

During this sequence, the *POWER* indicator continues to blink. The *POWER* indicator turns off on completion of the power off sequence.

Before unplugging the power cable from the wall outlet, make sure that the *POWER* indicator is off.



Do not unplug the power cable from the wall outlet before turning off the printer using the *POWER* button.

If you unplug the power cable to disconnect the power, the BJ cartridge capping will not be performed and ink may leak and dry on the nozzles, deteriorating the print quality.

If you press the *POWER* button to turn off the power during a cleaning operation, the *POWER* indicator will continue to blink until the cleaning operation has been completed. The power turns off after the cleaning operation has been completed and the nozzles have been capped. Note that any errors occurring after the start of the power off sequence are ignored.

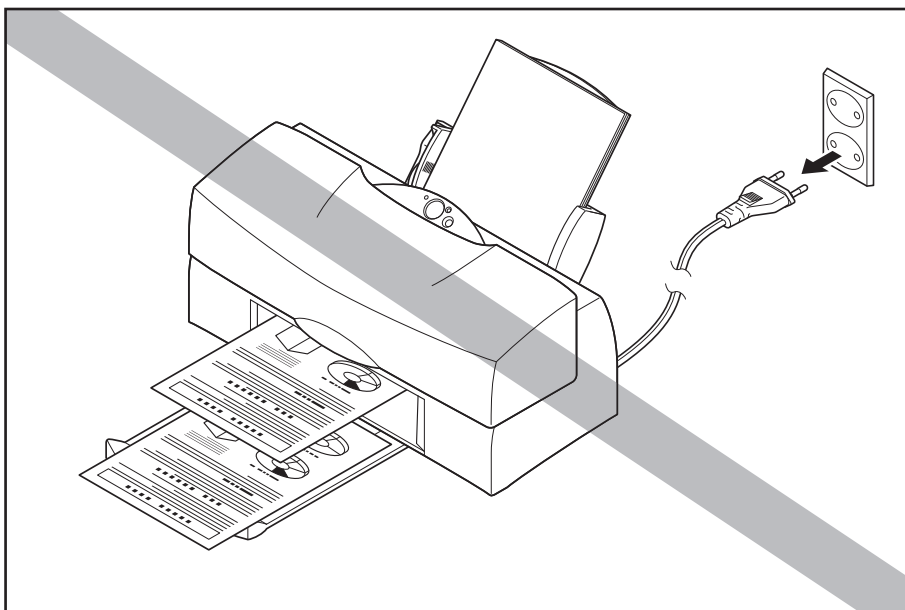

**Figure 3-11 Incorrect Method of Powering Off**

### 1.5 Loading Printer Paper

To obtain optimum print quality, either use the auto sheet feeder or the manual feed on the back of the printer, depending on the type of print paper you are using. Because this printer automatically adjusts the platen-head gap according to the paper being used, there are no paper selection or head gap levers. Note that the paper rest can also be extended to support larger paper sizes.

**TABLE 3-1 PRINTER PAPER SETTINGS**

Paper Type		Size	Feed Method	Sheet Feeder Capacity
Plain Paper	64g to 105g/m <sup>2</sup>	A4/A5/B5/LTR/LGL	Auto/Manual	Approx. 13mm Max.
Plain Paper for Color BJ	Ream Weight LC-301*	A4/A5/B5/LTR/LGL	Auto/Manual	Approx. 13mm Max.
Coated Papers	HR-101*	A4/A5/B5/LTR	Auto/Manual	100 Max.
Glossy Photo Paper	GP-301*	A4/LTR/A4+/LTR+	Auto/Manual	1
High-Gloss Photo Film	HG-201*	A4/LTR	Auto/Manual	1
Transparencies	CF-102*	A4/LTR	Auto/Manual	30 Max.
Back-Print Film	BF-102*	A4/LTR	Auto/Manual	10 Max.
Fabric Sheets	FS-101*	241 (v) × 356 (h) mm	Auto/Manual	1
T-Shirts Transfer	TR-201	A4/A3	Auto/Manual	1
Glossy Photo Card	FM-101	219.5 (v) × 119.6 (h) mm	Auto/Manual	10 Max.
Envelopes	COM#10	241.3 (v) × 105 (h) mm	Auto/Manual	15 Max.
	DL-size	220 (v) × 110 (h) mm	Auto/Manual	15 Max.
Other Papers	106g to 450g/m <sup>2</sup>	150 to 297 (v) ×	Manual	
	Ream Weight (0.8mm thick max.)	150 to 241.3 (h) mm		

Paper sizes: Auto: 100 to 355.6 (v) × 100 to 241.3 (h) mm

Manual: 150 to 297 (v) × 150 to 241.3 (h) mm

Ream weight: Auto sheet feeder: 64 to 105g/m<sup>2</sup>

Manual feed: 64 to 450g/m<sup>2</sup> (0.8mm thick, max.)

\* Indicates papers designed for use in bubble jet printers.

A4+ and LTR+ are Canon original paper sizes.

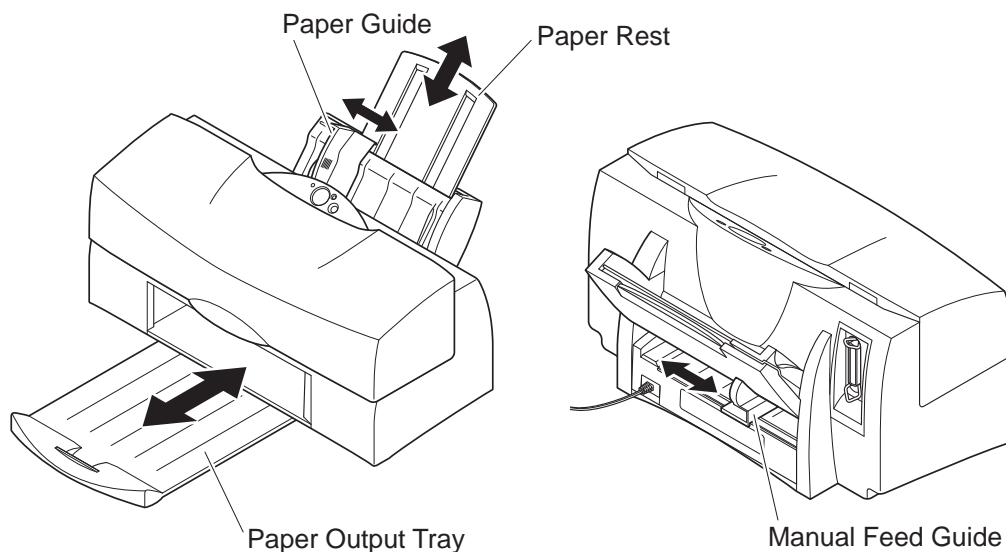

**Figure 3-12 Paper Settings**



### 1.6 Names of Parts and Their Functions

The different parts of the printer and their functions are shown below.

#### FRONT

**Paper Rest**

Supports the stack of paper loaded in the sheet feeder.

**Sheet Feeder**

Print paper is loaded in the sheet feeder. Note that the sheet feeder capacity differs according to the type of paper loaded.

**Paper Guide**

The left edge of the print paper is supported by the paper guide so that the paper remains straight as it is fed through the printer.

**Cover**

Open the cover whenever it is necessary to replace a BJ cartridge, replace an ink tank, or remove jammed paper.

**Paper Output Tray**

Receives the printed paper. When printing large paper sizes, you can extend the tray to support them.

**Operator Panel**

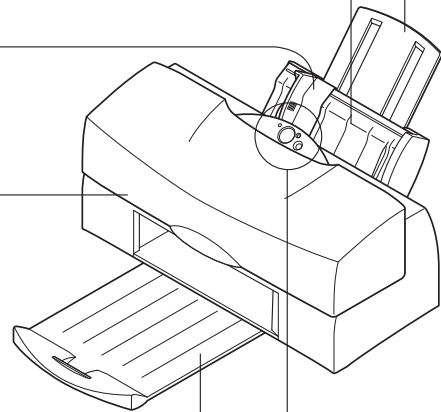

#### OPERATOR PANEL

**POWER Button**

Turns the printer on and off.

**POWER Indicator**

Indicates when the printer is on. The *POWER* indicator blinks when the printer is receiving data and when an error occurs.

**ERROR Indicator**

When an error occurs, the *ERROR* indicator lights or blinks and the buzzer sounds. The number of blinks indicates the type of error that has occurred.

**RESUME Button**

Use the *RESUME* button to reset the printer if a paper jam or other trouble occurs. Also use the *RESUME* button when manually cleaning the nozzles or cleaning the pickup roller with a cleaning sheet within HR-101.

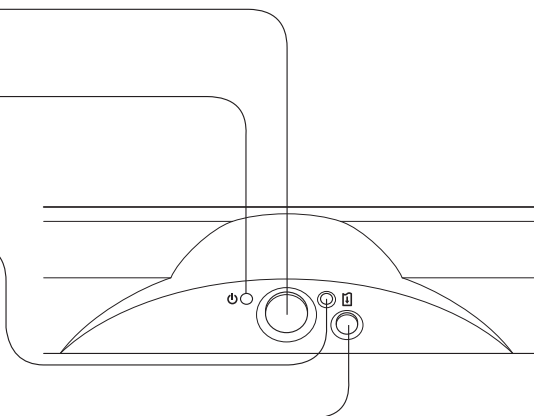
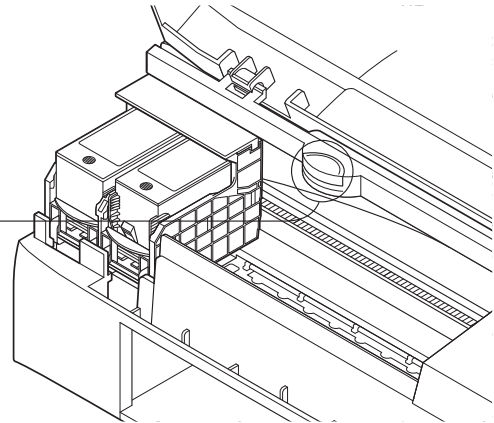

Figure 3-13 Names of Parts and Their Functions (1)



**INSIDE****REPLACE Button**

The *REPLACE* button moves the carriage from the cartridge replacement position to the home position or vice versa.

**BACK****Parallel Interface Connector**

Connects the parallel interface to the PC.

**Manual Feed Slot**

Insert sheets through this slot when manually feeding paper. Lightly support the paper while feeding it straight into this slot.

**Manual Feed Guide**

Adjust the manual feed guide so that it is slightly in contact with the edge of the paper being manually fed. This ensures that the paper is fed correctly.

**AC Adaptor and Power Cable**

Once installed on the printer, the user does not need to remove the AC adaptor when disconnecting the power cord. Plug the power cable into a wall outlet.

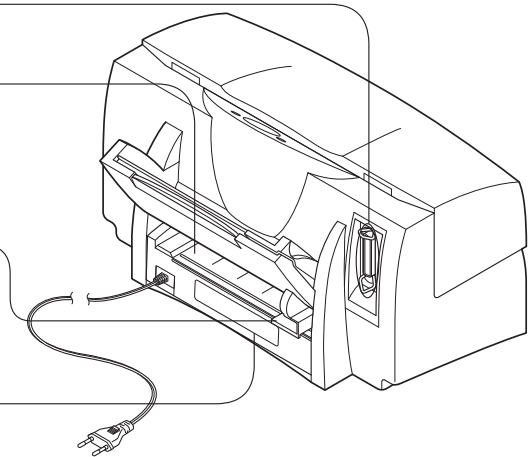

**Figure 3-14 Names of Parts and Their Functions (2)**

## 2. TRANSPORTING THE PRINTER

When carrying or transporting the printer, keep the BJ cartridge installed in the printer or stored in the cartridge container.

This prevents the ink from leaking and drying out in the nozzles.

Also when both BC-61 and BC-62e Photo are in use, keep one cartridge installed in the printer and the other in the container.

### 2.1 Transporting the Printer

When transporting the printer, follow the procedure below:

- 1) Press the *POWER* button to turn off the printer.
- 2) Disconnect the interface cable.
- 3) Unplug the AC adaptor power cable from the wall outlet.
- 4) Open the front cover and check that the carriage is locked in the capping position (right side of printer). If a fault has occurred and the carriage is not in the capping position, move it manually to the capping position. (See below: Operations performed only by service personnel)  
If a fault has occurred and the user has moved the printer without the carriage being locked in the capping position, tape the carriage to the opposite side (left side) of the printer as an emergency measure.
- 5) Close the front cover
- 6) Pack the printer in its original packing materials. Be sure to use cushioning materials.

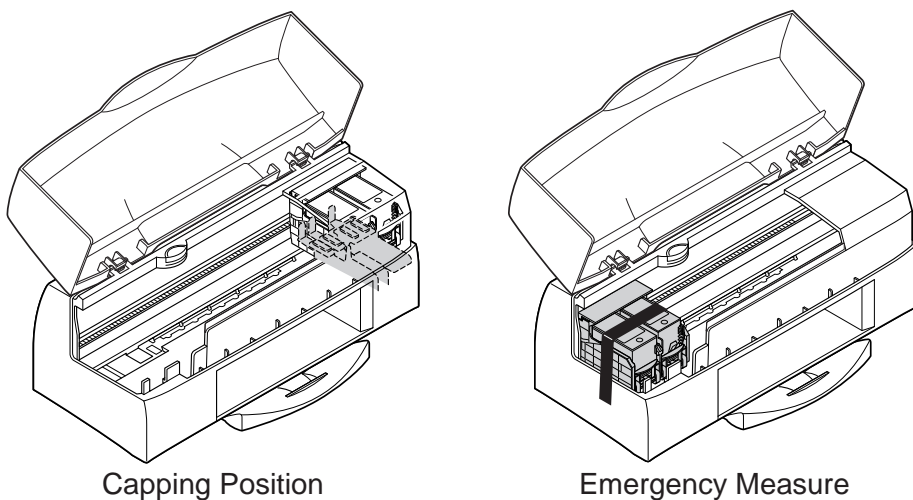
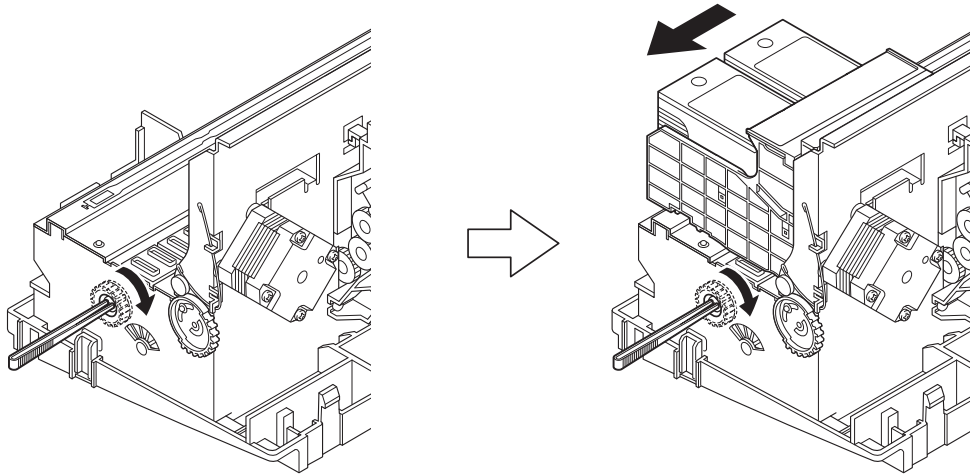

**Figure 3-15 Transporting the Printer**

## 2.2 Manual Capping

The BJ cartridges of the BJC-7100 printer can be capped manually only by service personal.

- 1) Insert a tweezers into the hole for manual capping positioning and rotate the gears slowly counterclockwise.
- 2) When the cap and carriage lock lever are in the lowest position, slowly move the carriage to the capping position. \*
- 3) Next, use the tweezers to slowly rotate the gears counterclockwise. Stop rotating the gears when you can see that capping has been completed.
- 4) The print head is capped and the carriage is locked.



\* : See "CAUTION" on page 1-13.

**Figure 3-16 Manual Capping Method**

## 3. PRINTER SERVICING FUNCTIONS

### 3.1 Error Indications

The indicators in combination with the beeper indicate the nature of any error. There are two types of errors: operator call errors, which can be corrected by the user, and service call errors, which cannot be corrected by the user. The indicators show which type of error has occurred. If an operator call error occurs, the indicators light; if a service call error occurs, the indicators repeatedly blink a specific number of times, depending on symptoms.

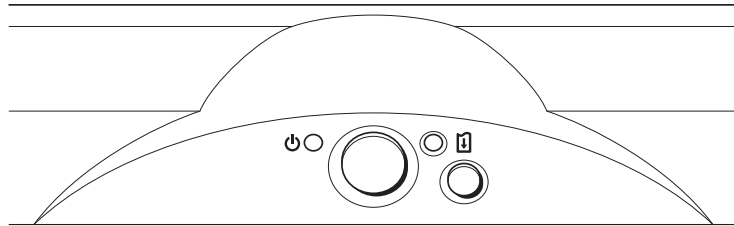

Figure 3-17 Control Panel

#### 3.1.1 Operator call errors

The error is displayed on the computer screen via the printer driver, and you can check the status of the error as shown in the table below by the number of times that the beeper on the main unit sounds. If the error is not corrected by the apparent means, as indicated by the error display, the fault may be elsewhere. In this case, refer to "Part 5: 6. TROUBLESHOOTING" (page 5-13).

TABLE 3-2 OPERATOR CALLS

Error	Error Indicator	Beeper	Description (User Correction)
Paper-Out or Paper-Jam	ON	Twice	No paper loaded for feeding (Load the printer with paper, then press the <i>RESUME</i> button.) Paper Jam (Remove the jammed paper, then press the <i>RESUME</i> button.)
Ink-Out Error	ON	3 times	Black ink or ink optimizer has run out. (Replace BJ cartridge [BC-60].)
Ink-Out Error	ON	4 times	Color or photo ink has run out. (Replace appropriate BJ cartridge or ink tank.)
BJ Cartridge Error	ON	5 times	BJ cartridge not installed correctly. (Install BJ cartridge correctly, then press <i>REPLACE</i> button.)
Waste Ink Alarm *1	ON	6 times	Waste ink or waste ink optimizer exceeds 95% printer capacity. (Press <i>RESUME</i> button.)
BJ Cartridge Overheat Error	ON	7 times	Temperature sensed by diode sensor of print head exceeds prescribed temperature. (Leave printer idle for a moment, then press <i>RESUME</i> button.)

\*1: A waste ink error (service call) will occur if you continue to use the printer.



When using a bidirectional parallel interface (Nibble or ECP Modes), a description of the error is displayed on the host computer's screen.

### 3.1.2 Service calls

In the case of service calls, "service personnel call error messages" are displayed on the host computer's screen via the printer driver, and you can check the details of the error as shown in the table below by the number of times that the beeper on the main unit sounds.

If a service call occurs, refer to "Part 5: 6. TROUBLESHOOTING" (page 5-13).

**TABLE 3-3 SERVICE CALLS**

<b>Error</b>	<b>Error Indicator*1</b>	<b>Beeper</b>	<b>Description (User Correction)</b>	<b>Reference Page</b>
Print Position Alignment Error	Blinks 2 times repeatedly	8 times	Home position not detected during print position alignment operation.	5-16
Home Position Error	Blinks 3 times repeatedly	8 times	Home position not detected other than during print position alignment operation.	5-18
Purge Error	Blinks 4 times repeatedly	8 times	Initial position of purge gear not detected.	5-18
Sheet Feeder Error	Blinks 5 times repeatedly	8 times	Initial position of pickup roller not detected.	5-19
Printer Temperature Error	Blinks 6 times repeatedly	8 times	Printer temperature sensor on carriage board has detected abnormal temperature.	5-20
Waste Ink Full Error	Blinks 7 times repeatedly	8 times	Waste ink amount or waste ink optimizer amount has reached 100% printer capacity.	5-21
EEPROM Error	Blinks 9 times repeatedly	8 times	EEPROM data abnormality.	5-21
ROM Error *2	Blinks 10 times repeatedly	8 times	Abnormality in sum check of control ROM.	5-21
RAM Error *2	Blinks 11 times repeatedly	8 times	Abnormality in DRAM read/write check.	5-21
Carriage Motor Error	Blinks 12 times repeatedly	8 times	Abnormal carriage motor driver temperature.	5-22
Paper Feed Motor Error	Blinks 13 times repeatedly	8 times	Abnormal paper feed motor driver temperature.	5-22
Miscellaneous Hardware Error *2	Blinks 14 times repeatedly	8 times	Other hardware error (detected by head temperature sensor, pickup roller sensor, or purge sensor)	5-23

\*1: The error indicator blinks the number of times indicated in the table, then repeats the same number of blinks.

\*2: The error may not be detected correctly.

## 3.2 Warning Indications

The printer warns the operator of less serious error states by printing out messages and sounding the beeper. Printing is not forcibly stopped while warnings are displayed.

### **BJ cartridge mismatch warning**

If you select the photo ink system using the printer driver controls and start printing with a color BJ cartridge [BC-61] installed, the printer functions as described below.

If you select the standard color ink system using the printer driver controls and start printing with a photo BJ cartridge [BC-62e Photo] installed, it is possible to print, but a message is displayed indicating that it would be preferable to replace the BC-62e Photo cartridge with the BC-61 cartridge.

#### **1) Windows 95/98**

After the printer has received the print data, it displays a warning message on the host computer's screen. Printing does not start. Replace the BC-61 with the BC-62 Photo, then start the print operation.

#### **2) Windows 3.1**

Only the data that can be printed with the color BJ cartridge is printed. By checking the printed page, the operator can see that there has been a BJ cartridge mismatch. Replace the BC-61 with the BC-62e Photo, then start the print operation.

### **BJ cartridge overheat warning (cartridge replacement-inhibited temperature)**

This warning message is displayed when you press the *REPLACE* button or you select BJ cartridge or ink tank replacement via the printer driver's controls but the head temperature sensor has registered a temperature greater than that prescribed for the head.

When this warning is displayed, the printer beeper sounds 4 times and cartridge replacement is halted.

The printer resumes operating when the head temperature has dropped to the prescribed value, or the head has been left for a minimum of 60 seconds without further heating.

### 3.3 Function Settings

This printer has no function selector for setting functions. Use the Windows driver to make the respective settings. For details, see the Windows Driver Guide included with the printer.

#### 3.3.1 Items set by control function

##### Procedure

- 1) Open the printer driver control dialog box.
- 2) Select "Custom Setting" to open the custom setting dialog box.
- 3) Change the parameter of the appropriate setting. (The item is ON when a check mark appears in the checkbox.)

##### Settings

###### a) ECP mode

This setting selects whether or not to be used ECP mode when printing.

"OFF": No ECP mode (default)

"ON": ECP mode

###### b) High speed printing

This setting specifies whether or not to print at high speed by reducing the response of the printer.

"OFF": Normal speed printing

"ON": High speed printing (default)

###### c) Pause page

This setting specifies whether or not to use the function to prevents ink transfer between sheets by specifying a fixed waiting time after printing each page.

"OFF": No pause after printing each page (default)

"ON": Pause after printing each page

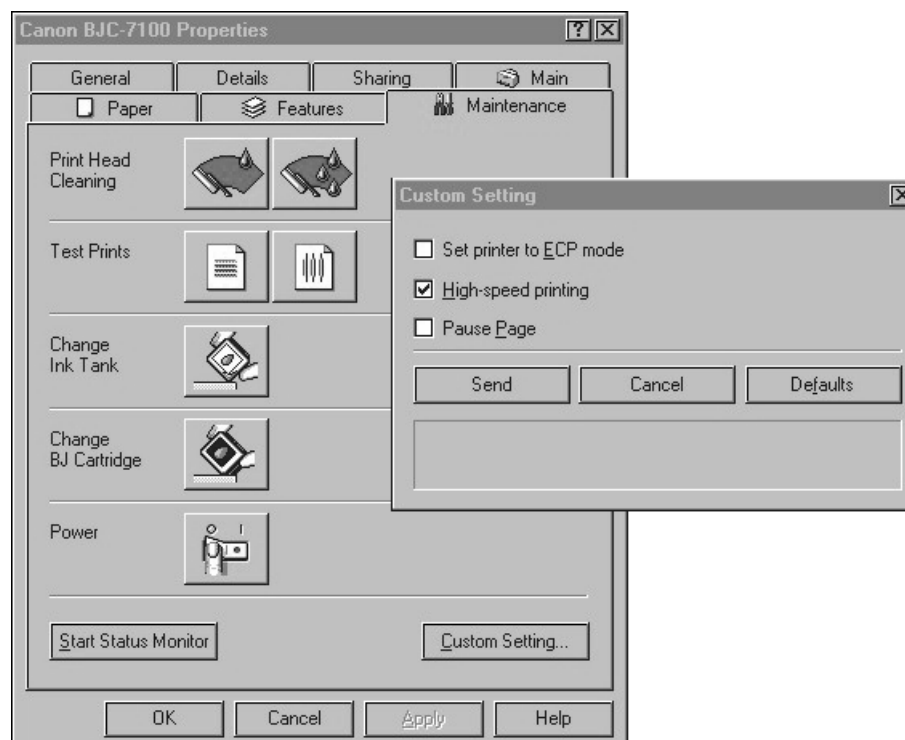

Figure 3-18 Windows 95 Driver Control Sheet (Sample)

### 3.3.2 Service mode of printer driver

There are certain printer driver control functions as service mode. **These service mode functions, which must be used with caution, are provided for service purposes only.**

#### Procedure

- 1) Open the printer driver control dialog box.
- 2) Select "Custom Setting" while pressing down the shift key to open the custom setting dialog box. The dialog box contains the normal and service mode control settings.
- 3) Change the parameter of the appropriate setting. (The item is ON when a check mark appears in the checkbox.)

#### Settings

##### a) Pause scan

This setting specifies whether the carriage pauses between scans (the horizontal travel of the carriage) during printing.

It takes ink longer to dry on transparencies and other special papers than on plain paper, and there is therefore a risk under certain ambient conditions of a drop in print quality. If the pause is set ON under such circumstances, the ink has a chance to dry between scans. However, printing takes much longer.

##### b) Economy cleaning (skip first power-on cleaning)

This setting determines if cleaning is performed when the power is first turned on after the power is connected.

"OFF": First power-on cleaning performed (default)

"ON": First power-on cleaning not performed

If the AC power supply is frequently disconnected (such as when the printer is linked to a computer's power supply), setting economy cleaning ON reduces ink consumption and minimizes the startup time by omitting the first power-on cleaning. When economy cleaning is set ON, the power-on cleaning using the 72-hour timer is also omitted, and there is a serious risk of a drop in print quality if the printer is left unused for a relatively long time.

##### c) Ink-out detection

This setting determines if the ink out detection function is on or off.

"ON": Ink out detection function on (default)

"OFF": Ink out detection function off

Make sure the ink out detection function is on unless dealing with a user who does not want this function or you are checking for malfunctions in the detection system.

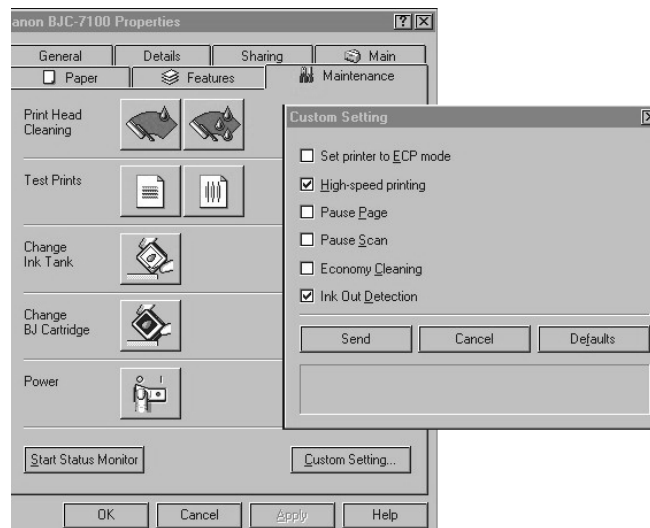

Figure 3-19 Hidden Control Sheet (Sample)



### 3.4 EEPROM

The EEPROM stores data such as the total page count, BJ cartridge installation/removal count, total waste ink amount, and custom settings. The page count and waste ink amount indicate the frequency with which the printer is used. The EEPROM must be reset when the logic board, EEPROM, or waste ink absorbers are replaced. See "Part 5: 4.3 Waste Ink Absorbers" (page 5-6) for details of replacing the waste ink absorbers.

### 3.5 Cleaning the BJ Cartridge

If the printed page shows faults such as white lines or fragmentation, print a nozzle check pattern to see if the print head nozzles are clogged. If they are, operate cleaning function for the BJ cartridge to clear the nozzles, as described below.

In addition to cleaning the print heads using online operations via the printer driver, the BJC-7100 also allows you to manually clean the heads using the *RESUME* button. Note, however, that if you perform manual cleaning, the heads of both BJ cartridges installed in the printer are cleaned. (You can clean just one of the heads if you use the printer driver.)

#### Manual Print Head Cleaning

- 1) With the printer power ON, press the *RESUME* button until the beeper sounds once.
- 2) The *POWER* indicator blinks. (Any paper in the printer is ejected.)
- 3) Both BJ cartridges installed in the printer are cleaned.
- 4) On completion of cleaning, the beeper sounds and the *POWER* indicator lights continuously.

#### Deep Cleaning

If after performing normal cleaning, the print quality is still not satisfactory, perform deep cleaning.

Deep cleaning uses more ink than normal cleaning.

- 1) With the printer power ON, press the *RESUME* button until the beeper sounds twice.
- 2) The *POWER* indicator blinks. (Any paper in the printer is ejected.)
- 3) Both BJ cartridges installed in the printer are deep cleaned.
- 4) On completion of deep cleaning, the beeper sounds and the *POWER* indicator lights continuously.

The printer also automatically performs cleaning operations at the following times:

- 1) The first time the power is turned on with the *POWER* button after the AC power is connected when the heads are not capped;
- 2) When a BJ cartridge or ink tank is replaced;
- 3) When an ink-out error is detected (ink-out detection → cleaning → ink-out detection → display)
- 4) The first time the power is turned on with the *POWER* button after 72 hours or more has elapsed since the last cleaning or deep cleaning operation;
- 5) When the dot count exceeds the prescribed value during printing.

### 3.6 Test Printout

This printer has a built-in self-test function that can be executed without any connection to a computer.

With the power off, press and hold the *POWER* button until the beeper has sounded twice. Release the *POWER* button to start the test print.

If you print the nozzle check pattern on plain paper, you will not be able to check the printing of the ink optimizer, which is semi-transparent.

In this case, check the checker pattern at the top right of the nozzle check pattern for ink smears to see the general status of ink optimizer jetting.

If you need to check each nozzle for ink optimizer, print the nozzle check pattern on transparency material for bubble jet printers. Check the reflected light from the pattern to check the status of the nozzles. If it is difficult to see, coat the back surface with black ink, etc., or position the transparency on black paper. If you print a nozzle check pattern with the BC-61 cartridge installed, the part printed by the photo head shown in Figure 3-20 will not be printed.

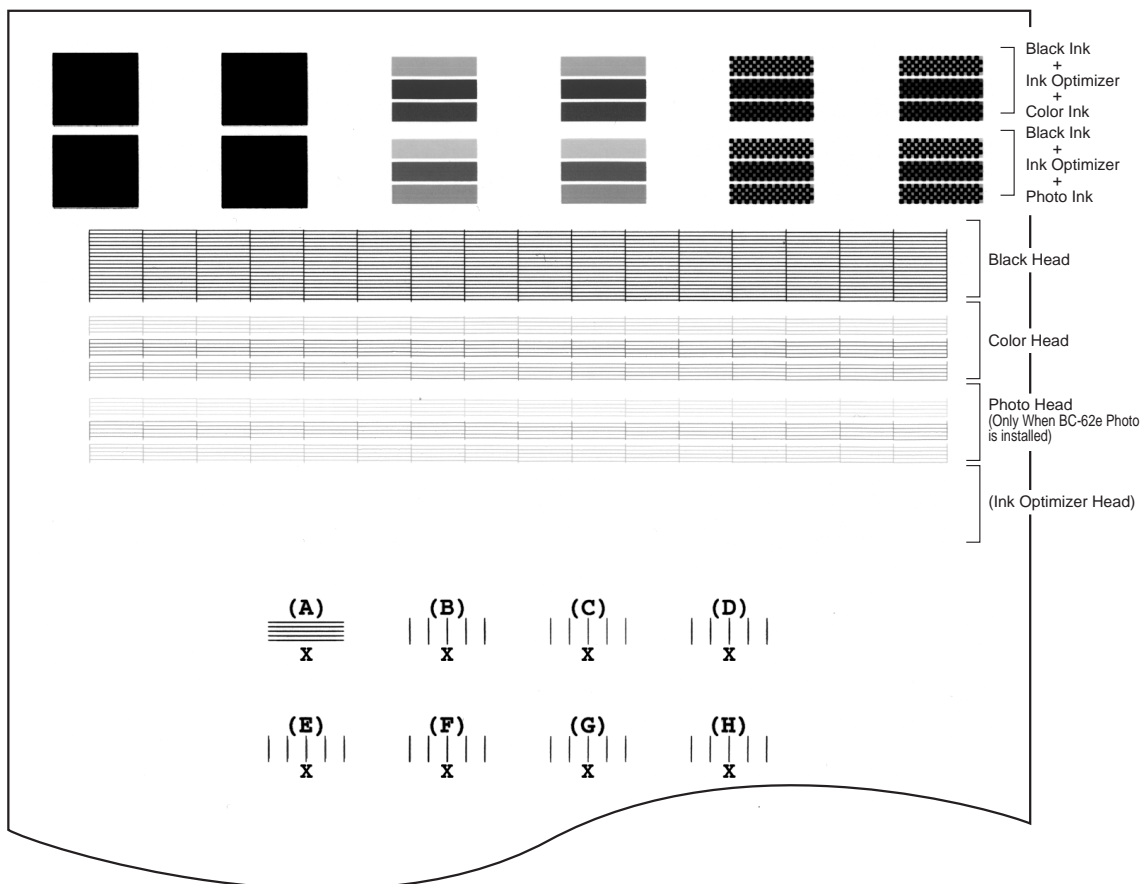

Figure 3-20 Nozzle Check Pattern (Sample)

### 3.7 Pickup Roller Cleaning Function (HR-101)

Use this function to clean the pickup roller when using the pickup roller cleaning sheet supplied with the high-resolution paper (HR-101).

- 1) Insert a sheet of cleaning sheet into the printer.
- 2) With the printer power ON, press the *RESUME* button until the beeper sounds four times.
- 3) The *POWER* indicator blinks. (Any paper in the printer is ejected.)
- 4) Paper loading and ejecting operations are performed.
- 5) On completion of roller cleaning, the beeper sounds and the *POWER* indicator lights continuously.

### 3.8 Service Mode

Use the control buttons to select printer service mode.

In Service Mode, you can, in addition to resetting the EEPROM data, execute the functions shown in Table 3-4.

- 1) While holding down the *RESUME* button, press the *POWER* button to turn on the printer.
- 2) Holding down the *POWER* button, press the *RESUME* button twice before the printer completes its initialization sequence (while the *POWER* indicator is blinking).
- 3) On completion of the initialization sequence, press the *RESUME* button the number of times required to select the desired function.
- 4) Press the *POWER* button to execute the selected function.

**TABLE 3-4 SERVICE MODE**

Function	RESUME Button Count	ERROR Indicator	Remarks	Reference Page
Quit Service Mode	none	OFF		—
Print Final Factory Test Pattern.	Once	ON	Prints continuous A4-wide pattern. Stops printing when you turn off the power.	3-22
Reset EEPROM All Service Data.	Twice	OFF	Power is automatically turned off on completion.	3-22
Reset EEPROM Waste Ink Amount Data.	3 times	ON	Power is automatically turned off on completion.	3-22
Print EEPROM Data.	4 times	OFF	Power is automatically turned off on completion.	3-23
Change Country of Destination.	5 times	ON	See section 3.8.4.	3-23
Print Durability Pattern for plain paper.	6 times	OFF	Prints continuous A4-wide pattern. Stops printing when you turn off the power.	3-24
Print Durability Pattern for glossy photo paper.	7 times	ON	Power is automatically turned off on completion.	3-24
Print LF Check Pattern.	8 times	ON	Prints continuous A4-wide pattern. Stops printing when you turn off the power.	3-24
Quit Service Mode	9 times or more	OFF	Restores normal mode. Use when cancelled.	—

### 3.8.1 Final factory test pattern

Print out printing pattern as Figure 3-21.

See that "BJC-7100 Vx.xxx" is printed at left top on the final factory test pattern.

"BJ F800 Vx.xxx" is printed if the machine is set as model for Japan.

- 1) Enter to a service mode. See "3.8 Service Mode" (page 3-20).
- 2) Press the *RESUME* button once (*ERROR* indicator turns on).
- 3) Press the *POWER* button to print the final factory test pattern.
- 4) To quit printing the test pattern, press *POWER* button.

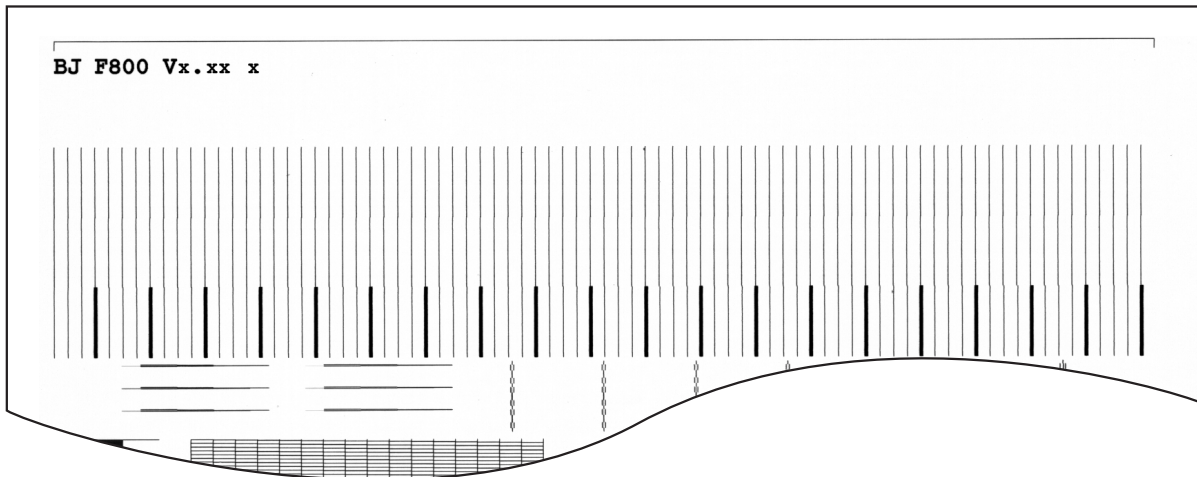

Figure 3-21 Service Mode Test Print (Sample)

### 3.8.2 Resetting EEPROM data

#### 1) Total waste ink amount data reset

The data on total waste ink amount stored in the EEPROM is used for detecting when the waste ink absorbers are full. This data must therefore be reset when you replace the waste ink absorbers.

- 1) Enter to a service mode. See "Part 3: 3.8 Service Mode" (page 3-21) for details of replacing the waste ink absorbers.
- 2) Press the *RESUME* button twice (*ERROR* indicator turns off).
- 3) Press the *POWER* button to reset the total waste ink amount recorded in the EEPROM.
- 4) After resetting the total waste ink amount, the printer automatically turns off.

#### 2) All service data reset

If, when you replace the logic board, you do not intend to continue using the existing EEPROM data, reset all the service data in the EEPROM on the new logic board, and replace the waste ink absorbers and maintenance jet absorbers.

- 1) Enter to a service mode. See "Part 3: 3.8 Service Mode" (page 3-20).
- 2) Press the *RESUME* button three times. (the *ERROR* indicator turns on).
- 3) Press the *POWER* button to reset all service data recorded in the EEPROM.
- 4) After resetting the data, the printer automatically turns off.

The following data are reset:

- Waste ink amount
- Page count
- Cartridge installation/removal count
- Number of recovery operations
- B JL command settings (to factory settings)

### 3.8.3 Printing EEPROM data

You can use the following self-print test to check the data recorded in the EEPROM.

#### Printing EEPROM Data

- 1) Enter to a service mode. See "Part 3: 3.8 Service Mode" (page 3-21).
- 2) Press the *RESUME* button four times. (The *ERROR* indicator turns off.)
- 3) Press the *POWER* button to print the EEPROM data on completion of the printer initialization sequence. All EEPROM data is printed in hexadecimal dump format.

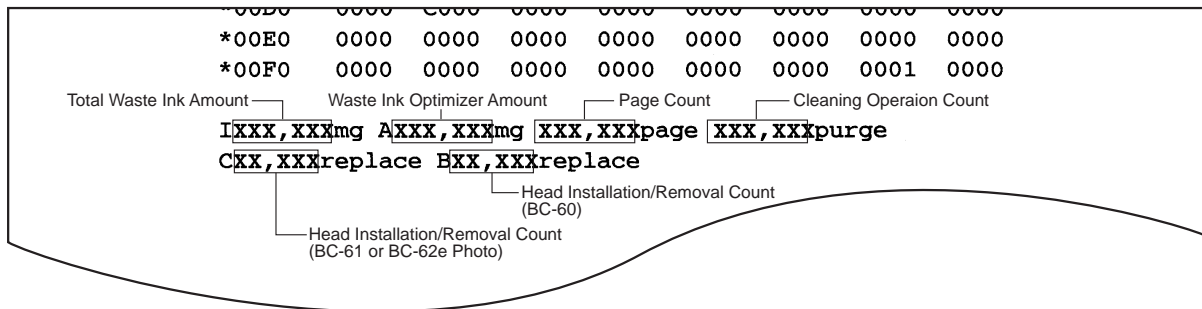

Figure 3-22 EEPROM Data Print (Sample)

### 3.8.4 Setting destination country

This printer has functions designed for use domestic model BJ F800 and international model BJC-7100. The destination country flag is set in the EEPROM to select the relevant function set.

Check that "BJC-7100 Vx.xx Vx.xx x" is displayed at the top left of the test pattern. When set to the Japanese function set, "BJ F800 Vx.xx Vx.xx x" is displayed.

If the printer has been set for the BJ F800 set, reselect the overseas function set as follows:

- 1) Enter to a service mode. See "Part 3: 3.8 Service Mode" (page 3-21).
- 2) Press the *RESUME* button five times. (The *ERROR* indicator turns on.)
- 3) Press the *POWER* button to select the destination setting.
- 4) Press the *POWER* button. (If the printer has been set for BJ F800, the *ERROR* indicator turns off. If set for BJC-7100, the *ERROR* indicator turns on. If the *ERROR* indicator turns off, skip to 6.)
- 5) Press the *RESUME* button once to change the destination setting and to turn the printer off automatically. (Skip to 7.)
- 6) Press the *POWER* button to turn the printer off.
- 7) Make a test print in service mode to check the destination country setting.



After resetting the EEPROM data or writing data to the EEPROM after it has been reset, be sure to print and check the data settings.

### 3.8.5 Other Function

The following functions are provided in addition to the functions described above. These functions are for carrying out special tests, and are not used during normal servicing.

They are described here for reference only.

#### 1. **Print Durability pattern for plain paper**

This function continuously prints patterns one sheet at a time for checking the head alignment accuracy, skew feed and overall scaling on plain paper.

#### 2. **Print Durability pattern for glossy photo paper**

This function continuously prints patterns one sheet at a time for checking the head alignment accuracy, skew feed and overall scaling on glossy photo paper.

#### 3. **Print LF check pattern**

This function continuously prints patterns one sheet at a time for checking line feed accuracy.

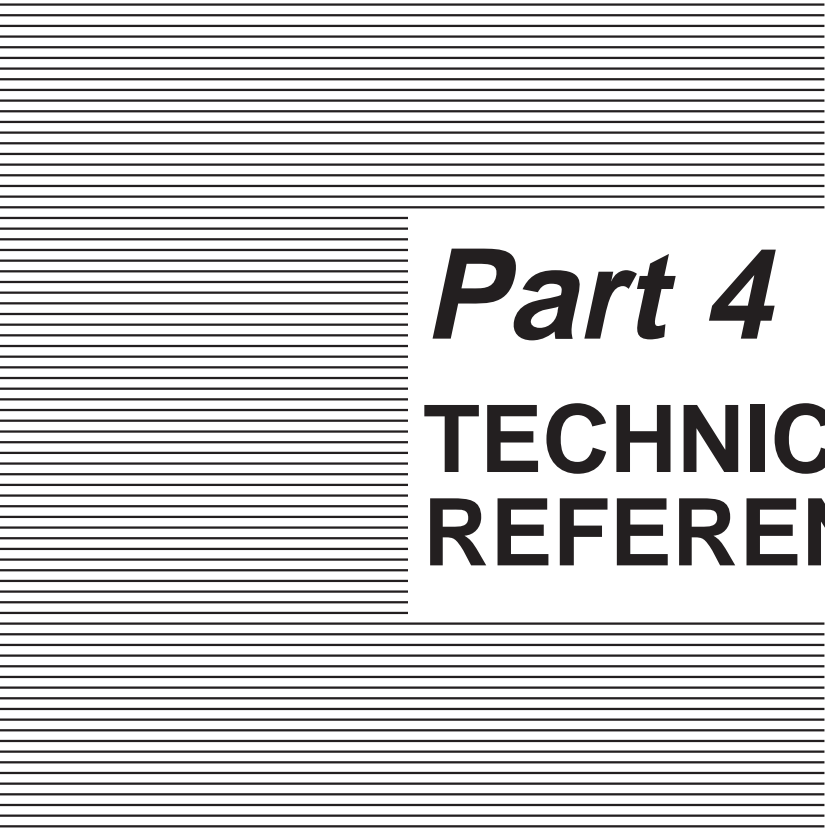

# *Part 4*

## **TECHNICAL REFERENCE**

Page	
4 - 1	1. OVERVIEW
4 - 1	1.1 Printer Block Diagram
4 - 2	1.2 Initial Flowchart
4 - 3	1.3 Print Signal Sequence
4 - 4	1.4 BJ Cartridge Drive
4 - 5	1.5 Power-Off Sequence Flowchart
4 - 6	2. FIRMWARE
4 - 6	2.1 Interface
4 - 8	2.2 Print Modes
4 -11	2.3 Smoothing Function
4 -11	2.4 Print Optimization Controls
4 -12	2.5 Head Overheat Protection
4 -13	3. PRINTER'S MECHANICAL SYSTEM
4 -13	3.1 Overview
4 -15	3.2 BJ Cartridge
4 -29	3.3 Purge Unit
4 -33	3.4 Carriage
4 -36	3.5 Paper Feed/Sheet Feeder Mechanism
4 -39	4. PRINTER ELECTRICAL SYSTEM
4 -39	4.1 Overview of Printer Electrical System
4 -40	4.2 Logic
4 -45	4.3 Electrical System
4 -46	5. DETECTION FUNCTIONS
4 -46	5.1 Sensor-based Detection Functions
4 -48	5.2 Miscellaneous Detection Functions





# 1. OVERVIEW

## 1.1 Printer Block Diagram

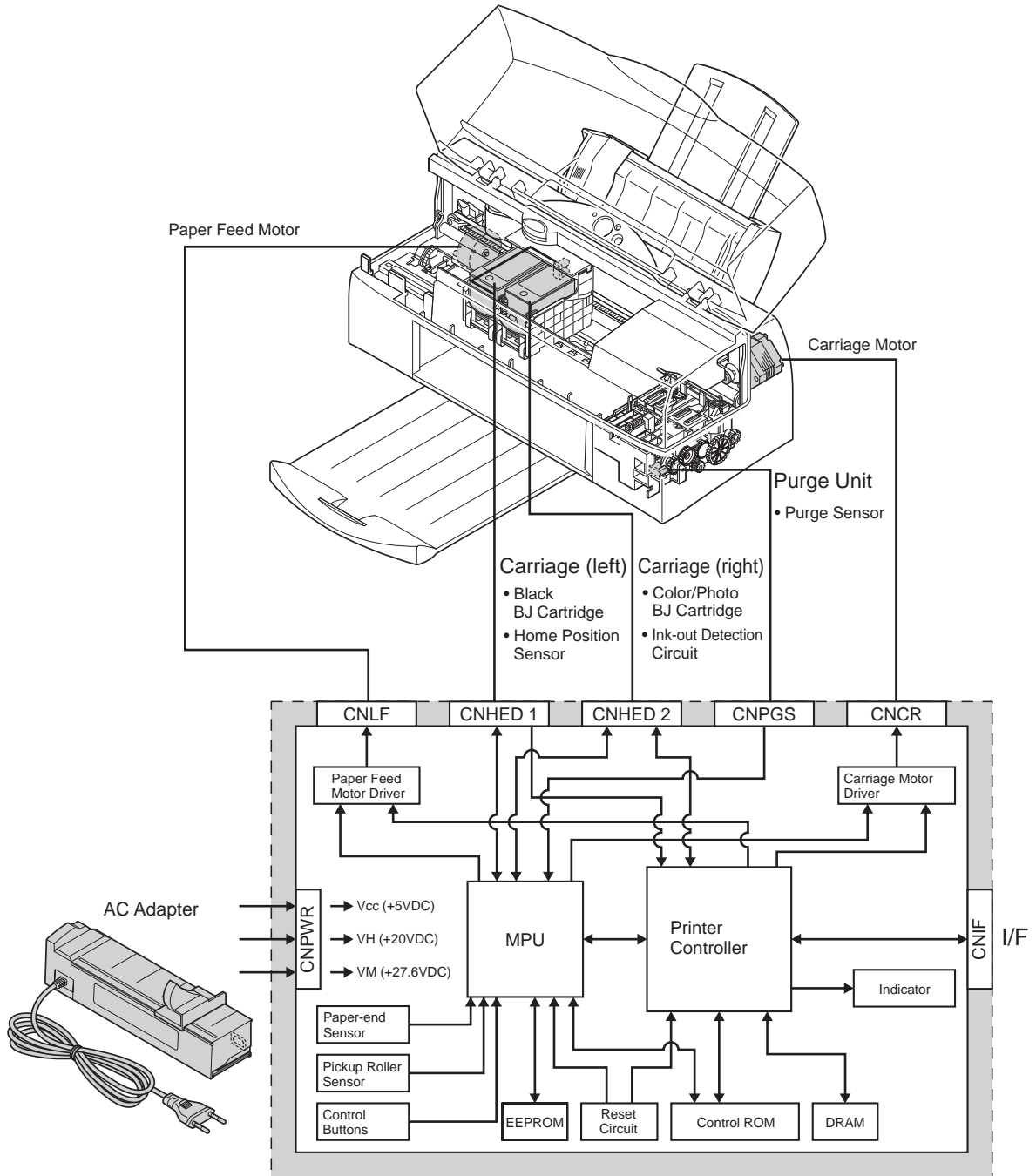

Figure 4-1 Printer Block Diagram

### 1.2 Initial Flowchart

The following flowchart shows the steps in the initialization sequence that takes place when the power is turned on and before the printer enters the online state.

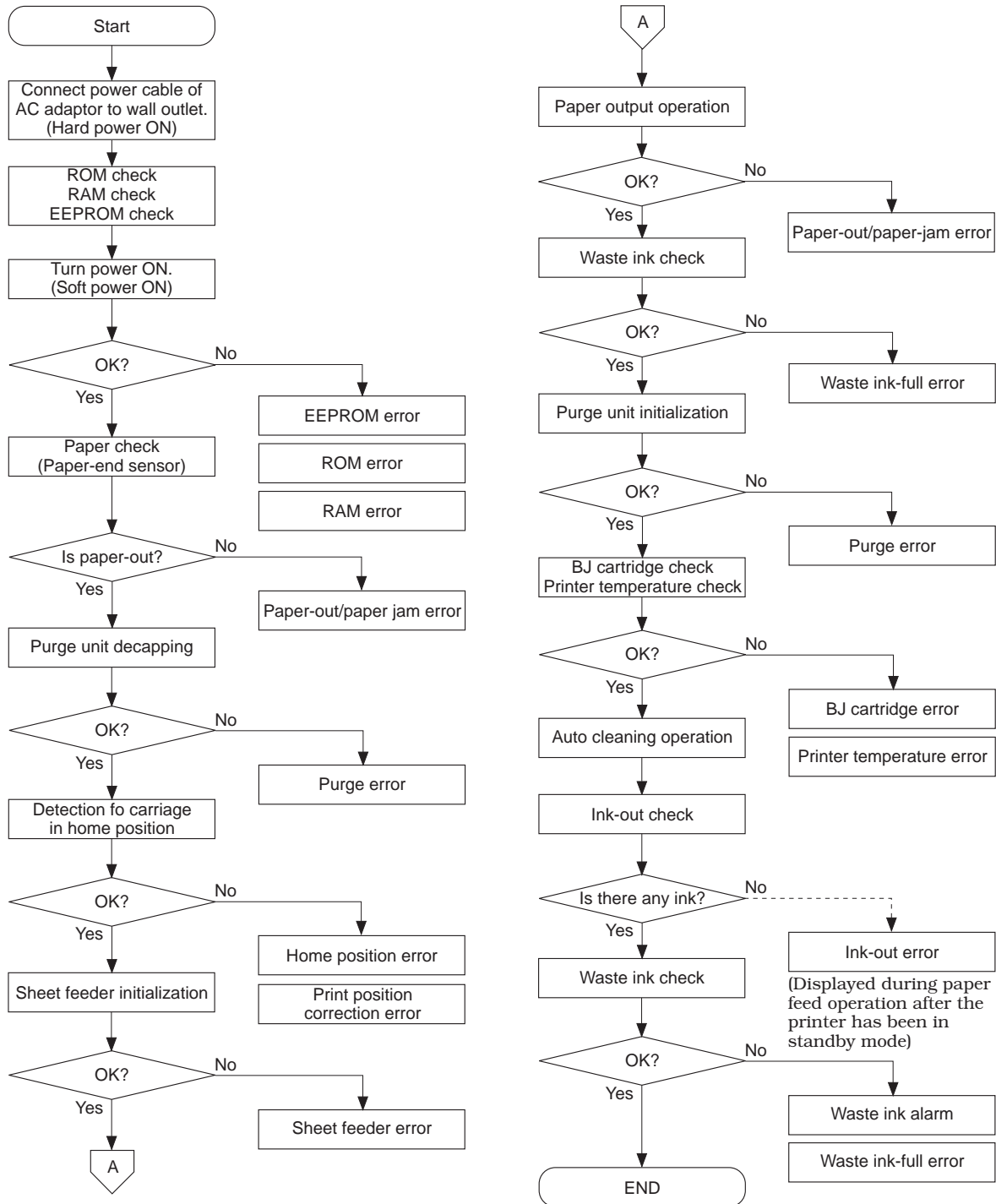

Figure 4-2 Flowchart of Initialization Sequence

### 1.3 Print Signal Sequence

The following describes the sequence of signals from the time the host PC sends the print signals to the printer up to the point at which printing is performed.

- a) The host PC sends print signals to the printer.  
The print signals consist of print data and control commands.
- b) The printer controller receives the print signals and temporarily stores them in the DRAM receive buffer.
- c) The MPU fetches the print signals from the receive buffer and separates the print data from the control commands based on the program in the control ROM.  
The MPU processes the control commands based on the program in the control ROM.
- d) The MPU expands the print data in the DRAM print buffer.
- e) The printer controller receives the request to start printing from the MPU and the print data is sent from the DRAM by DMA to the printer controller.
- f) The printer controller converts the print data into serial data for the respective BJ heads and outputs this data to the BJ heads with control signals.  
The drive circuits in the BJ heads convert the serial data to parallel format and control the output of inks onto the print paper as indicated by the control signals.
- g) The MPU and printer controller sense the status of the BJ heads and printer and control the printer as a whole, including the motor drivers, etc.

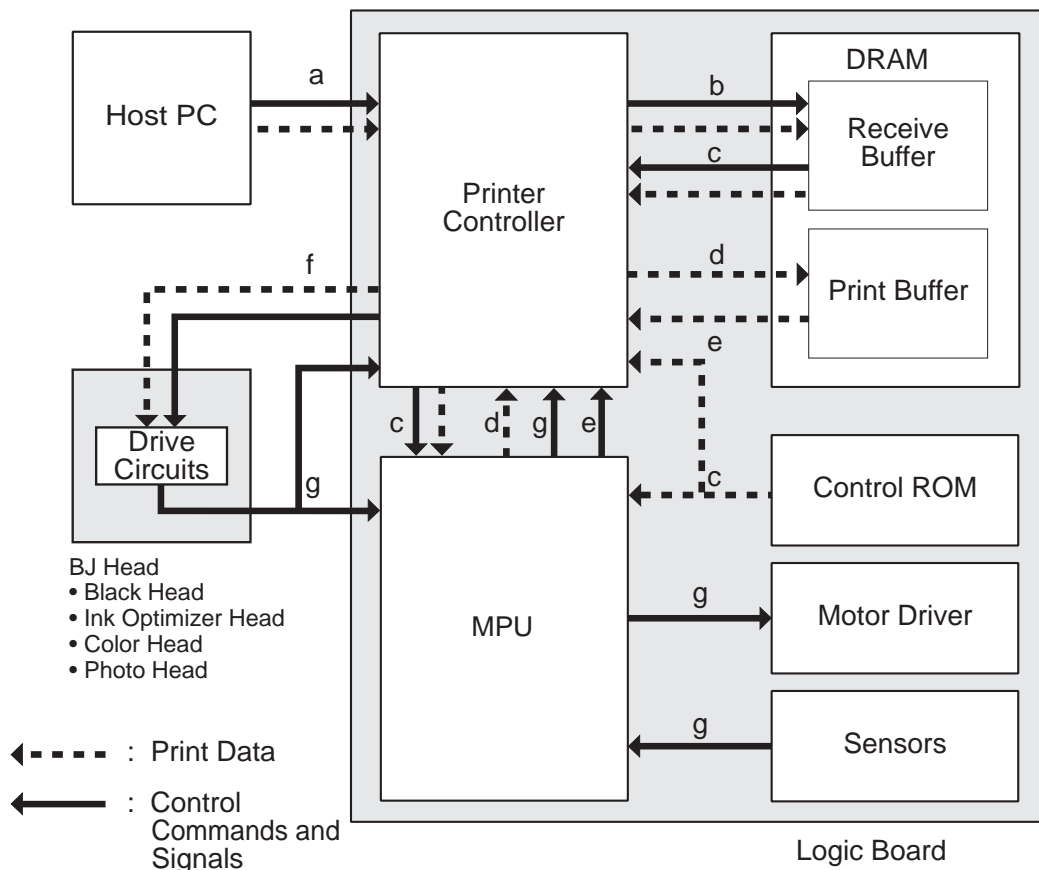

Figure 4-3 Print Signal Sequence



The BJC-7100 supports the Canon extended (native) mode, but not emulation. The print signals sent from the host PC are therefore Canon extended mode signals converted by the printer driver.

## 1.4 BJ Cartridge Drive

The BJ cartridges are driven according to the print data and control signals output by the logic board. The control signals determine the timing with which ink is ejected from the nozzles in the BJ heads and the amount of ink. These are optimized by the printer controller according to the conditions shown below. The control signals also stabilize the amount of ink by keeping the BJ heads at the optimum temperature.

The drive frequency is changed to 14.4kHz, 10.56kHz or 9.6kHz by print modes.

- BJ head temperature (heater board) and printer temperature
- Fluctuations in the heater characteristics of the BJ heads (head rank)
- Print mode and media being printed on

### 1.4.1 Print drive control

In the BJC-7100, printing is achieved by block dispersal drive, in which the three vertical rows of nozzles fire sequentially and driven alternately odd/even to minimize the concurrent firing of neighbouring nozzles.

The heat enable signal consists of a pre-pulse and main pulse. To keep the ink jetting in the optimum state, the pulse width is varied according to the internal state of the printer, such as the head rank, printer temperature, and head temperature.



---

The BJC-7100 uses a range of inks and, when printing on plain paper or envelopes in other than draft mode, an ink optimizer for plain paper. The ink optimizer is an almost colorless, transparent fluid.

For simplicity in this manual, we refer to the ink optimizer for plain paper simply as ink optimizer or just optimizer. We also refer to the various colored inks and the ink optimizer for plain paper simply as "inks".

---

### 1.5 Power-Off Sequence Flowchart

The following flowchart indicates the steps in the sequence between turning the printer power off by pressing the *POWER* button until the printer stops.

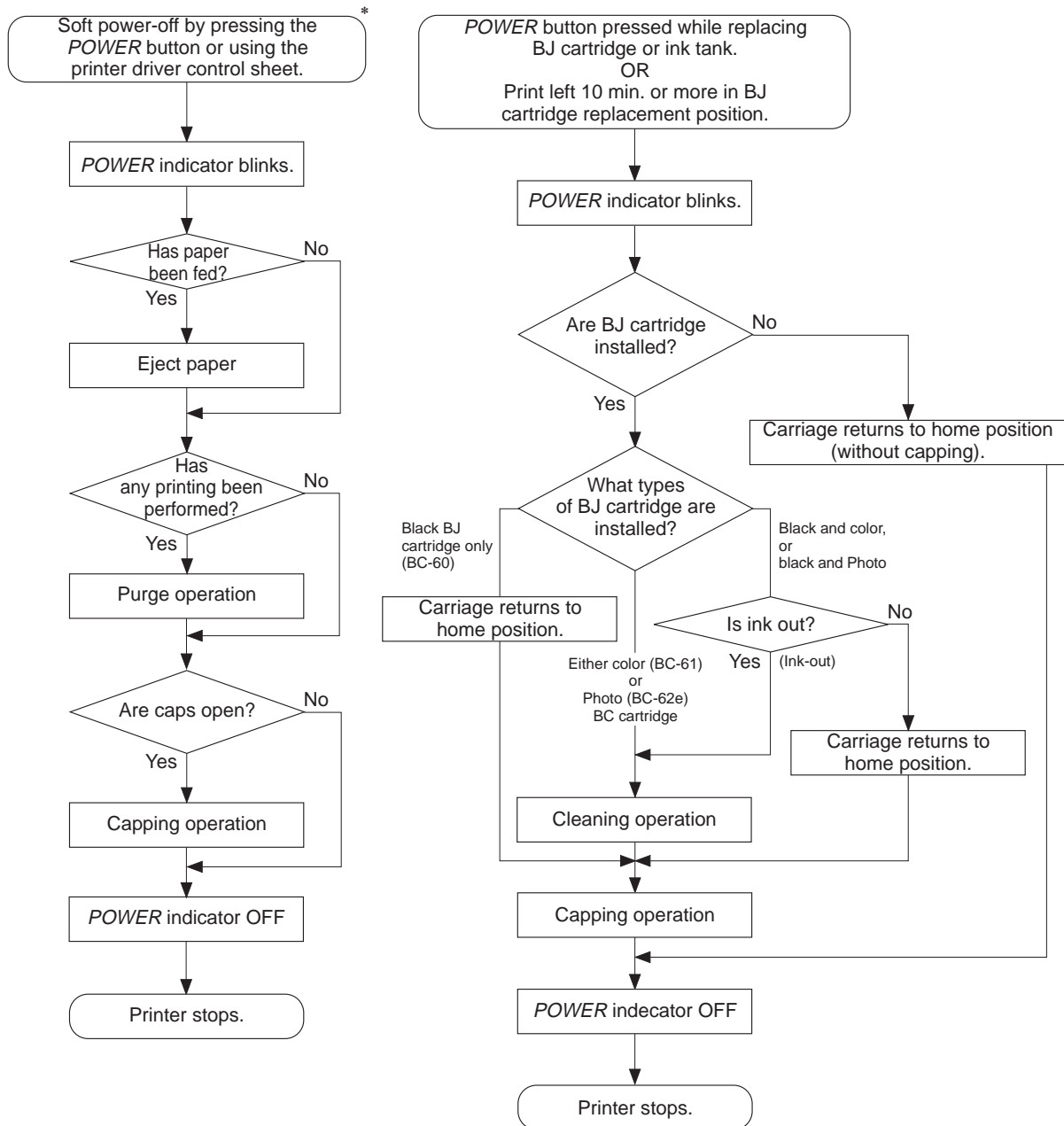

\* : If the power is turned off using the *POWER* button or the printer driver control sheet (soft power off) during cleaning or capping operations, this sequence starts on completion of that operation.

**Figure 4-4 Power-Off Sequence Flowchart**



If the power cord or AC adaptor is disconnected before the printer is turned off with the *POWER* button, the power-off sequence may be interrupted without the nozzles being capped. In this case, reconnect the power cord or AC adaptor, press the *POWER* button to start up the printer as normal, then turn off the printer with the *POWER* button before disconnecting the power cord or AC adaptor.

## 2. FIRMWARE

### 2.1 Interface

The printer is equipped with an IEEE1284-compatible bidirectional parallel interface. This interface supports compatible mode, nibble mode, and ECP mode.

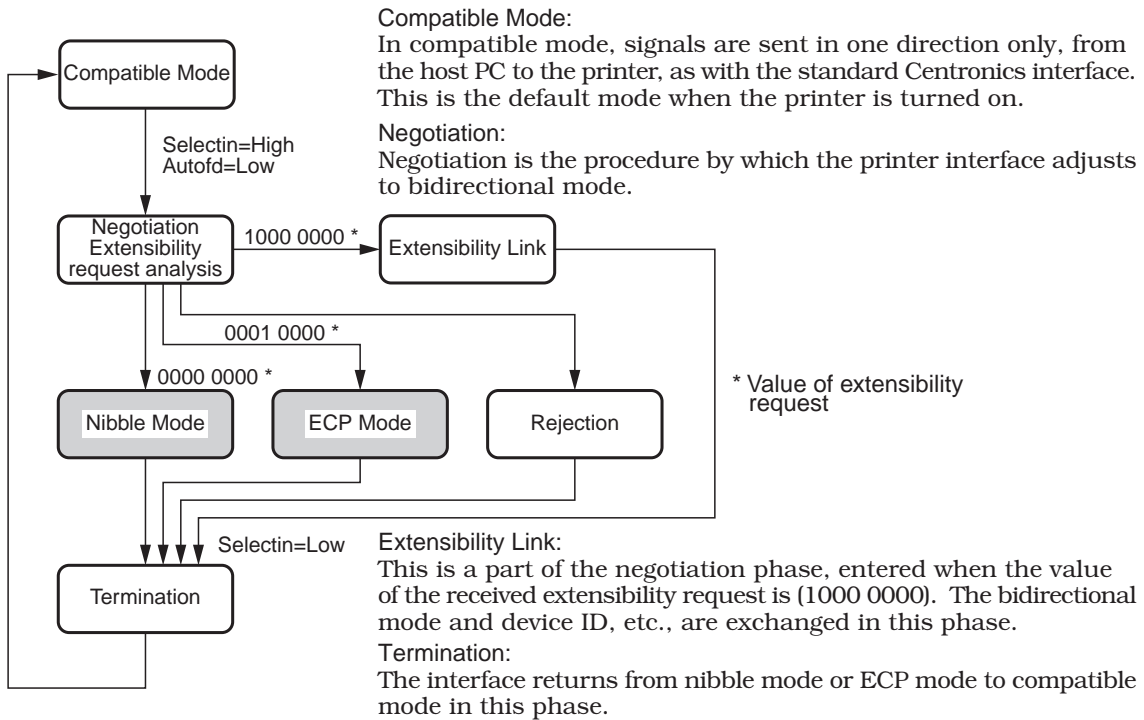

Figure 4-5 Bidirectional Centronics Specifications Selection Sequence

#### 2.1.1 Compatible mode

In compatible mode, the parallel interface sends data in 8-bit units. Data is sent using handshaking based on the  $\overline{\text{DATA STROBE}}$ ,  $\text{BUSY}$ , and  $\overline{\text{ACKNLG}}$  signals.

When data (Data 1 to 8) and the  $\overline{\text{DATA STROBE}}$  signal are input from the host PC, the printer controller, which controls the parallel interface, outputs a  $\text{BUSY}$  signal and latches the data signals as  $\overline{\text{DATA STROBE}}$  falls. After the  $\text{BUSY}$  signal has been output, the printer controller fetches the latched data via the DRAM bus to the receive buffer in the DRAM. After writing the data to the receive buffer in the DRAM, the printer controller outputs an  $\overline{\text{ACKNLG}}$  signal, sets the  $\text{BUSY}$  signal "Low", and waits to receive the next data from the host PC.

The BJC-7100 can reduce the response time by the operation in the printer driver. This achieves faster printing, however, this may not work with some host computers.

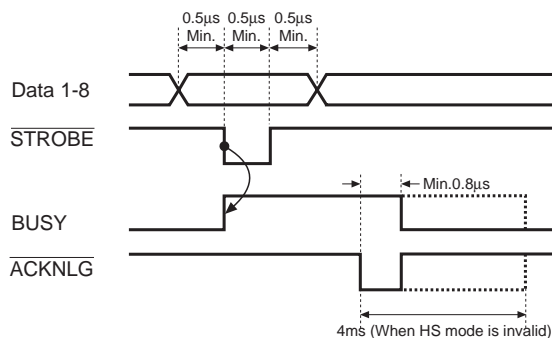

Figure 4-6 Interface Timing (Compatible Mode)

### 2.1.2 Nibble mode

In nibble mode, 8-bit data is sent from the printer to the host PC in two 4-bit blocks.

The printer lowers the DataAvail signal when it is ready to send data to the host PC. After confirming the fall in the HostBusy signal, the printer prepares 8 bits of data and outputs the low 4 bits on the control signal line on the fall in the PtrClk signal. When the PtrClk signal drops, the host PC fetches the data and raises the HostBusy and PtrClk signals.

Next, when the printer has confirmed the second drop in the HostBusy signal, it outputs the high 4 bits of data to the control signal line. If, after the HostBusy signal has risen, there is no more data to be sent to the host PC, the DataAvail signal rises and the printer enters a standby state until there is more data to be sent.

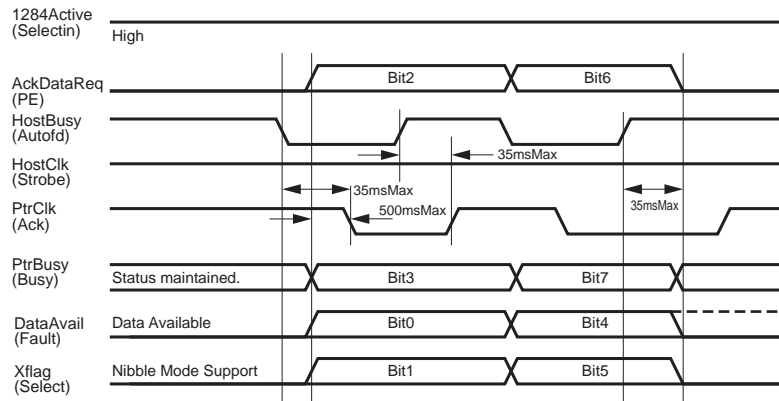

Figure 4-7 Interface Timing (Nibble Mode)

### 2.1.3 ECP mode

Because data is sent and received in both directions on the data bus in ECP mode, data can be received at high speed. Because control signals can be used to separate data from commands, and bidirectional communication can be established within this mode, there is no need to switch to other modes when switching the direction in which data is being sent.

The data bus switches direction from forward to reverse data transmission in response to a fall in the AckReverse (PE) signal from the printer.

The data bus switches direction from reverse to forward data transmission in response to a rise in the ReverseRequest (Init) signal.

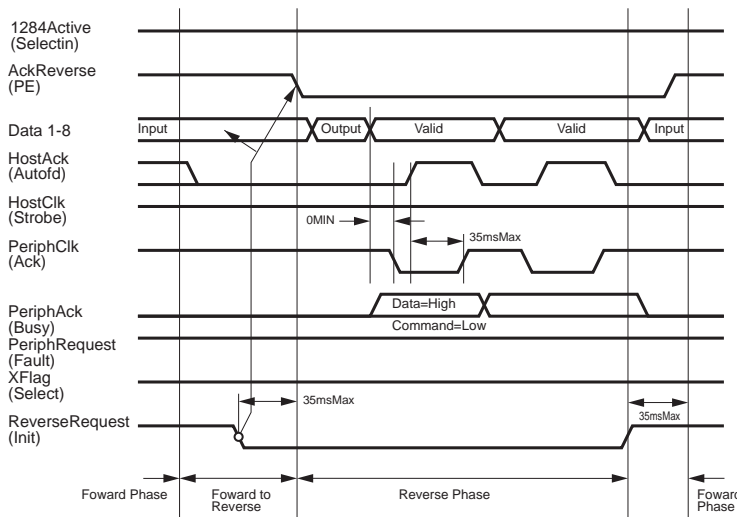

Figure 4-8 Interface Timing (ECP Mode)

### 2.2 Print Modes

The printer selects the carriage operation and bubblejet drive method on the basis of the media and print quality selected by the driver, and the print data that is received from the host PC. This enables the printer to achieve optimum print quality, free of smears and fragmentation.

To improve the quality of images, the printer is designed to print the data using multiple passes of the carriage.

By increasing the number of passes for the data as a whole, the time required for the ink for each piece of data to dry is split up, making ink smears less likely.

The printer selects the optimum print mode according to the type of BJ cartridge(s) installed, the ink system being used, and the various settings, such as print media and print quality, selected using the printer driver.

**TABLE 4-1 NUMBER OF PASSES VS NUMBER OF OPERATIONAL HEAD NOZZLES**

BJ Cartridge	Quality	Draft	Standard (HS)	Standard (HQ)	HQ	Fine
	Direction					
	Dithering	Bi-directional	Auto	Uni-directional		
Media	Fine(fast) / Fine / Auto			Diffusion (* Auto is selectable)		
Black + Photo	Plain Paper	300 x 300 dpi 1 p 24	600 x 600 dpi 1p 16 POP		300 x 300 dpi 3 p 17 POP	300 x 300 dpi 4 p 17 POP
	Transparency				300 x 300 dpi 3 p 17	300 x 300 dpi 4 p 17
	BPF					600 x 600 dpi 4 p 17
	Fabric sheet					300 x 300 dpi 3 p 16
	Glossy photo paper					
	Glossy photo film				600 x 600 dpi 3 p 17	600 x 600 dpi 4 p 17
	High Resolution paper					
Black + Color	Plain Paper	300 x 300 dpi 1 p 24	600 x 600 dpi 1 p 16 POP	300 x 300 dpi 3 p 17 POP	600 x 600 dpi 3 p 17 POP*	600 x 600 dpi 4+ p 17 POP
	Transparency			300 x 300 dpi 3 p 17	600 x 600 dpi 4 p 17	
	BPF					
	Fabric sheet			300 x 300 dpi 3 p 16		
	Glossy photo paper					
	Glossy photo film			600 x 600 dpi 3 p 17	600 x 600 dpi 4 p 17	
	High Resolution paper					600x1200 dpi 8 p 17

- 7-color (photo ink used) printing is carried out only for shaded in modes .  
4-color printing is used for all other modes. The ink optimizer is used only for items marked "POP."
- The number of passes is each mode and the paper feed amount per pass are as follows:  
 1P: During 1 pass printing/Bk printing only, 304 nozzles. Otherwise, 60 nozzles  
 3P: 3-pass printing/always 24 nozzles  
 4P: 4-pass printing/always 16 nozzles  
 8P: 8-pass printing/always 8 nozzles  
 4&3P: Bk 4-pass and color 3-pass printing/Bk printing only, 40 nozzles. Otherwise, 24 nozzles  
 4+P: 4-pass printing/24 nozzles and 16 nozzles alternately repeated
- Carriage Speed  
 24: 24 inch/sec  
 16: 16 inch/sec  
 17: 17.5 inch/sec
- The Black + Color mode is operable even if the photo BJ cartridge is attached on the printer.



### 2.2.1 Plain paper optimized printing mode (P-POP)

Only when you select plain paper (in other than draft mode) using the printer driver, the BJC-7100 ejects ink optimizer from the BC-60's ink optimizer head.

The printer jets the ink optimizer onto the plain paper, followed by the normal ink to minimize smearing and improve the ink's water resistance.

### 2.2.2 Economy print mode (Draft mode)

Economy print mode is the fastest print mode of the BJC-7100. Printing is performed in single passes in bidirectional mode. Because of the speed and bidirectional passes, no ink optimizer is used in this mode, which also cannot be selected when using the photo ink system. Because less ink is used in this mode, the printed image is lighter.

### 2.2.3 Standard mode

The standard mode is further divided into two modes, "speed priority mode" and "quality priority mode." The speed priority mode is suitable for printing text and simple illustrations, whereas the quality priority mode is suitable for printing originals that contain mainly images.

In the speed priority mode, the carriage makes a single pass per line at all times. This mode is basically unidirectional printing. When only black is being printed, the printing speed is improved by detecting parts of the original to be printed that do not contain print data on each horizontal line, and printing in both directions taking those lines as the threshold between unidirectional and bi-directional printing.

In the quality priority mode, the carriage makes three passes per line to print at higher quality. In this mode, the printing speed decreases, and photo ink cannot be used.

### 2.2.4 High quality and fine mode

Photo print mode uses the thinner inks of the Photo BJ cartridge (BC-62e Photo) to suppress granularity when printing images with multiple halftones and high contrast. By combining color and photo inks to achieve nine halftones, not only is the BJC-7100 able to print high-contrast images, but also the subtle differences in intermediate tones.

The photo inks are used in the low-density portions to minimize granularity.

600 × 1200 dpi (8pass) printing process achieves high quality printing without the photo inks.

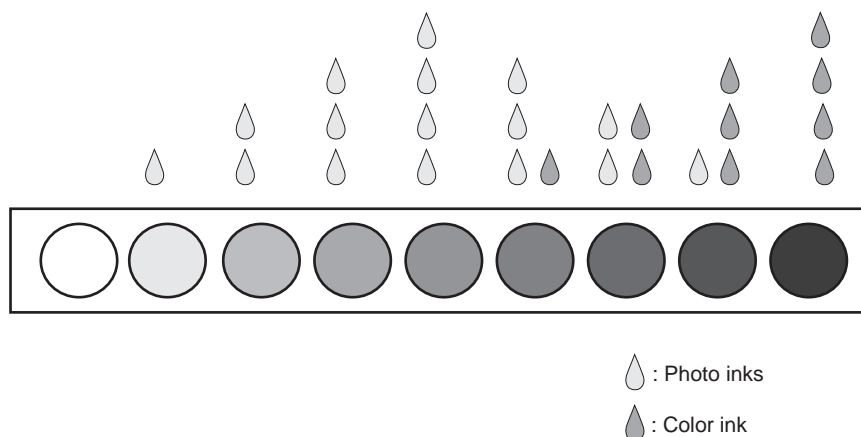

**Figure 4-9 Photo Print Mode (Image)**

### 2.2.5 Print mode settings

The following table shows the default print mode settings in the printer driver. Select the Print Mode parameters to change the settings.

**TABLE 4-2 MAIN DEFAULT PRINT MODE SETTINGS**

Print mode	Ink system	Dither settings	Print media	Ink optimizer	Print direction
Text	Color	Fine (fast)	Plain paper	Yes	Unidirectional
Super Photo	Photo color	Diffusion	High-resolution papers	No	Unidirectional
Auto	Color	Auto	Plain paper	Yes	Unidirectional
Draft	Color	Fine (fast)	Plain paper	No	Bidirectional
Photo	Color	Diffusion	High-resolution papers	No	Unidirectional
Graphics	Color	Diffusion	High-resolution papers	No	Unidirectional
Camera	Photo color	Diffusion	High-resolution papers	No	Unidirectional

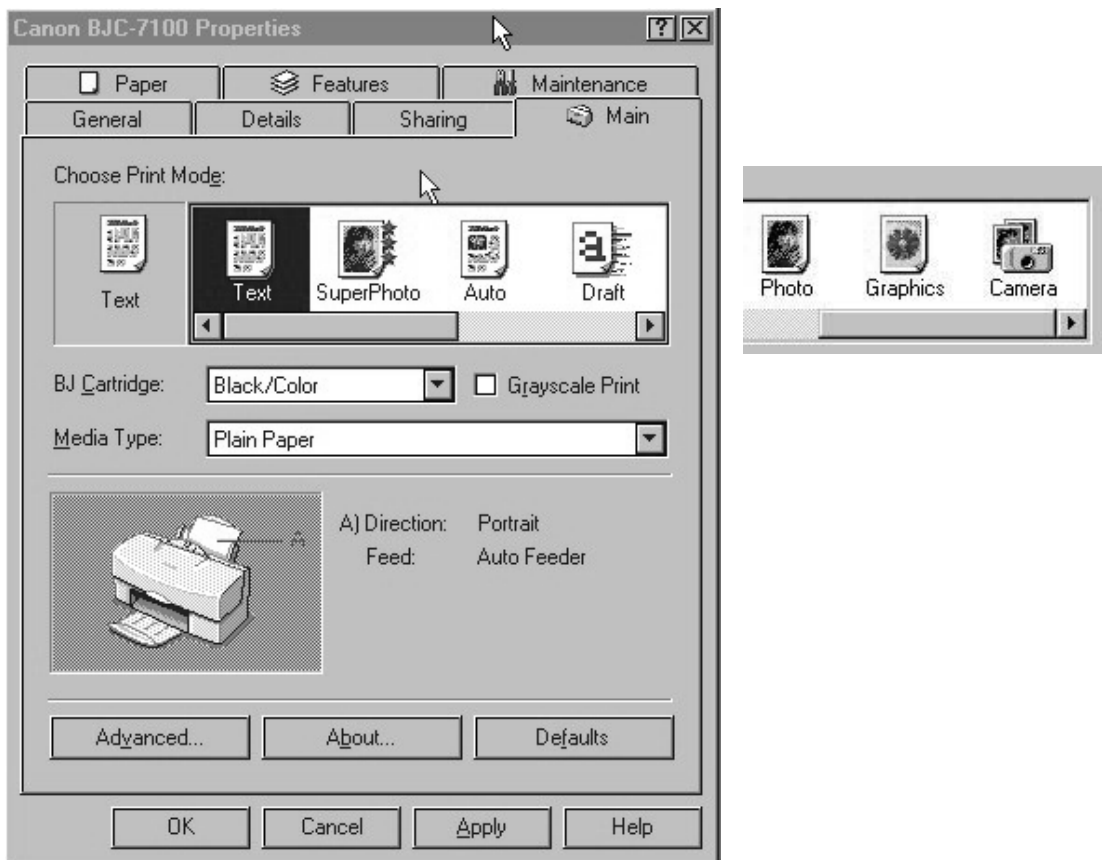

**Figure 4-10 Print Mode Main Sheet (Sample)**

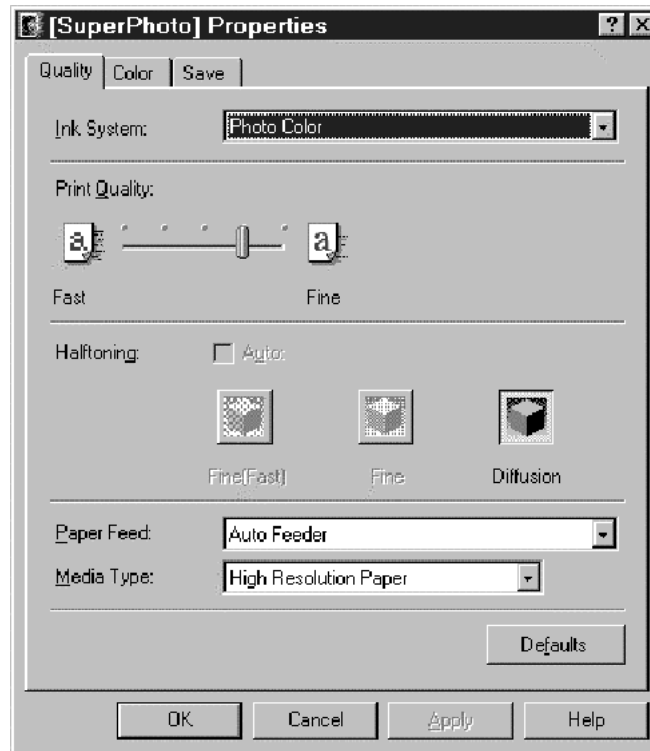

**Figure 4-11 Print Mode Detail Quality Sheet (Sample)**

## 2.3 Smoothing Function

The BJC-7100 has two methods of smoothing black print data.

The printer driver can convert  $600 \times 600$ dpi data into data equivalent to  $1200$ dpi (h)  $\times$   $600$ dpi (v). The printer itself can also convert  $300 \times 300$ dpi data into data equivalent to  $600 \times 600$ dpi.

## 2.4 Print Optimization Controls

### 2.4.1 Power monitor

When, due to high-duty printing, etc., the total head drive power exceeds the power supply capacity, the consumption is automatically reduced.

### 2.4.2 Head sticking prevention

To prevent ink mist dispersion caused by high-duty printing, a one pass-worth of data is splitted and printed as a 2 pass data.

### 2.4.3 Ink smear prevention

Printed pages ejected from the printer dry naturally in the paper output tray. If, before a page has dried, the next printed page is ejected onto it, there is a risk that the ink on the first page will be smeared.

When printing high-density images, etc., the BJC-7100 pauses the carriage between printing scans and/or delays the ejection of the printed page, to prevent smearing.

## 2.5 Head Overheat Protection

If the temperature of the print heads of the BJ cartridges is allowed to rise beyond a set temperature, not only is there a risk of burns in the event that the heads are touched, but it becomes increasingly difficult to achieve optimum print quality. The printer is therefore equipped with an overheat protection function that uses thermal sensors in the heads to prevent the temperature rising above the set temperature.

Print head temperature detection is effected by independent sensors in the black head, optimizer head, color head, and photo head.

### Protection level 1:

This protection level prevents the operator from touching the metal plate of a hot print head when changing the BJ cartridge. If, when replacing a head, the head temperature is higher than the temperature at which replacement is prevented, the printer displays a BJ cartridge overheat warning (and the beeper sounds 4 times). While the protection function is operating, the printer temporarily will not allow BJ cartridge or ink tank replacement.

### Protection level 2:

The carriage returns to the home position after printing each line and waits for a maximum of 3 seconds to allow the print head to cool. This overheat protection mechanism continues for a minimum of 20 seconds.

### Protection level 3:

If the head temperature continues to rise, the printer stops printing; the carriage continues to move and the paper is fed through the printer. The printer then discards any further data sent from the host PC, and performs cleaning operations, ink-out detection, and checks for failure of the head temperature sensor. If the printer determines that the ink or ink optimizer has run out, it displays an ink-out error when data is next received from the host PC. If the head temperature sensor is found to be faulty, the printer displays a BJ cartridge overheat error.



---

If the BJ cartridge head temperature sensor is faulty, the above overheat protection controls may not function correctly.

If it detects a fault in the head temperature sensor, the BJC-7100 printer displays other hardware error messages (the head temperature sensor error message may not be displayed correctly).

If the printer cannot recover from the overheat protection control operations to normal printing, or if other hardware error messages are displayed, replace the BJ cartridge. For details of how to recover from the respective error states, see *Part 5, Section 6, "TROUBLESHOOTING"* (page 5-13).

---

### 3. PRINTER'S MECHANICAL SYSTEM

#### 3.1 Overview

This section provides an overview of the printer's mechanical system.

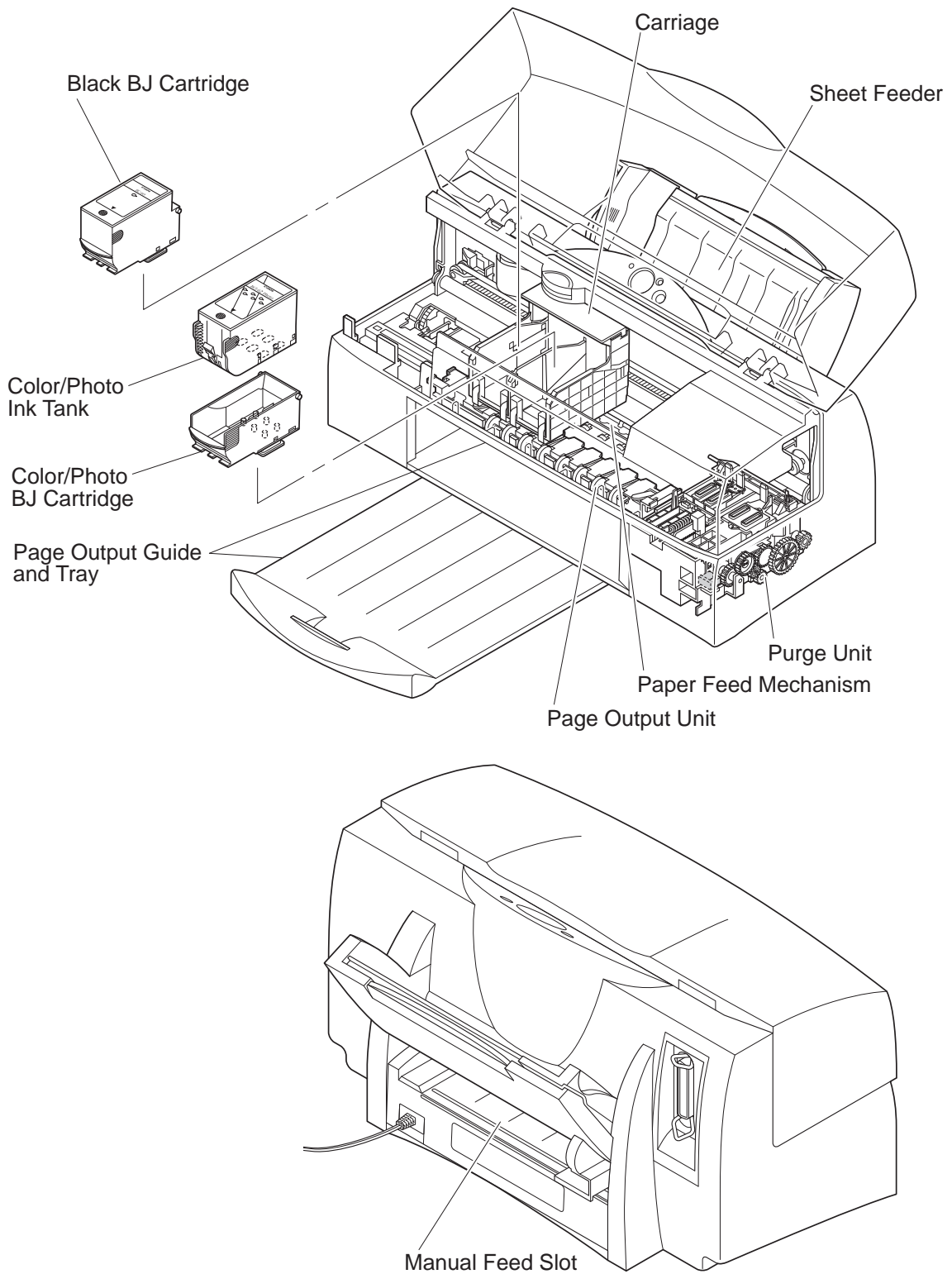

Figure 4-12 Printer's Mechanical System

### 3.1.1 Structure of printer's mechanical system

#### 1) BJ Cartridge/Ink Tank

The printer is shipped with the BC-60 BJ cartridge, which contains black ink and ink optimizer, and the BC-62e Photo BJ cartridge, which contains three color inks and three photo inks. The BC-61 color BJ cartridge which contains three color inks may be shipped instead of the BC-62e Photo.

The BC-60 has a unified print head and ink tank, while the BC-62e Photo has separate head and ink tanks that can be replaced.

The user can decide whether to use the combination of BC-60 and BC-62e Photo or BC-60 and BC-61 according to the type of data being printed.

#### 2) Purge Unit

To ensure high-quality printing, the purge unit, which is driven by the paper feed motor, caps and wipes the face of the BJ cartridge print head to make sure that the ink can be ejected cleanly from the nozzles when printing.

Functionally, the purge unit consists of a pump and wiper.

The pump draws ink from the BJ cartridge and removes the ink from inside the cap.

The wiper wipes the face of the head. When not printing, the nozzles of the BJ cartridge are capped to protect them.

#### 3) Carriage

The carriage travels horizontally across the print paper driven via the carriage belt by the carriage motor. Print signals output by the logic board are sent via the carriage ribbon cable to the two BJ cartridges mounted on the carriage.

The wiping hook on the bottom of the carriage trips the latch lever and wiper lever so that the ink optimizer head is wiped.

By controlling the position of the slide lock lever of the purge unit, the carriage switches between paper feed/sheet feed drive and purge unit drive.

#### 4) Paper Feed/Sheet Feeder

The built-in sheet feeder is driven by the paper feed motor and transports the print paper to the paper feeder.

The paper feed, which is driven by the paper feed motor, rotates the feed rollers so that the print paper is transported vertically.

#### 5) Paper Output

The paper output unit prevents smearing and dirtying by ink by providing a time interval up to when the paper being printed is stacked on top of the already printed paper on the output tray. This unit feeds printed print paper to the output tray as each sheet is printed.

Print paper is fed to the output tray by the power of the paper feed roller. This power is transferred via the paper feed roller gear to the paper output roller inside the paper output unit to rotate the paper output roller.

Paper end guides are located at both ends of the paper passage path in the paper output unit. When the paper is being output, both ends of the print paper are lifted up to slightly warp the paper, and the leading edge of the print paper being printed is made to hang down so that it does not contact the already printed paper on the output tray.

#### 6) Manual Feed Slot

Paper can be fed into the printer manually from the manual feed slot on the back.

Paper fed manually into the printer takes precedence over any print paper already in the sheet feeder.

## 3.2 BJ Cartridge

### 3.2.1 BJ cartridge structure

#### 1) BC-60

In the BC-60, the BJ head is unified with the ink tank.

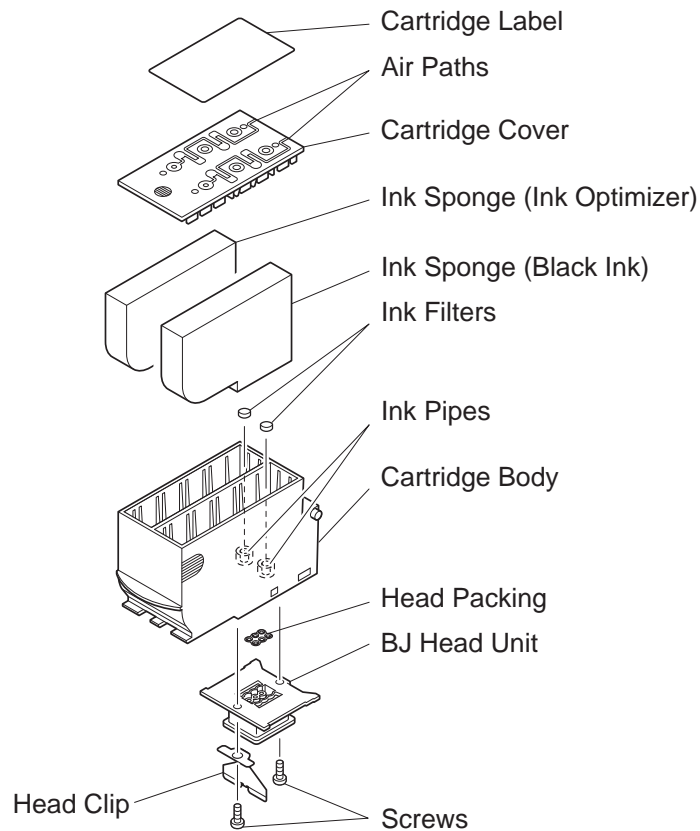

**Figure 4-13 Structure of BC-60**

#### **Cartridge body**

The cartridge body houses the ink sponges and is the base for the BJ head unit.

#### **Ink sponges**

The two ink sponges hold the ink and ink optimizer that are fed to the BJ head unit.

#### **Ink pipes**

The ink pipes transport the ink from the ink sponges to the BJ head unit.

#### **Cartridge cover**

The cartridge cover is welded to the cartridge body to prevent inks leaking from the body.

#### **Air paths/Cartridge label**

Air vents or paths are created between the inside and outside of the BJ cartridge through the holes and grooves in the cover and the label that is applied to it. The air vents prevent pressure fluctuations inside the BJ cartridge due to ink consumption and atmospheric conditions, and help stabilize the supply of inks to the print head.

#### **Ink filters**

The inks are filtered to prevent foreign objects getting into the ink paths.

**BJ head unit**

The BJ head unit receives the ink from the ink pipes and ejects the ink at the print media according to the print signals from the signal contacts.

**Head clip/Screws**

The BJ head unit is fastened to the cartridge body using head clip and screws.

**Head packing**

The head packing ensures that the ink pipes and BJ head unit are in close contact to prevent ink leaking.

**2) BC-61 and BC-62e Photo**

The BC-61 and BC-62e Photo consist of a main unit made up of the BJ head unit mounted on the BJ cartridge body plus the ink tank, which can be removed and replaced.

**BC-61**

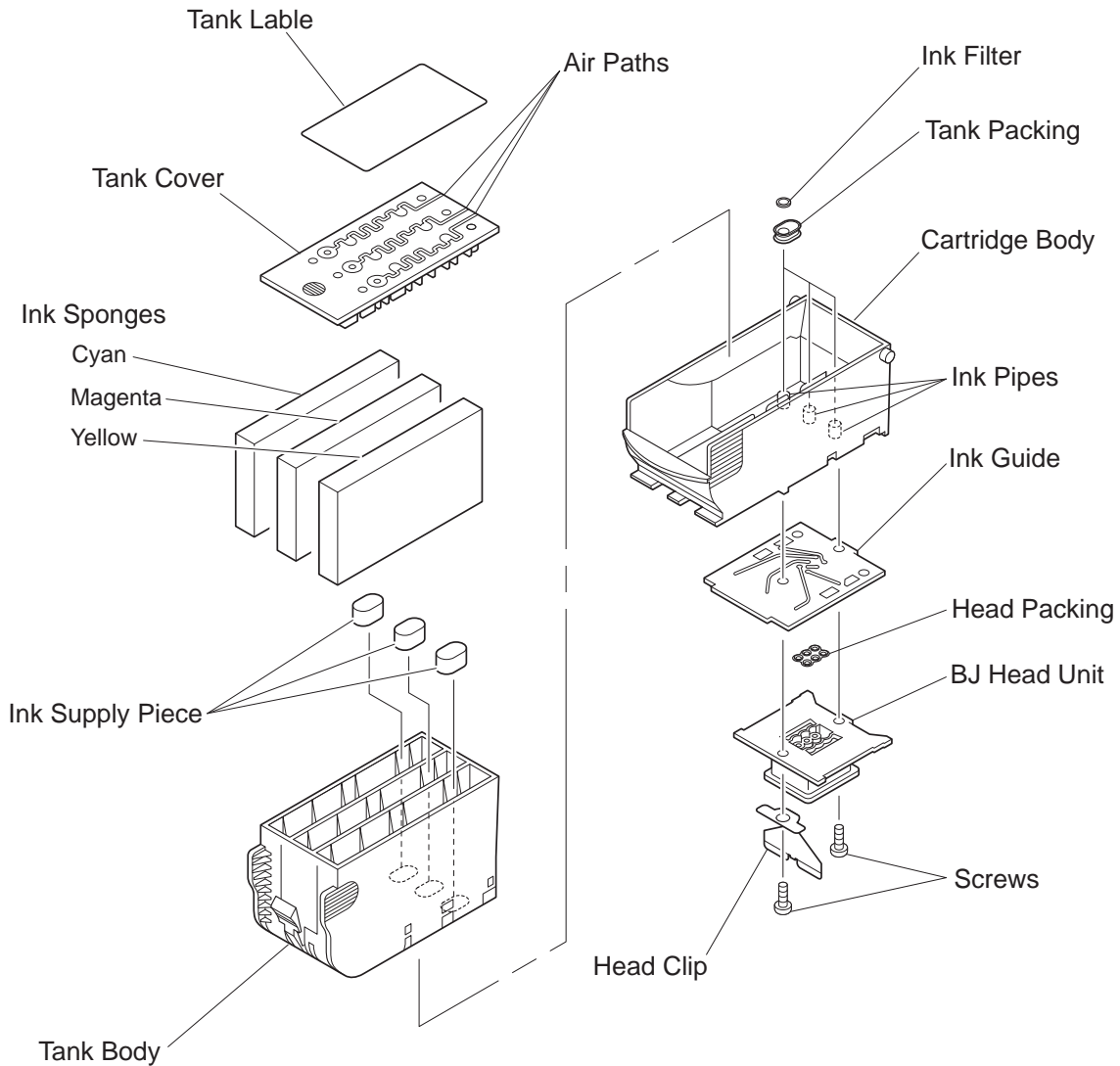

**Figure 4-14 Structure of BC-61**



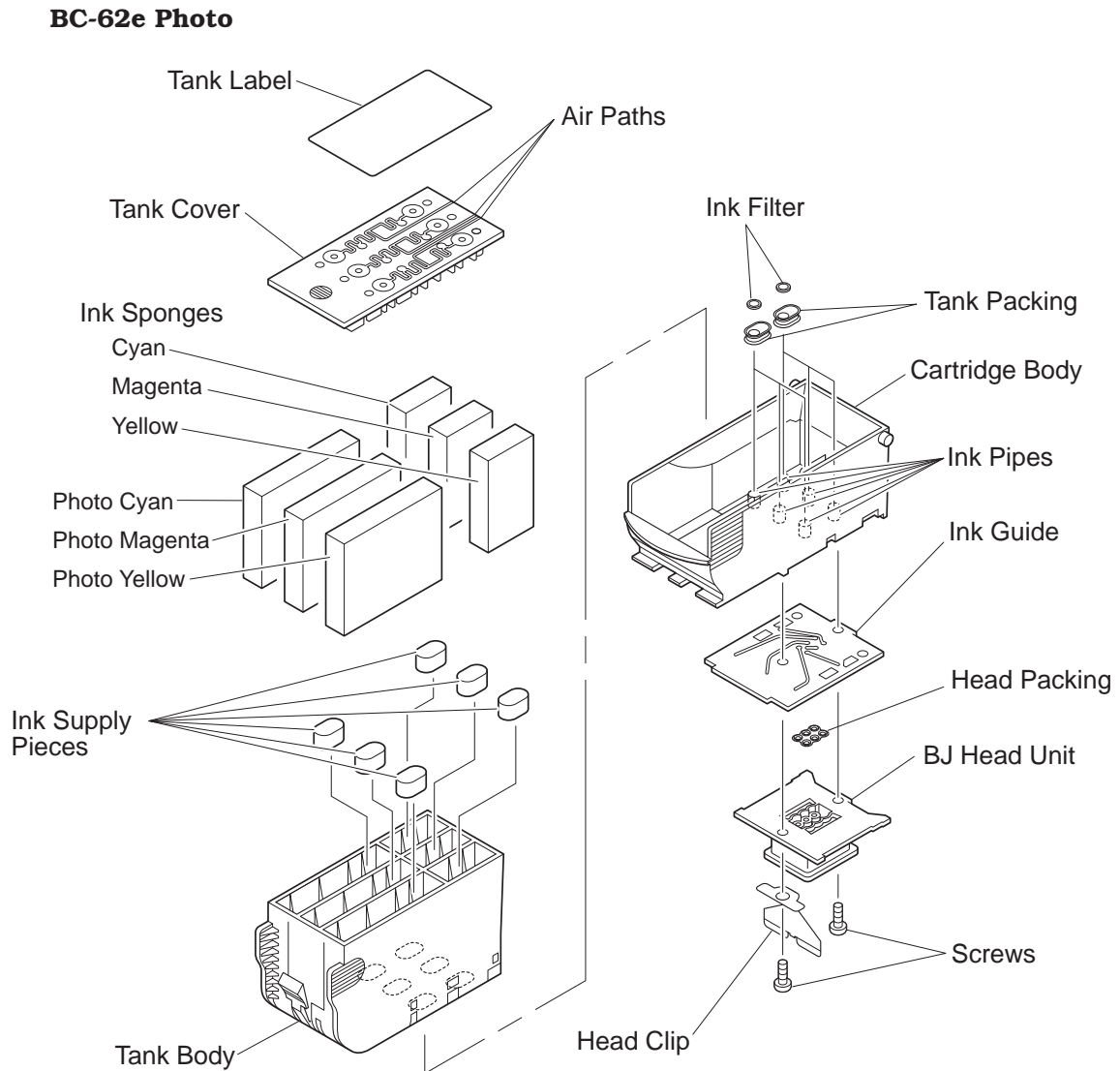

**Figure 4-15 Structure of BC-62e Photo**

#### **Tank body**

The tank body houses the ink sponges.

#### **Ink sponges**

The ink sponges hold the inks that are fed to the BJ head unit.

The BC-61 has three sponges for yellow, magenta, and cyan color inks. The BC-62e has six sponges for yellow, magenta, and cyan color inks, and yellow, magenta, and cyan photo inks.

#### **Ink supply pieces**

The ink supply pieces lead the ink from the ink sponges to the ink pipes.

#### **Tank cover**

The tank cover is welded to the tank body to prevent inks leaking from the body.

#### **Cartridge body**

The cartridge body is the base for the BJ head unit, from which it is separated by the ink guide.

**Air paths/Tank label**

Air vents or paths are created between the inside and outside of the BJ cartridge through the holes and grooves in the cover and the label that is applied to it. The air vents prevent pressure fluctuations inside the BJ cartridge due to ink consumption and atmospheric conditions, and help stabilize the supply of inks to the print head.

**Ink pipes**

The ink pipes transport the ink between the ink tank and ink guides.

**Ink filters**

The inks are filtered to prevent foreign objects from getting into the ink paths.

**Tank packing**

The tank packing ensures that the ink tank and ink pipes are in close contact to prevent ink leakage.

**BJ head unit**

The BJ head unit receives the ink from the ink guides and ejects the ink at the print media according to the print signals from the signal contacts.

**Head clip/Screws**

The BJ head unit is fastened to the cartridge body using head clip and screws.

**Ink guides**

These form the ink path between the ink pipes and BJ head unit.

**Head packing**

The head packing ensures that the ink guides and BJ head unit are in close contact to prevent ink leaking.

### 3.2.2 Structure of BJ head unit

The structure of the BJ head unit is different for each type of BJ cartridge.

#### 1) BC-60

The BC-60 has two identical print heads, each with 310 nozzles, mounted side by side. One head ejects black ink, while the other ejects the ink optimizer.

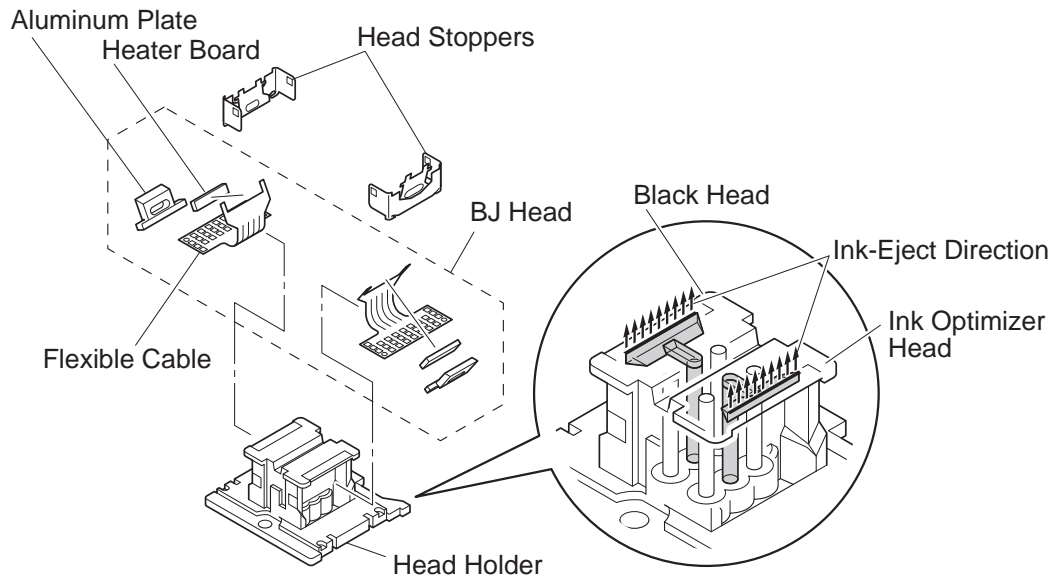

Figure 4-16 Structure of BC-60 BJ Head Unit

#### 2) BC-61 and BC-62e Photo

The BC-61 print head has 240 nozzles, which eject color inks.

The BC-62e Photo has two print heads, each the same as the BC-61 print head, mounted side by side. One ejects color inks while the other ejects photo inks.

#### BC-61

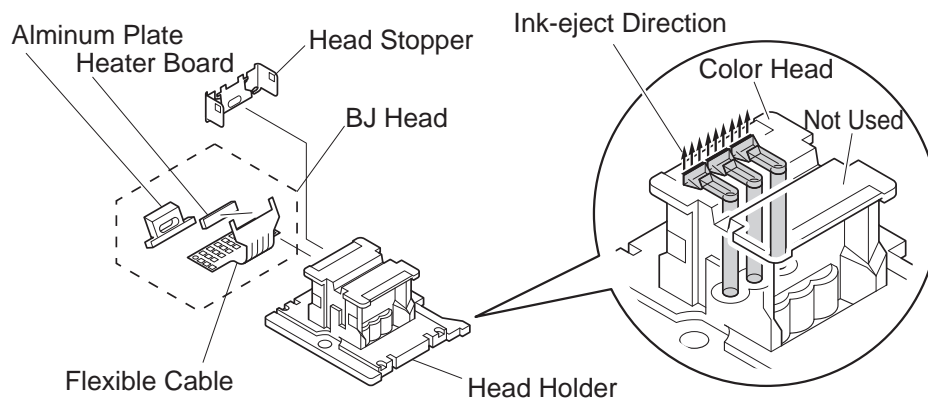
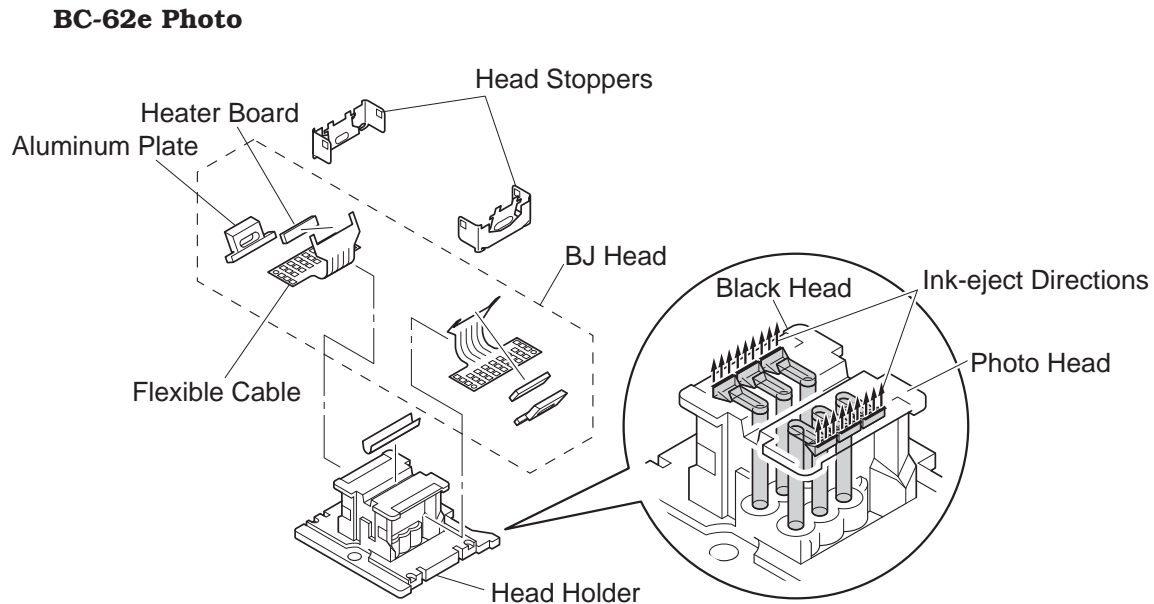

Figure 4-17 Structure of BC-61 BJ Head Unit



**Figure 4-18 Structure of BC-62e Photo BJ Head Unit**

### 3) Description of parts

#### **BJ Print Head (black head, ink optimizer head, color head, and photo head)**

The heater board and aluminum plate are connected to the flexible cable.

#### **Flexible Cable**

The signal contacts are connected to the heater board by printed pattern wiring. The contacts are in contact with the signal contacts on the carriage, and are used for the input and output of print signals and sensor signals between the printer and BJ print head (heater board).

#### **Heater Board**

The heater board has a built-in drive circuit, and is set against the ink room of the head holder and the nozzles.

The electrode for the ink-out detector is located at the ink room.

The heater is aligned with the rows of nozzles against the nozzles.

#### **Aluminum Plate**

The aluminum plate supports the heater board and flexible cable.

#### **Head Holder**

The head holder supports the BJ print head.

The ink room stores the inks that are supplied to the nozzles. The ink-out detection pulse is applied from the heater board electrode.

The nozzles are formed by aligning the ink ejection grooves with the heater array on the heater board.

#### **Head Stopper**

The head stopper attaches the BJ print head to the head holder.



The heater board uses semiconductor technology, in which the heaters and ICs, etc., of the drive circuit are mounted on a silicon plate. When the heater drive starts, the ink in the nozzles gets hot, causing the formation of many bubbles. These finally form one bubble which, as it heats up, forces the ink to be ejected from the nozzle. Even when the heater is stopped, the residual heat causes bubbles to continue to form and ink to be ejected from the nozzle tips. The nozzle is replenished with ink after the ink has been ejected.

### 3.2.3 Nozzle arrays

In each of the BJ print heads, the nozzles are arranged in vertical rows at a pitch of 1/600-in.

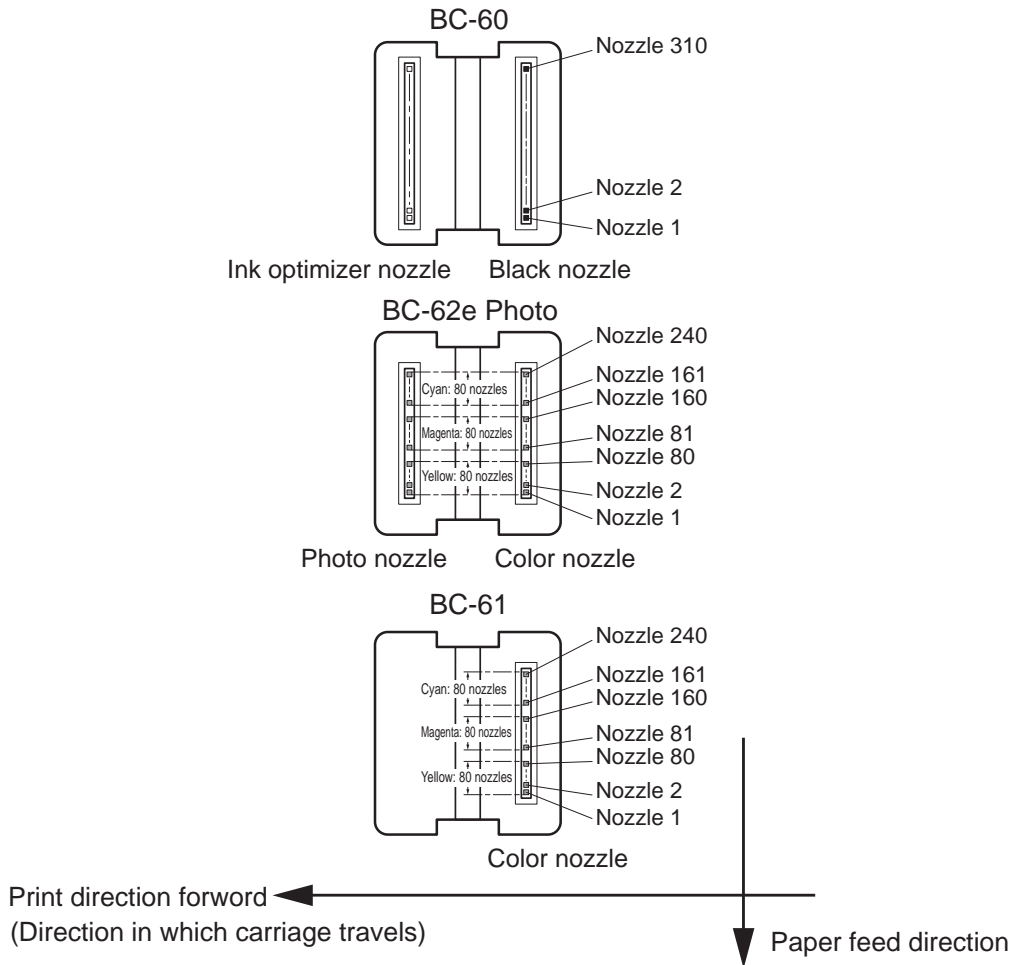

**Figure 4-19 Nozzle Arrays**



In addition to the nozzles shown in Figure 4-19, all BJ print heads have dummy nozzles at the top and bottom edges.

Also, the color head and photo head have 16 nozzles separating each color, and designed to prevent neighboring colors mixing. The dummy nozzles and color separation nozzles are not used for printing.

In the black head and ink optimizer head, up to 304 nozzles are used for printing.

Nozzles 1 to 3 and 308 to 310 are for adjusting the print head alignment (between the color head and photo head). According to the alignment value, the 304 nozzles actually used in printing may shift up or down within this range of 6 nozzles.

Because the black head and ink optimizer head, and the color head and photo head, are arranged symmetrically around a center point, the nozzle arrays are reversed.



For details of alignment, see Part 3, section 1.3.3, "Installing the BJ cartridge" step 3) "Aligning the print heads" (page 3-5).

### 3.2.4 Signal contacts

The signal contacts on the flexible cable are in contact with the signal contacts on the carriage, and are used to input and output print signals and sensor signals between the printer and BJ print head (heater board).

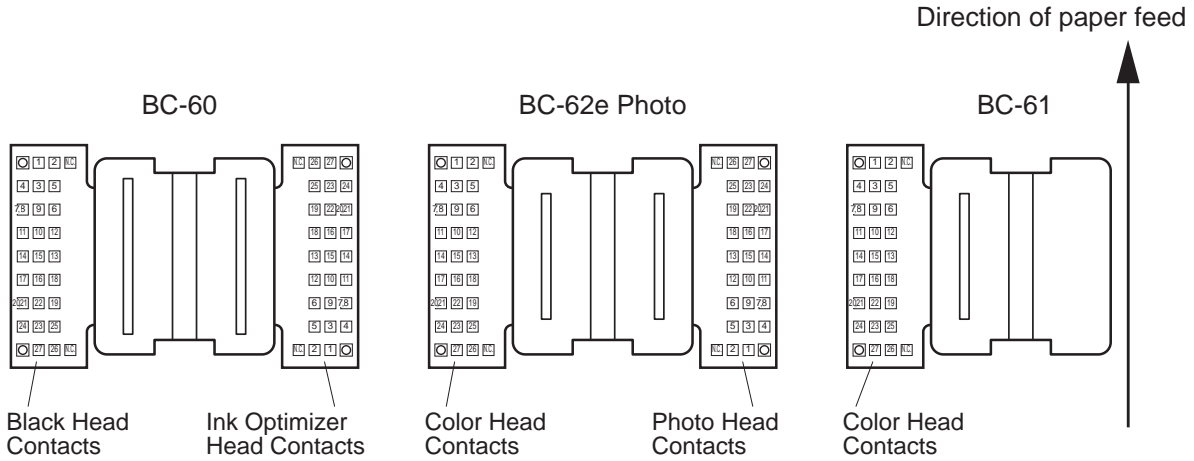

**Figure 4-20 Signal Contacts**

Table 4-4 shows the signals input and output by each print head.

**TABLE 4-3 BJ HEAD INPUT AND OUTPUT SIGNALS**

Pin No.	BJ print head*	Signal	IN/OUT	Function
1	ALL	VH	IN	Head drive voltage (20.0VDC ±0.3V)
2	OM	TSAOM	IN	Temperature sensor (diode) drive voltage
	BK	TSABK	IN	
	PH	TSAPH	IN	
	CL	TSACL	IN	
3	OM	ID2OM	OUT	Index 2 detection
	BK	ID2BK	OUT	Index 2 detection
	PH	ID2PH/ELYPH	OUT/IN	Index 2 detection/yellow ink-out detection pulse
	CL	ID2CL/ELCCL	OUT/IN	Index 2 detection/cyan ink-out detection pulse
4	OM	SUBHOM	IN	Heater drive
	BK	SUBHBK	IN	
	PH	SUBHPH	IN	
	CL	SUBHCL	IN	
5	OM	ID1OM	OUT	Index 1 detection
	BK	ID1BK	OUT	Index 1 detection
	PH	ID1PH/ELMPH	OUT/IN	Index 1 detection/magenta ink-out detection pulse
	CL	ID1CL/ELMCL	OUT/IN	Index 1 detection/magenta ink-out detection pulse
6	ALL	VDDH	IN	Head logic drive voltage

Pin No.	BJ print head	Signal	IN/OUT	Function
7,8	ALL	GND	...	GND
9	OM	HEATEOM	IN	Heat enable
	BK	HEATEBK	IN	
	PH	HEATEPH	IN	
	CL	HEATECL	IN	
10	OM	INVOM	IN	Inversion of output sequence of print data lock output signal, black and color heads locked OFF, ink optimizer head and photo head locked ON.
	BK	INVBK	IN	
	PH	INVPH	IN	
	CL	INVCL	IN	
11	ALL	ODDE	IN	Heat enable for odd black head and color head nozzles and even ink optimizer and photo head nozzles.
12	ALL	EVENE	IN	Heat enable for even black head and color head nozzles and odd ink optimizer and photo head nozzles.
13	ALL	BE0	IN	Generation of print data block output signal 1
14	ALL	VH	IN	Head drive voltage (20.0VDC $\pm$ 0.3V)
15	ALL	BE1	IN	Generation of print data block output signal 2
16	OM	IDATAOM	IN	Print data
	BK	IDATABK	IN	
	PH	IDATAPH	IN	
	CL	IDATACL	IN	
17	ALL	BE2	IN	Generation of print data block output signal 3
18	ALL	DCLK	IN	Print data transmission clock
19-21	ALL	GND	...	GND
22	ALL	LTCLK	IN	Specification of print data latch timing
23	OM	ELOM	IN	Optimizer-out detection pulse
	BK	ELBK	IN	Black ink-out detection pulse
	PH	ELCPH	IN	Cyan ink-out detection pulse
	CL	ELYCL	IN	Yellow ink-out detection pulse
24	OM	RANKOM	OUT	Rank resistance detection
	BK	RANKBK	OUT	
	PH	RANKPH	OUT	
	CL	RANKCL	OUT	
25	ALL	LTRST	IN	Latch reset
26	OM	TSKOM	OUT	Temperature sensor (diode) output voltage
	BK	TSKBK	OUT	
	PH	TSKPH	OUT	
	CL	TSKCL	OUT	
27	ALL	VH	IN	Head drive voltage (20.0VDC $\pm$ 0.3V)

\*: Symbols in the BJ print head columns are as follows:

ALL: Signals input to all heads

OM: IO signals for ink optimizer head only

BK: IO signals for black head only

PH: IO signals for photo head only

CL: IO signals for color head only

### 3.2.5 Drive circuit

The drive circuit built into the heater board controls the ejection of inks. The drive circuit differs according to the type of BJ cartridge.

#### 1) BC-60

The black head and ink optimizer head are each equipped with the drive circuit shown in Figure 4-21.

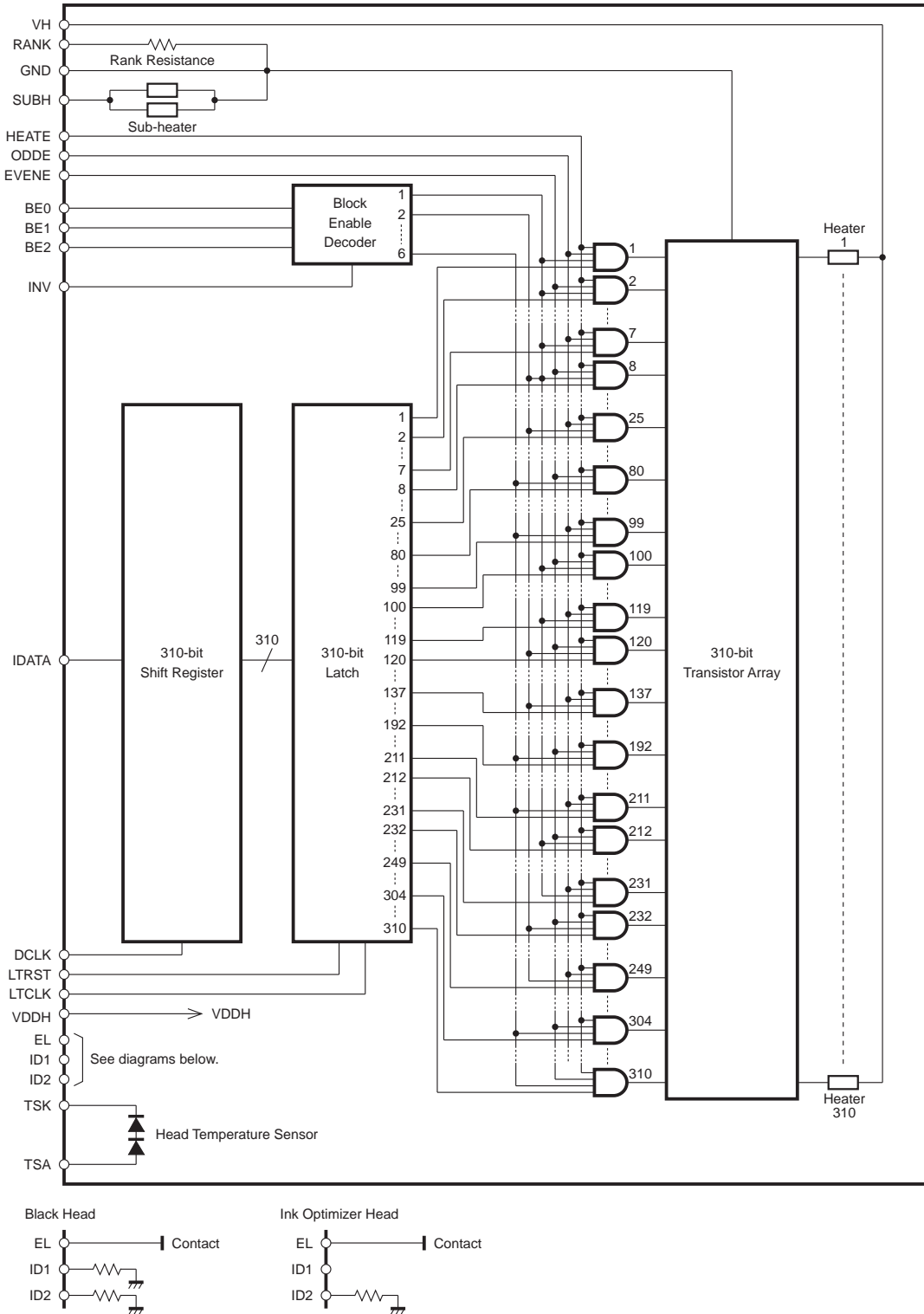
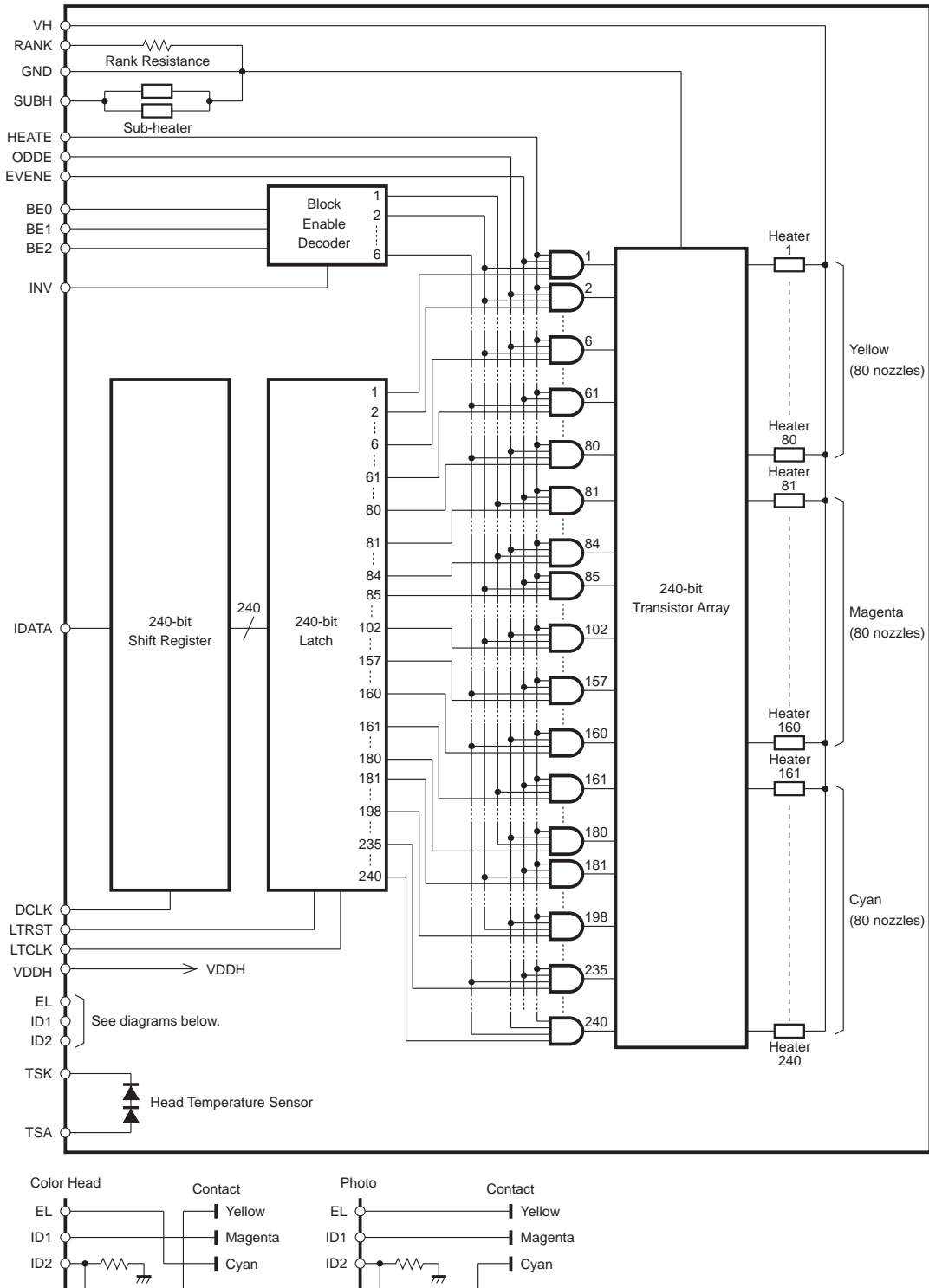

Figure 4-21 Block Diagram of BC-60 Drive Circuit



**2) BC-61 and BC-62e Photo**

The color head and photo head are equipped with the drive circuit shown in Figure 4-22.



**Figure 4-22 Block Diagram of BC-61/BC-62e Photo Drive Circuit**

### 3) Description of block diagram

#### **Block enable decoder** \*1

Generates BLOCK1 to 6 according to BE0 to 2 from the logic board.

The output sequence of BLOCK1 to 6 is inverted according to whether INV is High or Low.

#### **310-/240-bit shift register**

Converts IDATA \*1 from the logic board into parallel print data for output.

#### **310-/240-bit latch**

Latches and outputs the parallel print data using the LTCLK timing.

#### **AND gate** \*1

Outputs the part of the parallel print data specified by BLOCK1 to 6, EVENE, and ODDE.

#### **310-/240-bit transistor array** \*1

Turns on the heaters according to the print data from the AND gate.

The heaters, which are pulled up to VH, are turned ON by setting the heater connection Low.

#### **Heaters 1 to 310, or 1 to 240**

The heater temperature rises when turned on to pre-heat and main-heats the nozzles.

The heaters are aligned with the nozzle array against the nozzles in the head holder.

#### **Rank resistance**

Differences in the heater characteristics of the various BJ heads are ranked and marked using their resistance, which is detected by the printer. The resistance is read by the A/D board of the MPU as a voltage and converted to digital format to detect the rank, allowing the BJ print heads to be controlled for optimum print quality.

#### **Sub-heater**

This heater adjusts the temperature of the heater board to stabilize the ejection of inks. The printer drives the sub-heater according to the temperatures detected by the head temperature sensor and printer temperature sensor, which is mounted on the carriage board, and the print mode, etc.

#### **Head temperature sensor**

The head temperature sensor outputs the temperature of the heater board to the printer. The voltage output by the head temperature sensor is read by the A/D board of the MPU as a voltage and converted to digital format to detect the temperature. The print quality is controlled and the head prevented from overheating on the basis of the detected temperature.

#### **Electrode** \*2

The ink-out detection pulse is output to the ink room on the head holder to detect ink-outs in the ink-path.

#### **Index** \*2

The type of BJ cartridge mounted in the printer is output to the printer.

\*1: The connection and order of IDATA differs according to the type of BJ cartridge.

\*2: Some of the electrodes of the color and photo heads are connected to contacts that are shared with the index.

TABLE 4-4 AND GATE CONTACTS AND IDATA ORDER

	BC-60		BC-61/BC-62e Photo	
	Ink optimizer head	Black head	Photo head	Color head
<b>INV</b>	VDDH (High)	GND (Low)	VDDH (High)	GND (Low)
<b>Output sequence of BLOCK1 to 6</b>	BLOCK6→1	BLOCK1→6	BLOCK6→1	BLOCK1→6
<b>BLOCK1</b>	1-7 100-119	212-231	81-84	161-180
<b>BLOCK2</b>	8-25 120-137	232-249	1-6 85-102	181-198
<b>BLOCK3</b>	26-43 138-155	250-267	7-24 103-120	199-216
<b>BLOCK4</b>	44-61 156-173	268-285	25-42 121-138	217-237
<b>BLOCK5</b>	62-79 174-191	286-303	43-60 139-156	235-240
<b>BLOCK6</b>	80-99 192-211	304-310	61-80 157-160	
<b>Order of IDATA*1</b>	Reverse order	Forward order	Reverse order	Forward order
<b>ODDE*2</b>	2, 4, 6-310	1, 3, 5-309	2, 4, 6-240	1, 3, 5-239
<b>EVENE*2</b>	1, 3, 5-309	2, 4, 6-310	1, 3, 5-239	2, 4, 6-240

\*1: Forward order refers to serial data in the same order as the image being printed.

Reverse order refers to serial data in the reverse order to the image being printed.

\*2: The ODDE and EVENE signals from the logic board are input to the black head and ink optimizer head, and to the color head and photo head, in reverse order.

The black head and ink optimizer head, and the color head and photo head, are the same BJ heads arranged symmetrically about a center point. The nozzle arrays are therefore reversed.

For this reason, the order in which BLOCK1 to 6 are output, the arrangement of IDATA, and the connections of ODDE and EVENE are reversed in order to align the ejection of ink at the print media.

In the BC-60 and BC-61/BC-62 Photo, the odd nozzles and even nozzles correspond because of the arrangement of the nozzles in respect to the print media. Therefore, the ODDE and EVENE signal connections are reversed to align the ejection of ink at the print media.

TABLE 4-5 ELECTRODE CONNECTION PINS

Ink-out ink	BC-60		BC-61/BC-62e Photo	
	Ink optimizer head	Black head	Photo head	Color head
<b>Black ink</b>	...	ELBK*1	...	...
<b>Ink optimizer</b>	ELOM*1	...	...	...
<b>Yellow ink</b>	...	...	...	ELYCL*1
<b>Magenta ink</b>	...	...	...	ID1CL/ELMCL*2
<b>Cyan ink</b>	...	...	...	ID2CL/ELCCL*2
<b>Photo yellow ink</b>	...	...	ID2PH/ELYPH*2	...
<b>Photo magenta ink</b>	...	...	ID1PH/ELMPH*2	...
<b>Photo cyan ink</b>	...	...	ELCPH*1	...

\*1: Electrode pin

\*2: Pin shared with index

### 3.2.6 BJ cartridge detection

The sensor signal from the index on the drive circuit is used to detect whether a BJ cartridge is installed and, if so, what type it is.

The index is either open or pulled down via the resistor on the heater board.

**TABLE 4-6 INDEX CONNECTIONS**

	BC-60		BC-61/BC-62e Photo	
	Ink optimizer head	Black head	Photo head*	Color head*
<b>ID1 (signal name)</b>	Open (ID1OM)	Pulled down (ID1BK)	Open (ID1PH/ELMPH)	Open (ID1CL/ELMCL)
<b>ID2 (signal name)</b>	Pulled down (ID2OM)	Pulled down (ID2BK)	Pulled down (ID2PH/ELYPH)	Pulled down (ID2CL/ELCCL)

\*: Pins shared with electrodes.

The detection signals are pulled up to VCC on the logic board and are read by the IO board of the MPU as Low when pulled down and High when open to detect the BJ cartridge.

With combinations of index sensor signals other than above, all print operations are disabled. When print operations are disabled, a BJ cartridge error is displayed.

**TABLE 4-7 INDEX SENSOR SIGNALS AND BJ CARTRIDGE DETECTION**

		1	2	3	4	5	6
Index sensor signals	ID1OM* <sup>1</sup>	N.C.	N.C.	N.C.	N.C.	N.C.	N.C.
	ID2OM	Low	Low	Low	High	High	High
	ID1BK	Low	Low	Low	High	High	High
	ID2BK	Low	Low	Low	High	High	High
	ID1PH	High	High	High	High	High	High
	ID2PH	High	Low	High	High	Low	High
	ID1CL	High	High	High	High	High	High
	ID2CL	Low	Low	High	Low	Low	High
BJ cartridge detection	BC-60	Yes	Yes	Yes	Yes	Yes	Yes
	BC-61	Yes	None	None	Yes	Yes	Yes
	BC-62 Photo	None	Yes	None	None	None	None
Print operation	Monochrome printing	Enabled	Enabled	Disabled	Disabled	Disabled	Disabled
	Color printing	Enabled	Enabled* <sup>2</sup>	Disabled	Disabled	Disabled	Disabled
	Photo printing	Disabled	Enabled	Disabled	Disabled	Disabled	Disabled

\*1: ID1 of the ink optimizer head is not detected by the printer.

\*2: The operator uses the printer driver to select whether printing is continued using only the color ink system, or whether printing is interrupted.

### 3.3 Purge Unit

#### 3.3.1 Function of purge unit

The purge unit of the BJC-7100 printer has four caps: two for cleaning and capping, and two for capping only.

The cap for the ink optimizer head is designed for use with the ink optimizer only so that the ink optimizer does not get mixed with and react with the ink to block the nozzles. Maintenance jets and wipers for the ink optimizer head only are also provided.

##### 1) Capping function

The capping function presses the caps of the purge unit against the face of the print head to prevent the nozzles drying and the inks leaking.

When the cap is open and the printer is idle (waiting for data), the maintenance jets are operated at 15 second intervals if paper is being fed. If no data is received for 120 seconds, the nozzles are capped. If no paper is being fed, the maintenance jets are operated and the nozzles capped after a set time from the last data received. The actual time depends on the ambient conditions and the number of times ink is ejected, etc.

The nozzles are also capped when the *POWER* button is used to turn of the power.

##### 2) Cleaning function

The cleaning function cleans the nozzles under the conditions shown below to maintain the print quality.

In cleaning, paper fragments adhering to the face plate of the print head, ink residue, and ink optimizer and ink aggregates, are wiped away and the nozzles are replenished with fresh ink by purging the old ink. In addition, maintenance jets remove any ink with higher viscosity, air bubbles, mixed inks, and other foreign objects from inside the nozzles and prevent printing irregularities from unused nozzles.

**TABLE 4-8 CLEANING CONDITIONS AND INK CONSUMPTION (AVERAGE)**

Conditions for cleaning	Print Head	Purged ink amount (for reference)		
		BC-60	BC-61	BC-62e Photo
		Black Ink optimizer	Three colors *1	Three normal colors *1 Three photo colors *1
<ul style="list-style-type: none"> <li>• RESET button pressed *2</li> <li>• Printer controlled online using printer driver *2</li> <li>• After BJ cartridge replaced</li> <li>• After ink tank replaced</li> <li>• After ink-out detection</li> </ul>	All heads	0.23g approx.	0.23g approx.	0.23g approx.
	Can be specified	↓	↓	↓
	Applicable heads	↓	↓	↓
	Applicable heads	↓	↓	↓
	Applicable heads	↓	↓	↓
<ul style="list-style-type: none"> <li>• RESET button pressed *3</li> <li>• Printer controlled online using printer driver *2</li> </ul>	All heads	0.46g approx.	0.46g approx.	0.46g approx.
	All heads	↓	↓	↓
<ul style="list-style-type: none"> <li>• First time printer turned on after connecting AC power *4</li> <li>• When printer turned on after 72 hours or more elapsed from last cleaning (3-day timer)</li> <li>• At prescribed printed dot count</li> </ul>	All heads	0.15g approx.	0.31g approx.	0.31g approx.
	All heads	↓	↓	↓
		↓	↓	↓
	Applicable heads			
<ul style="list-style-type: none"> <li>• When printer turned off after printing *5</li> </ul>	All heads	(Not purged)	0.23g approx.	0.23g approx.

\*1: Total amount for yellow, magenta, and cyan color and photo inks.

\*2: Standard manual cleaning.

\*3: Deep cleaning.

\*4: Excluding when BJ cartridge installed and capped in the printer.

\*5: Executed only when printing is performed after turning on the printer.

### 3.3.2 Structure of purge unit

#### 1) Purge drive gear

The purge drive gear is driven via the transmission arm gear by the feed roller, which is, in turn, driven by the paper feed motor. The purge drive gear operates the cam that controls the pump operation and wiping. The cam position is sensed by the purge sensor.

The purge drive gear switches between purging and wiping depending on its direction of rotation.

**2) Wiper**

After the purge operation, the rotation of the purge drive gear is switched so that, when the cap lowers, wiping is performed. The wiper of the BJC-7100 printer's purge unit operates in the direction of the rows of nozzles to wipe any ink from the head face plate.

The ink removed by the wiper from the head face plate is absorbed by the cleaner unit on the back face of the platen chassis and the cleaner on the cap unit.

In addition to vertical wiping by the purge unit, there is an additional wiper on the left of the printer for the ink optimizer head. This special wiper operates horizontally in relation to the rows of nozzles.

The wiper for the ink optimizer head is operated by the carriage travelling back and forth. The effect of removing ink optimizer and ink aggregates is improved by combining the operations of the purge unit wiper and the wiper for the ink optimizer head.

**3) Caps**

The purge unit of the BJC-7100 printer has four caps: two for ink purging and capping, and two for capping only.

After the carriage moves to the capping position, the caps are pressed against the print head faces.

The two caps for ink absorption and capping are attached to the pump and purge ink from the BJ cartridge in the cleaning operation.

The purged ink is sent to the ink absorber on the bottom cover unit.

After the ink has been purged, the carriage moves to the left of the capping position to absorb any waste ink stuck in the cap. So that this waste ink does not mix in the waste ink absorber with the ink optimizer and form aggregates, the absorber is equipped with a wall to separate the ink and ink optimizer.

**4) Pump**

The pump is a tube pump in which a rotating roller is pressed against the ink tube to create a negative pressure so that the ink is purged. The ink and ink optimizer ink tubes are, respectively, attached to the caps.

**5) Slide lock lever**

The slide lock lever is linked to the transmission arm and switches the power from the paper feed motor.

After the carriage moves further to the right of the capping position, the hook on the back of the carriage slides the slide lock lever to the right to release the transmission arm lock. Depending on the direction of rotation of the paper feed motor when the transmission arm lock is released, the driving force of the transmission arm gear drives either the purge unit or the sheet feeder.

**6) Carriage lock lever**

The carriage lock lever is unified with the cap unit and locks the carriage in the capping position to prevent it from moving horizontally when the caps are pressed against the faces of the print heads.

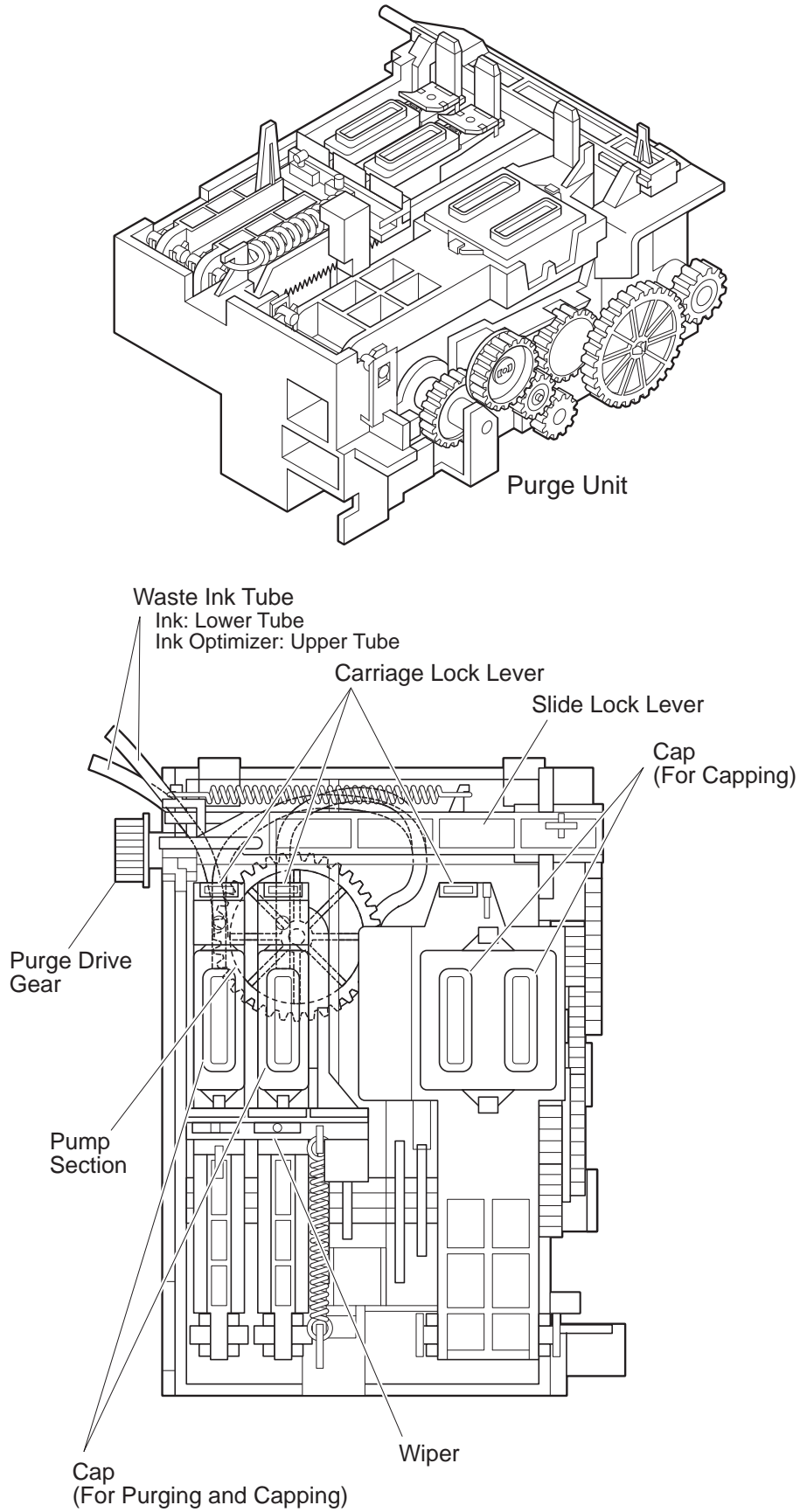

**Figure 4-23 Purge Unit**



### 3.4 Carriage

#### 3.4.1 Carriage functions

##### 1) Attachment of print heads

The carriage mechanically attaches the BJ cartridges, which are connected to the logic board by ribbon cables.

##### 2) Carriage drive

The carriage moves horizontally across the print media driven by the carriage motor via a carriage belt.

##### 3) Paper feed motor drive switching

When the carriage moves further to the right of the capping position, it moves the slide lock lever of the purge unit right to release the transmission arm lock and switch the drive from the paper feed motor to the sheet feeder and purge unit.

##### 4) BJ cartridge maintenance

In the BJC-7100 printer, the ink optimizer head wiper is operated according to the position of the carriage.

When the carriage moves left, the side of the ink optimizer head presses against the wiper lever on the left of the printer to set the wiper. When the carriage then moves right, the hook on the bottom of the carriage pulls the latch lever so that the ink optimizer head wiper wipes the face of the ink optimizer head.

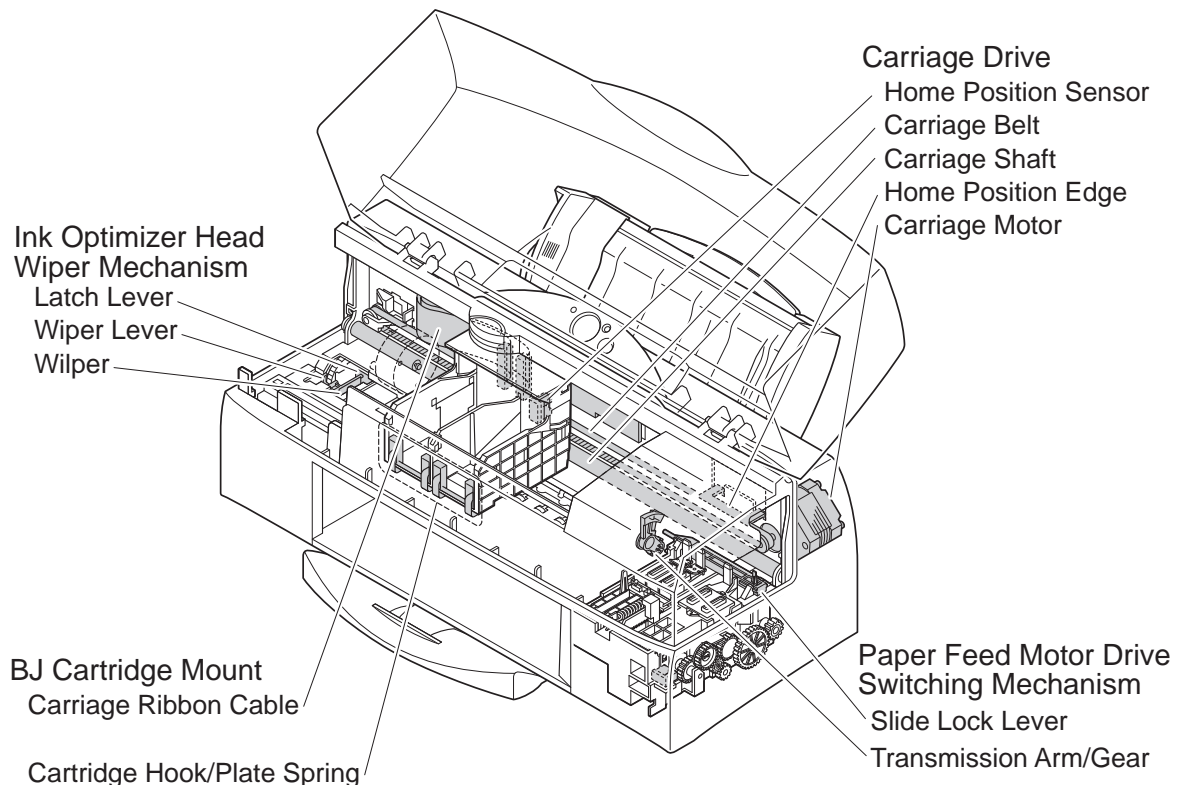

Figure 4-24 Carriage

### 3.4.2 Carriage structure

#### 1) Print head mount

The cartridge hook secures the BJ cartridge to the carriage with a plate spring. When the BJ cartridge is locked on the carriage, the signal contacts of the ribbon cable are pressed against those of the bubblejet head so that the print signals are transferred from the logic board to the BJ cartridge.

#### 2) Carriage drive mechanism

The stepping-type carriage motor moves the carriage horizontally across the print media, the drive being transmitted by the carriage belt. The home position sensor (photo-interrupter) on the carriage board detects the home position edge of the chassis as the initial position, then the stepping pulse is applied to the carriage motor to control the carriage. The carriage motor is current-controlled by the motor drive control from the carriage motor driver. The excitation signals that drive the carriage motor are controlled to the optimum drive pulse width by the printer controller. Mechanical print aberrations during bidirectional printing are automatically corrected by software adjustment of the timing based on home position edge detection.

#### 3) Paper feed motor drive switching mechanism

The paper feed motor drive switching mechanism switches the paper feed motor drive to the purge unit, paper feed, or sheet feeder according to the position of the carriage.

Except when the carriage is at the right edge of the printer, the slide lock lever of the purge unit locks the operation of the transmission arm.

When the carriage is moved further to the right of the capping position (the right edge of the printer), the slide lock lever is released. While the lock is released, the direction of paper feed motor rotation is switched to select either purge operation or sheet feeder operation. If the feed roller is rotated in the direction of feed while the slide lock lever is released, the transmission arm gear moves to the sheet feeder drive gear to drive the sheet feeder.

If the feed roller rotates against the direction of feed while the slide lock lever is released, the transmission arm gear moves to the purge drive gear to drive the purge unit.

#### 4) Ink optimizer head wiper drive mechanism

The ink optimizer head wiper wipes the rows of ink-optimizer nozzles horizontally when a page is printed using the ink optimizer (when printing on plain paper in other than draft mode). The movement of the carriage operates the latch lever and wiper lever.

By combining the ink optimizer head wiper with the purge unit wiper, it is possible to improve the removal of the hard-to-eliminate ink optimizer and ink aggregates in one wiping operation.

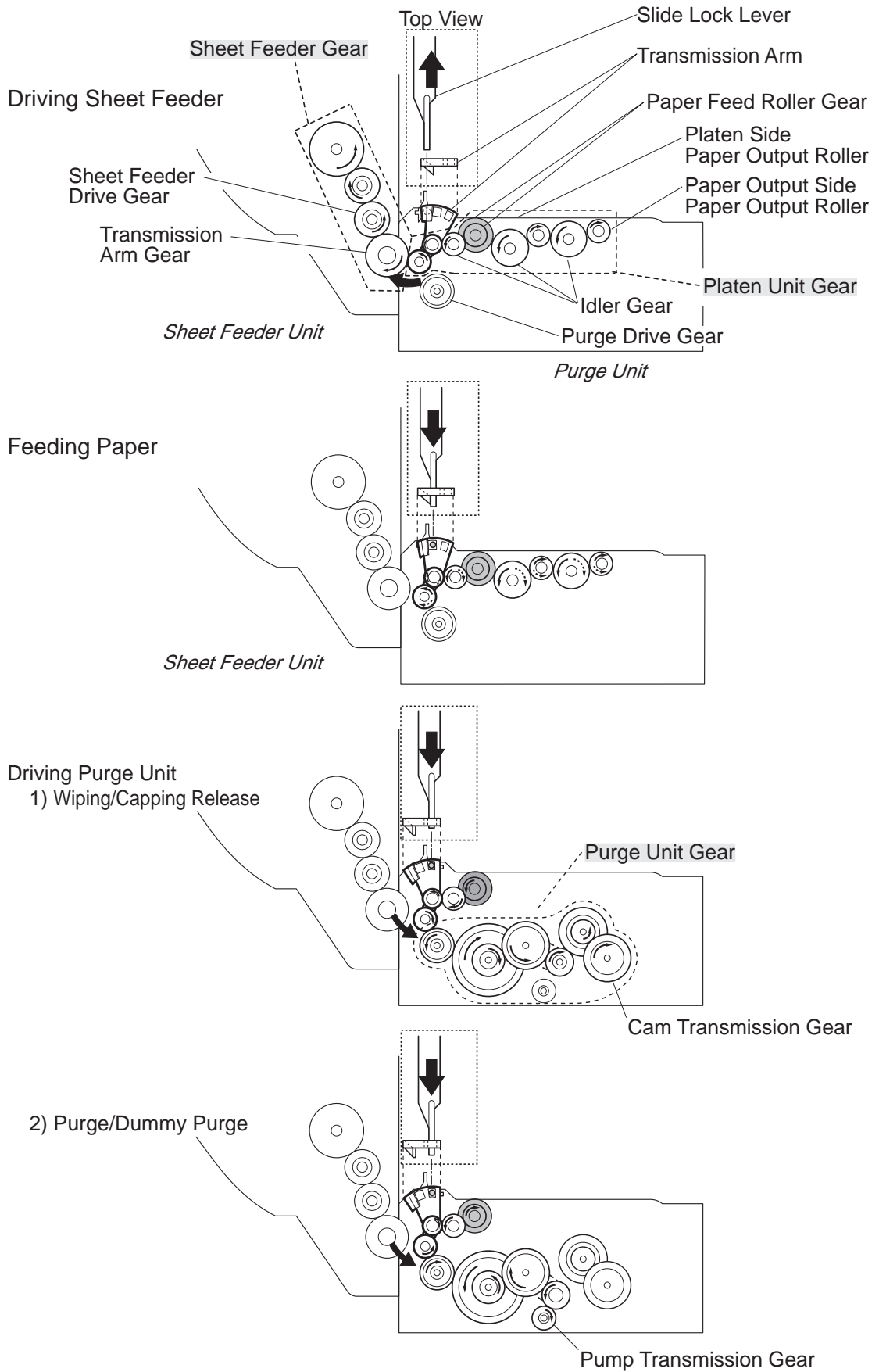

Figure 4-25 Paper Feed Motor Drive Switching

### 3.5 Paper Feed/Sheet Feeder Mechanism

#### 3.5.1 Paper feed/sheet feeder mechanism functions

##### 1) Paper feed function

The paper feed mechanism has two paths: the path taken by sheets fed automatically from the sheet feeder mechanism and sheets fed manually through the manual feed slot. The built-in sheet feeder is driven by the paper feed motor, and loads and automatically feeds the print media. Even envelopes are automatically fed without the need to operate mechanical paper select levers, etc. When pages are fed manually, the manually fed page takes precedence over any media loaded in the sheet feeder.

When the print paper is detected by the paper end sensor (photointerrupter), it is automatically fed to the top-of-page position on the platen by the paper feed roller. During printing, the page feed is controlled by controlling the rotation of the paper feed roller.

On completion of printing, the page is ejected by the paper output roller.

##### 2) Auto platen-head gap adjustment function

The BJC-7100 printer can print without switching the carriage position according to the thickness of the media being printed on.

The paper feed roller is pressed up by coil springs toward the pressure roller while the paper output roller is also pressed up by coil springs toward the spurs. The gap between the head face and the printed media is therefore kept constant regardless of the thickness of the print media.

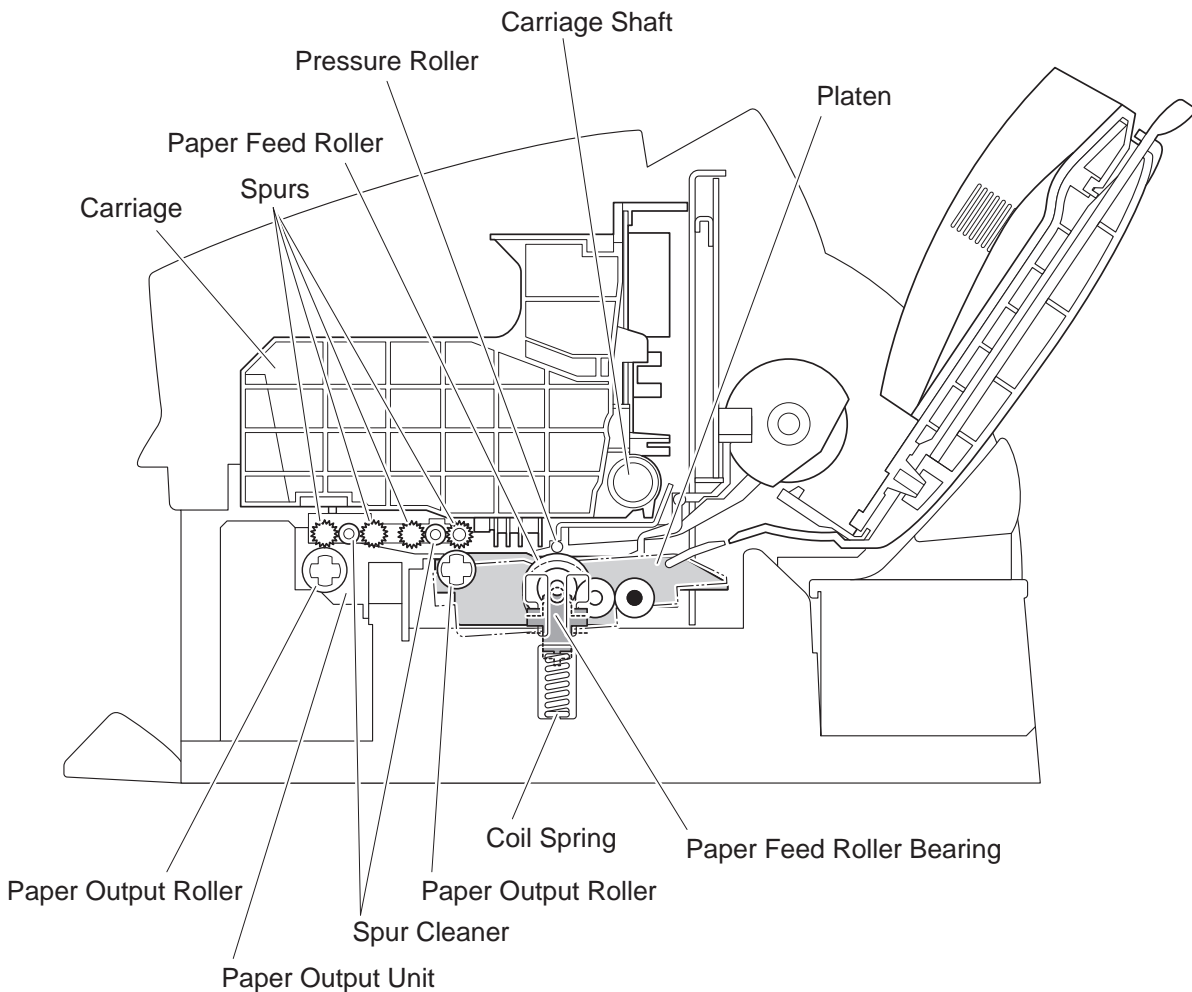

**Figure 4-26 Auto Platen-Head Gap Adjustment**

Auto Sheet Feeder (ASF)

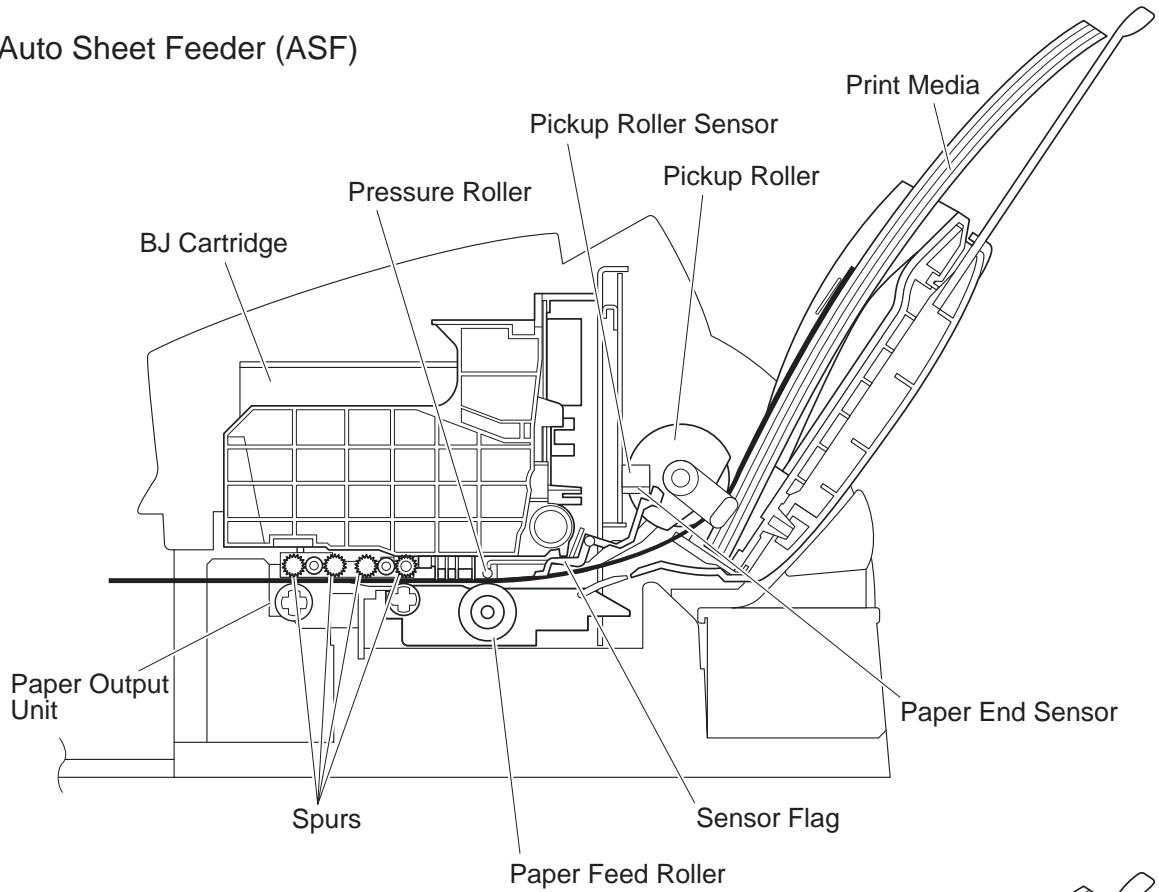

Manual Feed

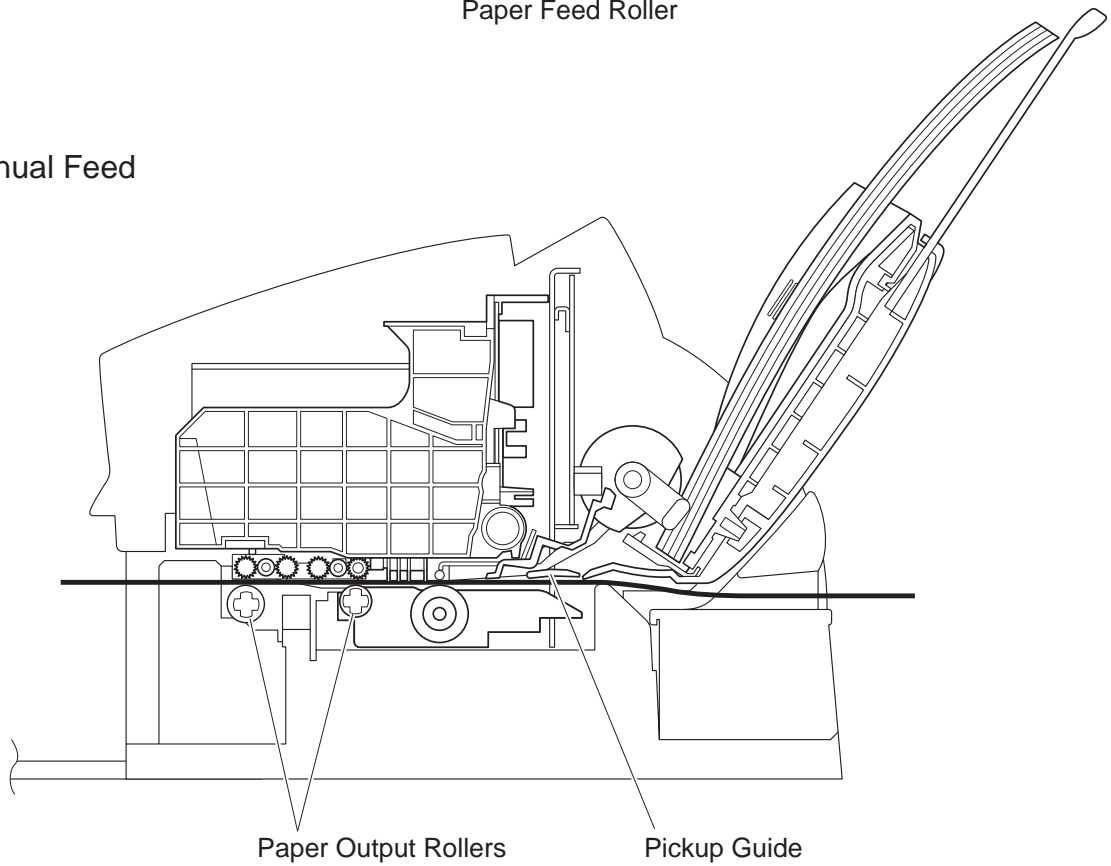

Figure 4-27 Paper Feed Mechanism

### 3.5.2 Paper feed/sheet feeder mechanism structure

The sheet feeder of the BJC-7100 printer has no mechanical paper selection lever.

Provided the print media is within the specifications, the media is fed without having to adjust the carriage position, etc., for the paper thickness.

The print media is loaded into the sheet feeder with the two points of the leading edge and the left corner picked up by the pickup corners and pickup hooks. When the drive from the paper feed motor is transferred to the sheet feeder gear, the pickup roller turns and the printer starts printing.

Print media such as plain paper are fed while pressed against the pickup corners and pickup hooks and fed into the paper feed mechanism. When feeding stiffer materials such as envelopes, the rigidity of the paper is sufficient that the pickup hooks and pickup corners are pressed down and the material can be fed.

The initial position of the pickup roller is determined by the pickup roller sensor (photointerrupter) on the logic board sensing the flag.

When the print media is detected by the paper end sensor, it is automatically fed to the top-of-page position. If no print media is detected even after a feed operation, a paper-out or paper-jam error message is displayed. When manually feeding paper, the user manually inserts the print media via the manual feed slot until it reaches the paper end sensor.

Because manually fed print media are fed through a different path than media automatically fed from the sheet feeder, print media can be manually fed even when media are loaded in the sheet feeder.

Print media that has been fed to the paper feed mechanism are fed to the top-of-page position when the paper end sensor has sensed their existence for two or more seconds.

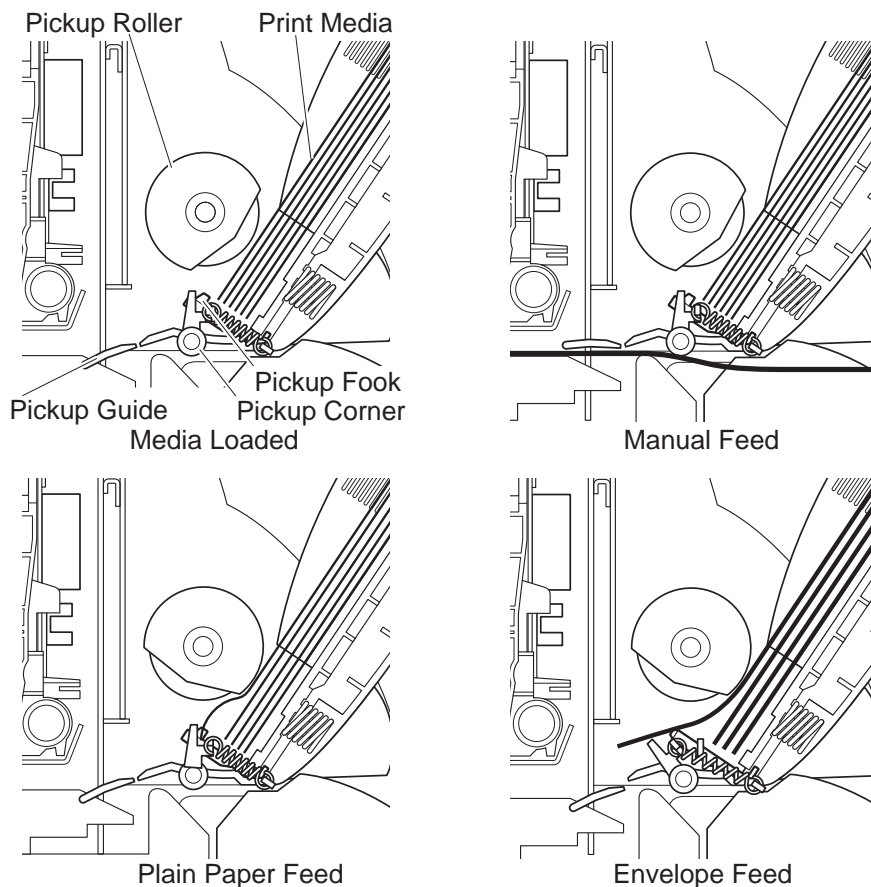

**Figure 4-28 Paper Separator**

## 4. PRINTER ELECTRICAL SYSTEM

### 4.1 Overview of Printer Electrical System

The printer's electrical system can functionally be split into the logic (logic board and carriage board) and the power supply.

The logic converts the data received from the interface into print signals and printer command signals, and drives the BJ cartridge and motors while monitoring the various sensors.

The power supply distributes the DC input power from the AC adaptor into power supplies to drive the logic board, motors, and print heads, etc.

When the AC adaptor is connected to a power outlet and a DC supply is therefore input to the BJC-7100 printer (and the printer has not yet been turned on using the *POWER* button), all buttons except the *POWER* button are inactive, the photointerrupter sensors are inactive, and any signals input from the interface are ignored. In all other respects, the hardware is active.

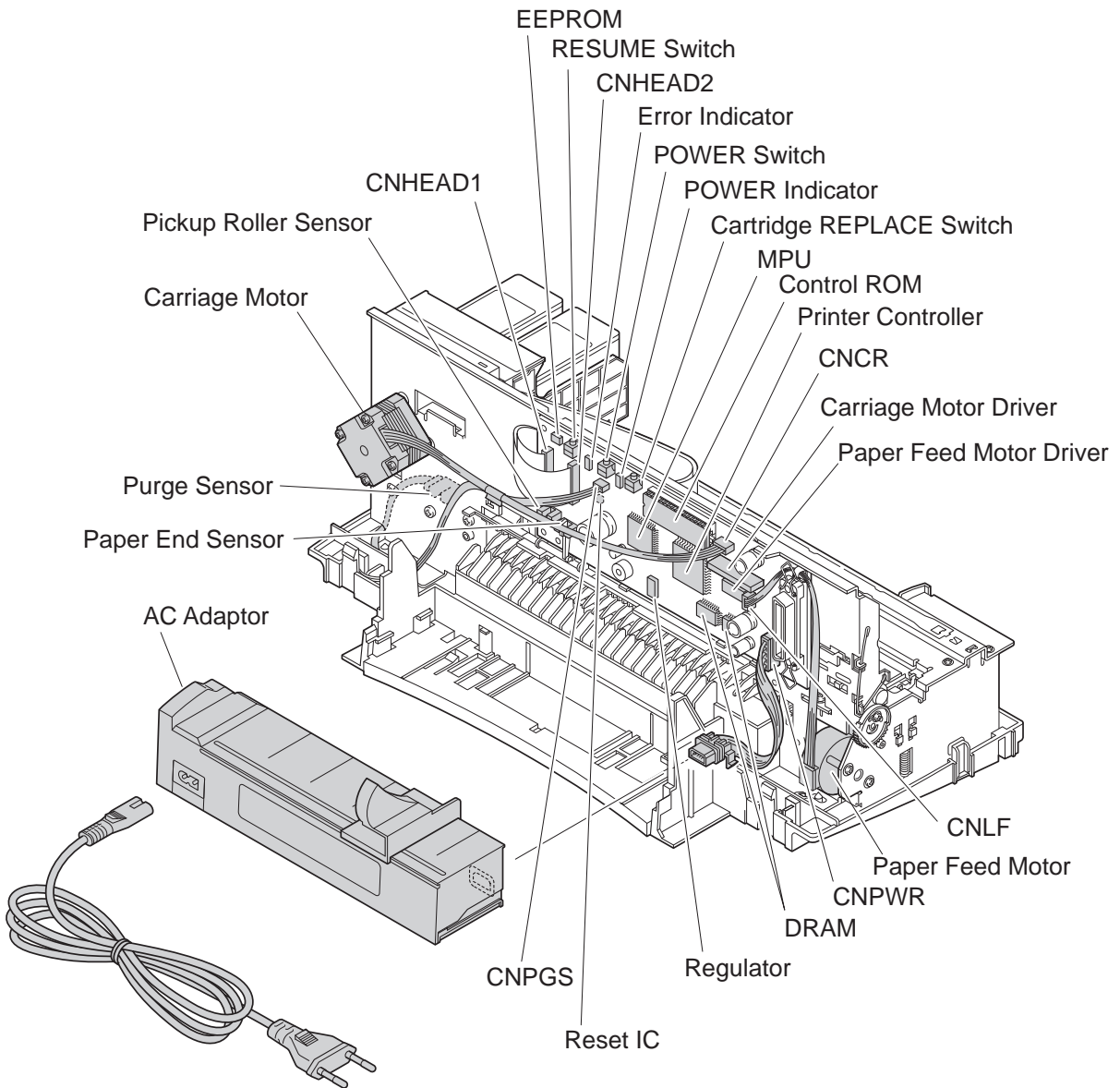

Figure 4-29 Printer Electrical System



## 4.2 Logic

### 4.2.1 Logic block diagram

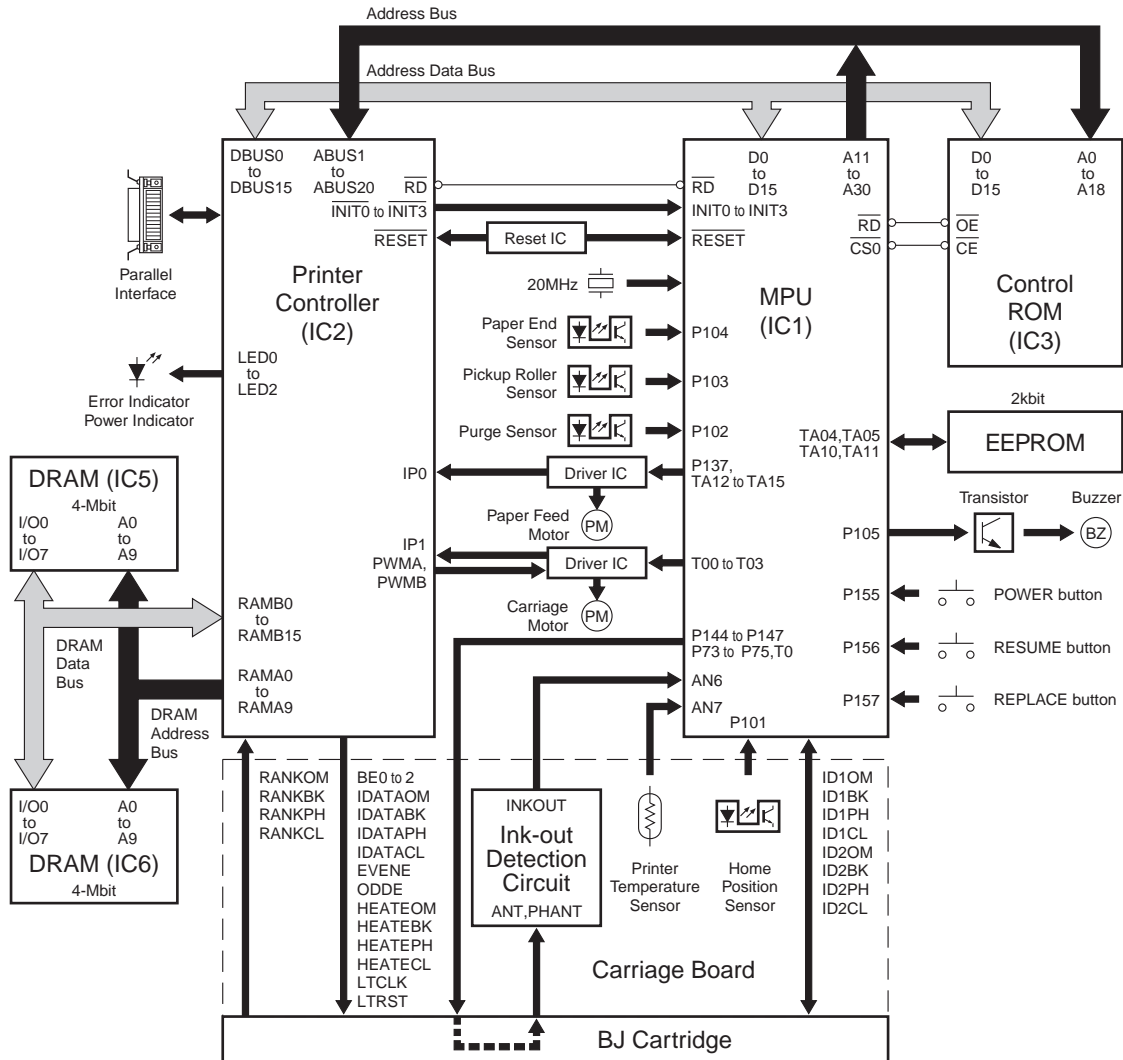

Figure 4-30 Logic Board Block Diagram



## 4.2.2 Logic components

### 1) MPU (IC1)

The MPU accommodates a 32-bit CPU, 25-bit address bus, 2KB work RAM, and nine peripheral IO ports (interrupt controller, DMAC, timers, IO ports, AD converter, DRAM controller, chip select controller, monitor timer, clock & power manager).

#### **Internal CPU**

The 32-bit CPU has 16 32-bit general-purpose registers and operates in sync with a 20MHz external clock input.

#### **Address bus**

The 25-bit address bus port is connected to the printer controller.

#### **Data bus**

The 16-bit data bus port for external devices is connected to the 8Mbit control ROM and printer controller.

#### **Internal RAM**

The MPU has 2KB of internal RAM with 32-bit access.

#### **Interrupt controller**

The MPU has 21 interrupt request factors and 5 external interrupt factors, each triggering interrupt processing.

#### **Direct memory access (DMA) controller**

The MPU has a 4-channel DMA controller that supports a 64MB address space.

#### **Timer (stepping motor controller/sense signal controller)/monitor timer**

The timer has two realtime port timer channels and seven multifunction timer channels, which are connected to the respective sensors and motor drivers.

The stepping motor controller outputs double 1-2 phase excitation drive signals for the carriage motor and 2-phase excitation drive signals for the paper feed motor.

The monitor timer monitors the signals at the realtime port timer terminals.

#### **IO ports**

The IO ports input receive data, output send data, input and output send requests, input and output transmission clock requests, and input and output the transmission clock.

#### **AD converter**

The following analog signals are detected via the internal AD converter.

AN0: Ink optimizer head temperature detection from the head temperature sensor in the BJ cartridge.

AN1: Black head temperature detection from the head temperature sensor in the BJ cartridge.

AN2: Photo head temperature detection from the head temperature sensor in the BJ cartridge.

AN3: Color head temperature detection from the head temperature sensor in the BJ cartridge.

AN4: VH voltage detection from the AC adaptor via the printer controller.

AN5: Head rank detection from the rank resistor in the BJ cartridge via the printer controller.

AN6: Ink-out detection from the antenna on the carriage.

AN7: Printer temperature detection from the thermistor on the control board.

**DRAM controller**

The DRAM controller controls the 10-bit addressing, reading/writing, RAS/CAS, and refresh of the 8Mbit DRAMs (4Mbit ×2).

**Chip select controller**

The chip select controller shows that a valid address has been output for the set area. The chip select controller is connected to the CARTRIDGE button, RESUME button, POWER button, and printer controller.

**Clock & power manager**

The clock and power manager controls the transition to low power-consumption mode. The  $\overline{\text{WAKE UP}}$  pin is connected to the reset IC, and inputs the request to wake up from low power-consumption mode.

**2) Printer controller (IC2)**

The printer controller includes the CPU interface, DRAM interface, Centronics interface controller, print head controller, data processing controller, and IO ports, etc.

**CPU interface**

The CPU interface controls the writing to and reading from the CPU in sync with a 20MHz external clock input.

**DRAM interface**

The DRAM interface controls the 10-bit address and 16-bit data bus, the reading and writing, RAS/CAS, and refresh of the 8Mbit DRAM through the DRAM bus, which is independent of the MPU bus.

**Centronics interface controller**

The Centronics interface controller uses handshaking using the BUSY and  $\overline{\text{ACKNLG}}$  signals to receive the 8-bit parallel data sent in sync with the data strobe ( $\overline{\text{STROBE}}$ ) signal from the host PC. It also controls the other interface signals. The data received from the interfaces is stored in the DRAM receive buffer. The MPU analysis this data and, if deemed to be print data, it is processed by the DMA. When the printer initialize ( $\overline{\text{INIT}}$ ) signal is input from the interface, the Centronics interface controller outputs a BUSY signal. When  $\overline{\text{INT0}}$  is output to the MPU, the printer is initialized after any print data in the print buffer has been printed.

**Print head controller**

To drive the print head, the print head controller outputs the block signal and heat enable signal at the same time as the print data read from the DRAM print buffer is sent as serial data to the print head.

The transfer of print data (IDATA OM, IDATA BK, IDATA PH, IDATA CL) to the print head is synchronized to the 5MHz clock HDCLK signal. The block signals (BE0, BE1, BE2, ODDE, and EVENE), the pulse signals (HEAT OM, HEAT BK, HEAT PH, and HEAT CL), and the head temperature signals (SHON OM, SHON BK, SHON, PH, and SHON CL) are output to drive the print head.

**Data processing controller**

The data processing controller processes the data in the print buffer by DMA. The data processing controller performs palette expand processing of the print data for photo printing, 1200dpi smoothing, and conversion of the raster print data into column oriented print data

**IO ports**

The BJ cartridge rank signals, etc., are input to the IO ports. The power indicator and error indicator lighting control signals, etc., are output from the output ports.

**3) Control ROM (IC3)**

The 8Mbit control ROM contains the printer control program.

**4) DRAMs (IC5 and IC6)**

The 8Mbit DRAMs (4Mbit  $\times 2$ ), which are controlled by the printer controller, are used as the receive buffer, download buffer, print buffer, and working area.

**5) Reset IC (IC8)**

The reset IC senses the supply voltage when the power is turned on or when it is interrupted, and resets the MPU and printer controller.

**6) EEPROM (IC7)**

The 2Kbit EEPROM, which is controlled by the printer controller, stores the various printer settings, total waste ink amount, page count, print head removal/installation count, and resume count, etc.

**7) Paper feed motor driver (IC14)**

The paper feed motor driver, which is controlled by the MPU, performs constant current bipolar drive of the paper feed motor, which is controlled using 2-phase excitation. There are two drive circuits in the IC.

**8) Carriage motor driver (IC13)**

The carriage motor driver, which is controlled by the MPU, performs constant current bipolar drive of the carriage motor, which is controlled using double 1-2-phase excitation.

The carriage motor switches the peak current among 5 steps according to the switching signals from the MPU to maintain optimum carriage motor drive. There is one drive circuit in the IC.

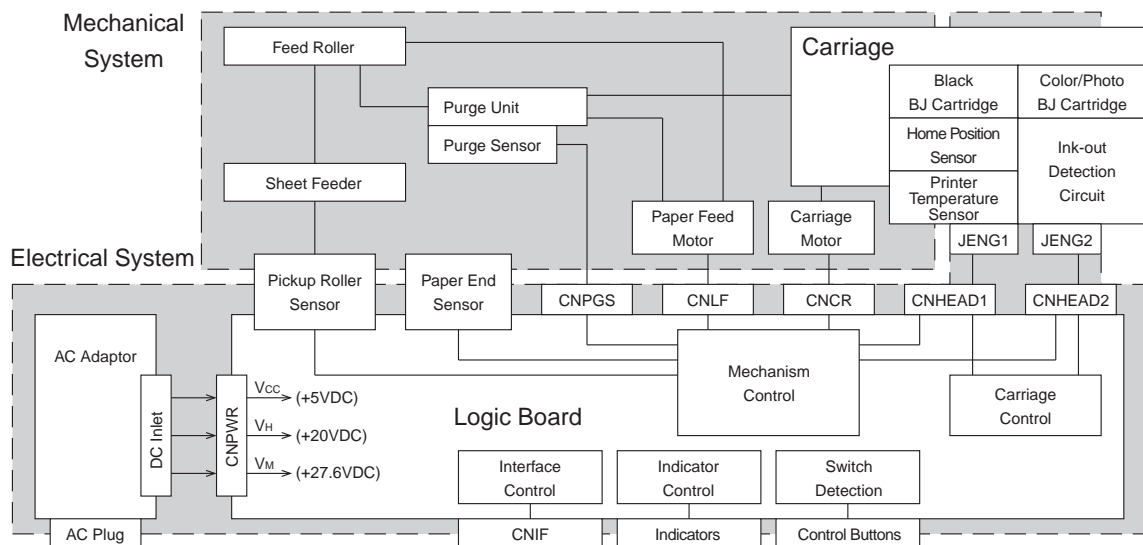

**Figure 4-31 Printer Block Diagram**

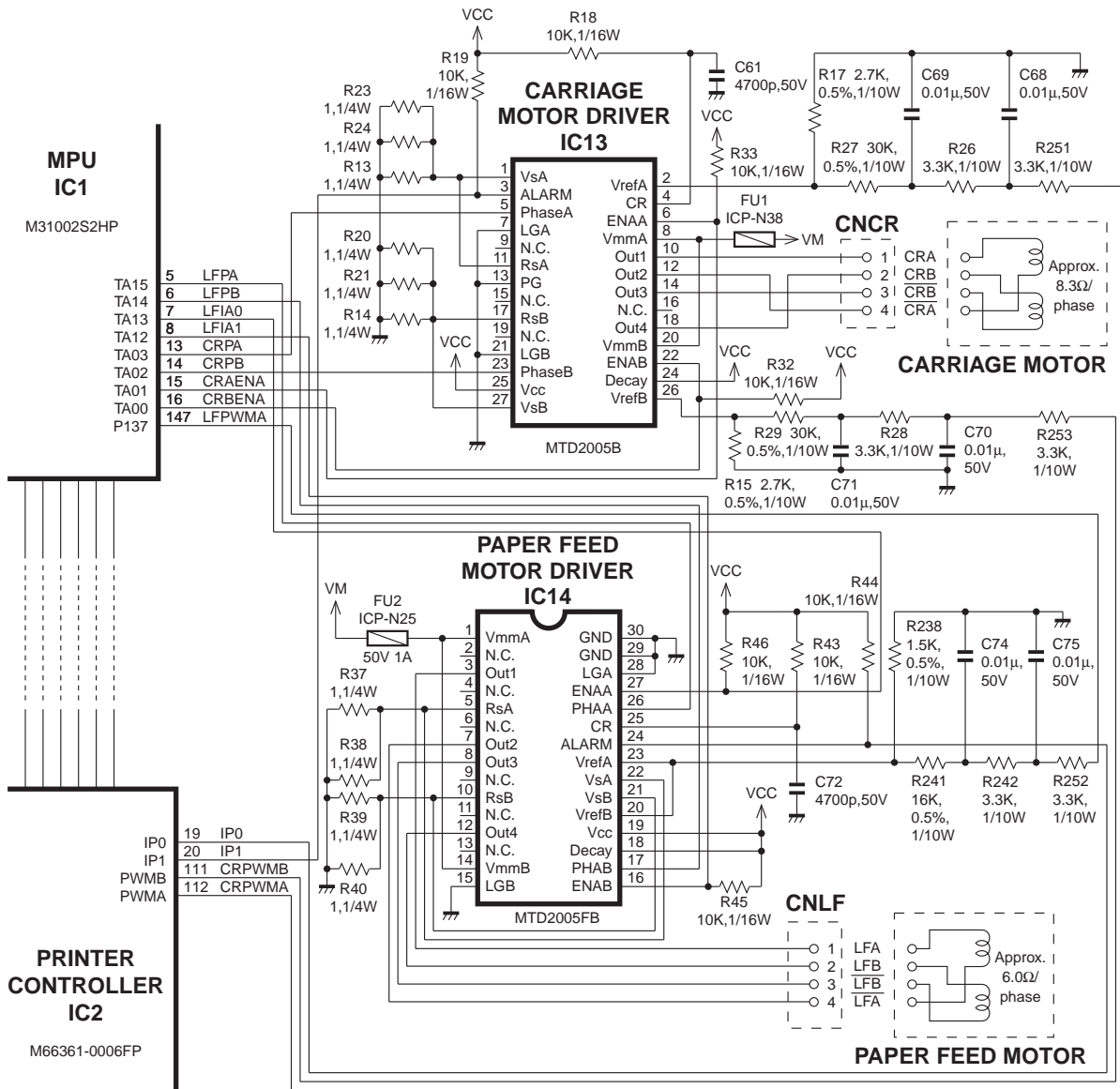

Figure 4-32 Motor Drive Circuit

## 4.3 Electrical System

### 4.3.1 Input power supply (AC adaptor)

The AC adaptor supplies the voltages to the printer power supply circuit.

The AC adaptor outputs three DC voltages: Vcc: 5.0VDC, BJ head drive VH: 20VDC, motor drive VM: 27.6VDC.

The AC adaptor is mounted on the back of the printer so that the DC output pins of the AC adaptor align with the DC power cable of the printer.

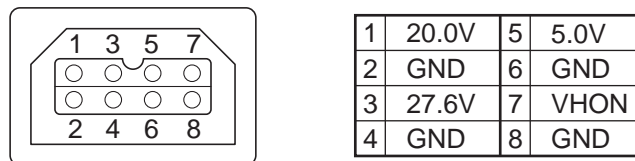

**Figure 4-33 AC Adaptor Output Voltages**

### 4.3.2 Output voltages

#### 1) Vcc (5±0.25V)

The Vcc supplied from the input power supply is used as the pullup voltage for the POWER button, and to drive the beeper. In addition, the Vcc is distributed as +5VDC power to the MPU, printer controller, EEPROM, control ROM, DRAMs, motor driver, and other ICs such as the reset IC, and for operating the ink-out detection circuit. (VDDH, Vcc2, Vcc3, Vcc4, Vcc5, Vcc6)

#### 2) VH (20±0.3VDC)

The VH is supplied to the print head.

The VH output voltage is supplied to the BJ cartridge subheater temperature driver transistor and driver transistors in the nozzles.

#### 3) VM (27.6±1.5VDC)

The VM is output as is and used to drive the carriage motor driver and paper feed motor driver.

# 5. DETECTION FUNCTIONS

## 5.1 Sensor-based Detection Functions

The BJC-7000 has the following sensors for detecting the printer status.

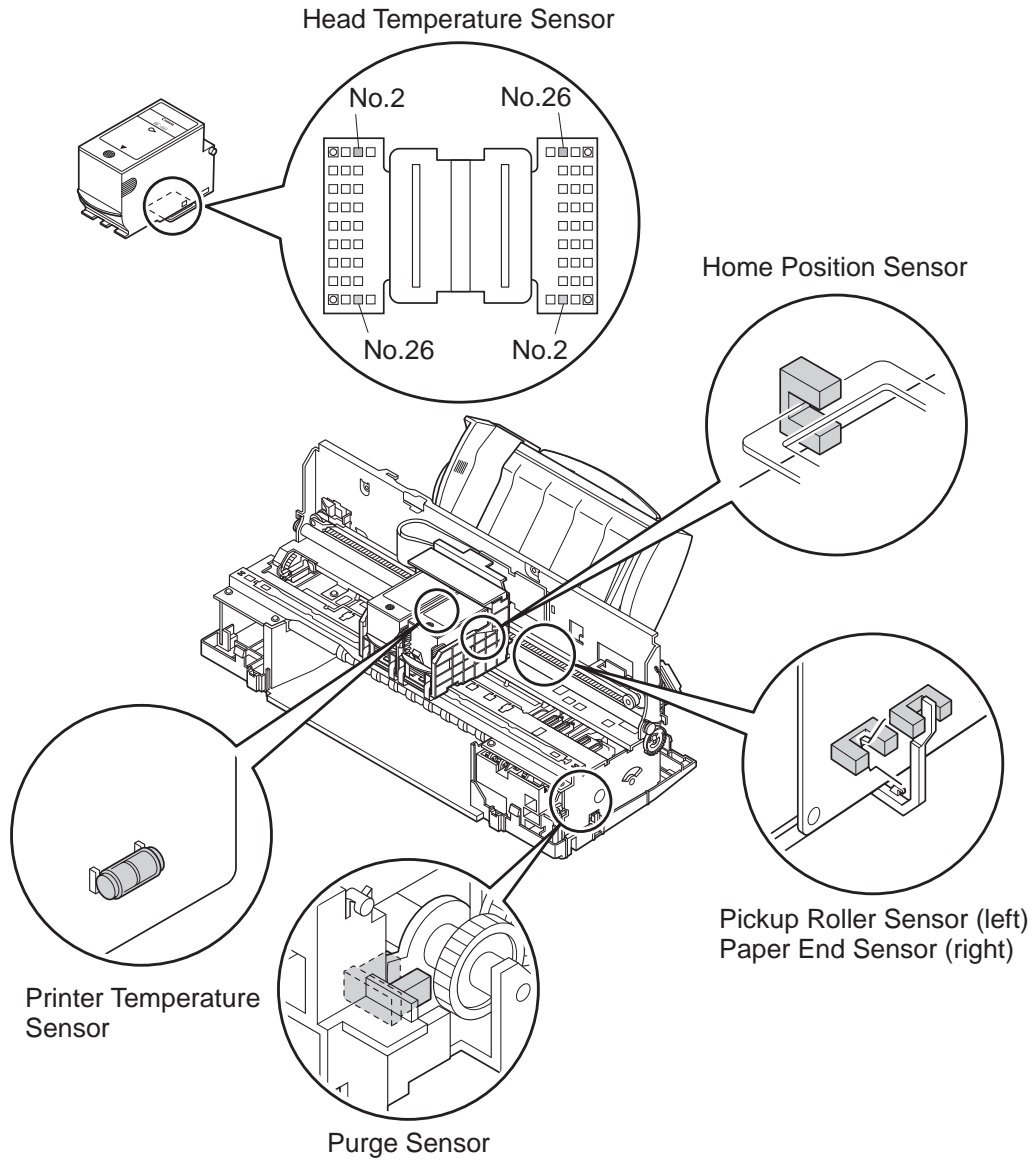

Figure 4-34 Sensor Positions

**Purge sensor**

The purge sensor uses a transmission-type photointerrupter to detect the capping position of the purge unit. When the flag on the cam gear in the purge unit interrupts the purge sensor, the module phase is deemed to be in the capping position.

**Paper end sensor**

The paper end sensor uses a transmission-type photointerrupter to detect the presence of paper in the paper feed system. When the paper presses against the paper end sensor arm, the paper end sensor is interrupted, indicating that paper has been picked up by the paper feed system.

**Pickup roller sensor**

The pickup roller sensor uses a transmission-type photointerrupter to detect the initial position of the pickup roller of the sheet feeder. When the flag in the pickup roller interrupts the pickup roller sensor, the pickup roller is deemed to be in the initial position.

**Home position sensor**

The home position sensor uses a transmission-type photointerrupter to detect the home position of the carriage. When the home position edge of the chassis interrupts the home position sensor on the carriage board, the carriage is deemed to be in the home position.

**Printer temperature sensor**

The thermistor on the carriage board detects the temperature inside the printer. The printer fetches the voltage output by the printer temperature sensor. This voltage, which varies according to the temperature, is converted from analog to digital to determine the printer temperature. The temperatures detected by the printer temperature sensor and the head temperature sensor are used to control the printer to achieve optimum printing, and to prevent overheating.



---

The head temperature sensors are built into the heater boards of the respective print heads. See *Part 4, section 3.2.2, "Structure of BJ head unit"* (page 4-19) for details.

The printer decides if an error has occurred from the readings from the various sensors. For details, see *Part 3, section 3.1.2, "Service calls"* (page 3-15).

The states of the purge sensor, paper end sensor, pickup roller sensor, and home position sensor are detected by the MPU's input ports. The detection signal is inverted according to whether the sensor is interrupted or open.

---

## 5.2 Miscellaneous Detection Functions

In addition to sensor-based detection functions, the BJC-7100 printer also has the following detection functions.

### 5.2.1 Waste-ink amount detection

This function processes the amount of waste ink (and ink optimizer) in the waste ink absorbers.

The printer stores the total waste ink amount absorbed by the waste ink absorbers from cleaning and maintenance jet operations in the EEPROM on the logic board. Post-absorption evaporation is taken into account when calculating the amount. The total waste ink amount is updated when the power is turned off, on completion of cleaning operations, and when a page is output. When the waste ink amount approaches the absorber's capacity, the printer stops printing.



When the waste ink amount (or ink optimizer amount) reaches 95% of the waste ink absorber capacity, the printer generates a waste ink alarm (operator call). You can press the *RESUME* button to continue operating the printer. When the waste ink amount (or ink optimizer amount) subsequently reaches 100% absorber capacity, the printer outputs a waste-ink full error (service call) to prevent ink leaks.

### 5.2.2 BJ cartridge detection

The detection signals from the index unit in the print head heater board are used to detect the presence and type of BJ cartridge.

For details, see *Part 4, section 3.2.6, "BJ cartridge detection" (page 4-28)*.

### 5.2.3 Ink-out detection

#### 1) Detection operation

An ink-out detection pulse is output to the ink paths in the ink room in the head holder. The pulse is transmitted via the ink path to the ink sponges and received by the electrode on the carriage. It is then amplified by the carriage board and read by the AD board of the MPU, and converted from analog to digital to detect the existence of ink.

The electrode is located opposite the ink room in the head holder.

#### 2) Timing processing

Ink-out detection is performed for all inks in a single sweep in the following order: ink optimizer, black ink, color ink, and photo ink.

In the case of the color and photo inks, detection proceeds from yellow through magenta to cyan. Post ink-out detection processing differs according to the timing.

**TABLE 4-9 INK-OUT DETECTION TIMING**

Detection timing	Post ink-out detection processing
• When power turned on using <i>POWER</i> button	Cleaning *
• After page is output	Cleaning *
• After all cleaning operations	Transition to ink-out error (operator call)
• When head overheat is detected	See <i>Part 4, section 2.5, "Head Overheat Protection" (page 4-12)</i> for details.

\*: The cleaning operation differs according to which ink has run out. See *Part 4, section 3.3.1, "Function of purge unit" (page 4-29)* for details.



### 3) Ink-out error display

When an ink-out error occurs, replace either the BJ cartridge or ink tanks by either pressing the *REPLACE* button on the printer or using the printer driver utility.

The cartridge or tank replacement procedure is as follows:

1) If the black ink or ink optimizer has run out, the *ERROR* indicator turns ON and the beeper sounds 3 times. If the color or photo inks have run out, the beeper sounds 4 times.

If you press the *RESUME* button, the beeper sounds again so that you can know which ink has run out.

2) Press the *REPLACE* button to move the carriage to the cartridge replacement position so that you can replace the appropriate BJ cartridge or ink tank.

If there is any print data in the receive buffer, the printer restarts printing.

An ink-out error message is displayed on the utility sheet of the printer driver to indicate the ink that has run out.

Follow the instructions displayed on the host PC's screen to replace the BJ cartridge or ink tank.

When using the bidirectional interface, the head alignment mode is automatically selected after the BJ cartridge has been replaced. Follow the instructions on the PC screen to align the print heads.



---

Ink-out detection is designed to inform the operator that the ink has run out. This function does not automatically halt printing before the ink actually runs out or before print faults develop due to bubbles in the ink paths.

After replacing a BJ cartridge, be sure to align the BJ cartridges.

If you deal with the ink-out error at the printer rather than using the printer driver, or if you use the printer driver utility, but the interface in use is not bidirectional, head alignment mode is not automatically selected. It is therefore necessary to manually select head alignment mode and align the heads. See *Part 3, section 1.3.3, "Installing the BJ cartridge" (page 3-4)* for details of head alignment.

Note that the ink-out detection can be disabled using the printer driver's hidden functions.

See *Part 3, section 3.3.2 "Service mode of printer driver" (page 3-18)* for details of the printer driver's service mode.

---

This page intentionally left blank



# *Part 5*

# MAINTENANCE

Page	
5 - 1	1. MAINTENANCE
5 - 1	1.1 Parts for Periodic Replacement
5 - 1	1.2 Consumable Parts
5 - 1	1.3 Consumables
5 - 1	1.4 Periodic Maintenance
5 - 2	2. SERVICING TOOLS
5 - 2	2.1 List of Tools
5 - 3	3. APPLYING GREASE
5 - 4	4. DISASSEMBLY AND REASSEMBLY
5 - 4	4.1 Disassembly and Reassembly
5 - 4	4.2 Notes on Disassembly and Reassembly
5 - 6	4.3 Waste Ink Absorbers
5 - 7	4.4 Assembling the Chassis
5 - 8	5. ADJUSTMENTS
5 - 8	5.1 Adjustment Locations
5 -13	6. TROUBLESHOOTING
5 -13	6.1 Troubleshooting Overview
5 -14	6.2 Diagnosis
5 -37	7. CONNECTOR LAYOUT AND SIGNAL ASSIGNMENT
5 -37	7.1 Logic Board
5 -39	7.2 Carriage Board
5 -44	8. CIRCUIT DIAGRAMS
5 -44	8.1 Parts Layout
5 -47	8.2 Circuit Diagrams



# 1. MAINTENANCE

## 1.1 Parts for Periodic Replacement

Level	Part
User	None
Service personnel	None

## 1.2 Consumable Parts

Level	Consumable	Replacement Guide
User	None	
Service personnel	Spur/Spur cleaner/spur unit	When spur marks become evident

## 1.3 Consumables

Level	Consumable
User	Black BJ cartridge [BC-60] Color BJ cartridge [BC-61] Photo BJ cartridge [BC-62e Photo] Ink tank for color BJ cartridge [BC-61 Color] Ink tank for photo BJ cartridge [BCI-62 Photo]
Service personnel	None

## 1.4 Periodic Maintenance

Level	Location
User	None
Service personnel	None



The BJC-7100 uses a range of inks and an ink optimizer when printing on plain paper in other than draft mode. The ink optimizer is an almost colorless, transparent fluid. For simplicity in this manual, we refer to the ink optimizer for plain paper simply as "ink optimizer" or just "optimizer". We also refer to the various colored inks and the ink optimizer for plain paper simply as "inks".

## 2. SERVICING TOOLS

### 2.1 List of Tools

Ordinary Tools	Note
Phillips screwdriver	For removing and replacing screws
Blade screwdriver	For removing plastic parts
Tweezers	For removing and installing coil springs
Flat brush	For applying grease (one per grease type)
Multimeter	For troubleshooting

Special Tools (part No.)	Note
Grease (MOLYKOTE PG-641) (CK-0562)	For application to specified locations (see Figure 5-1.)
Tension spring (QY9-0046)	For use when securing idler pulley (See Figure 5-9.)
Gap gage 1.2mm THICKNESS GAUGE KIT (QY9-0030-000)	For use when checking and adjusting plate-head gap For use when checking and adjusting platen-head gap (See Figure 5-15 to 5-20)
THICKNESS ADJUSTER (QY9-0031-000)	For use when checking and adjusting platen-head gap (See Figure 5-15 to 5-20)

### 3. APPLYING GREASE

Apply the MOLYKOTE PG641 greases at the points shown below. Smear a thin film of the appropriate amount of grease smoothly over the whole area to be lubricated.



The BJC-7100 uses three types of grease. Only apply the specified grease to the specified locations. Never apply grease to locations other than those indicated. Also take care that grease does not get onto parts neighboring the indicated locations.

#### MOLYKOTE PG641

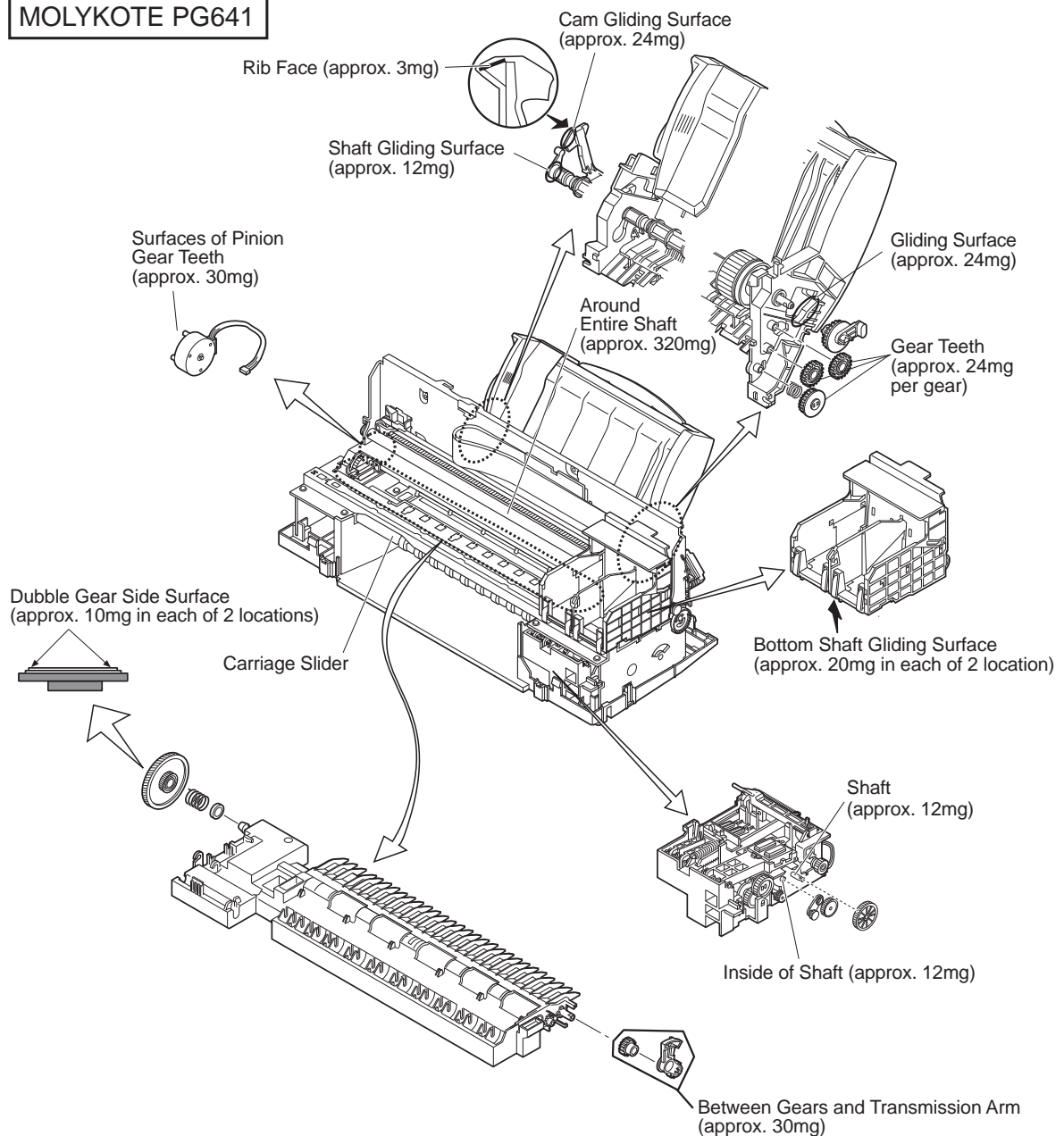

Figure 5-1 Grease Points

## 4. DISASSEMBLY AND REASSEMBLY

### 4.1 Disassembly and Reassembly

When disassembling or reassembling the printer, refer to the parts catalog. The Figure No. of the illustrations in the parts catalog are in the order of the disassembly sequence.

The parts catalog also contains close-up diagrams where additional care is required.

### 4.2 Notes on Disassembly and Reassembly

Note the following when disassembling or reassembling the printer.

#### 4.2.1 Main cover

Before removing or installing the main cover, remove the connector cover. It is extremely difficult to remove or reinstall the main cover, and parts can easily be broken, when the connector cover is attached to it.

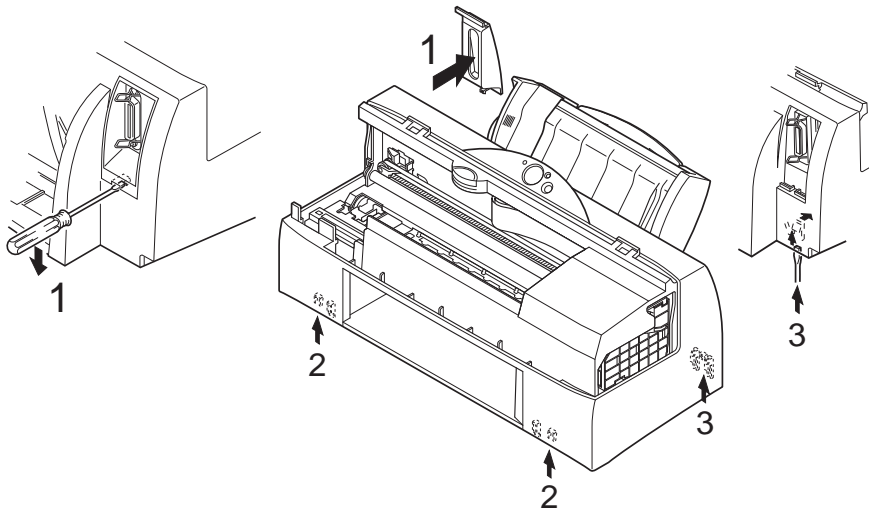
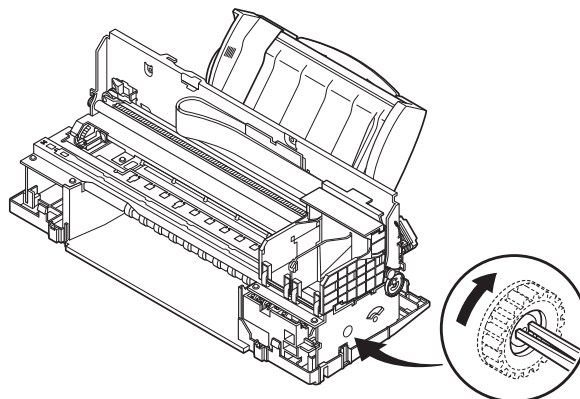

Figure 5-2 Main Cover and Connector Cover

#### 4.2.2 Carriage unit

When the cartridges are installed and the power is OFF, the carriage is normally locked in the capping position. The locking mechanism is in the purge unit and prevents the carriage moving from the capping position exposing and potentially damaging the print head while the printer is being shipped or moved.

When servicing the printer, you can manually release this lock using the following procedure.



\* : See CAUTION on page 1-13

Figure 5-3 Releasing the Carriage Lock



### 4.2.3 Bearings at ends of support shaft

The two bearings at the end of the support shaft are secured by fixing screws in placed after being positioned at the factory. Never disassemble these bearings (except for head gap adjustment). Red fixing screws are used to distinguish them from other screws. The bearings need not be removed to remove the carriage.

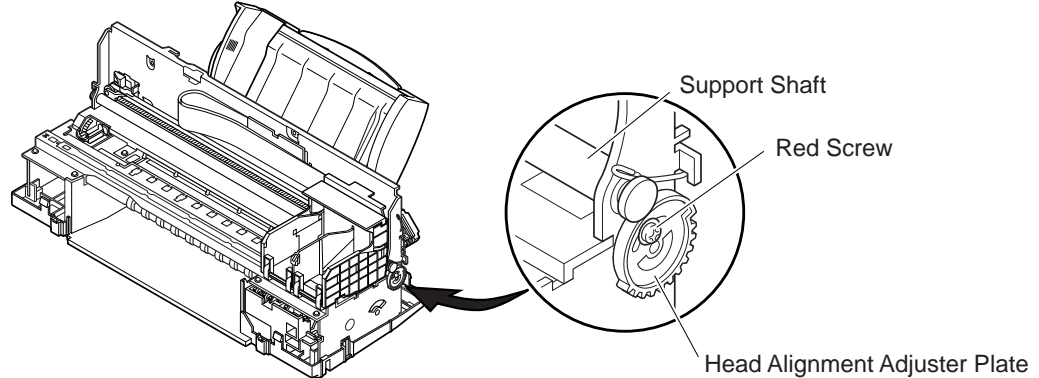

Figure 5-4 Bearings at Ends of Support Shaft

### 4.2.4 Purge unit and bottom case assembly

When the purge unit is assembled with the bottom case, **check that the two tubes from the purge unit lead to the ink absorbers.** Take care when assembling that the ends of the tubes are clear; ink drying in the tubes would hinder purging.

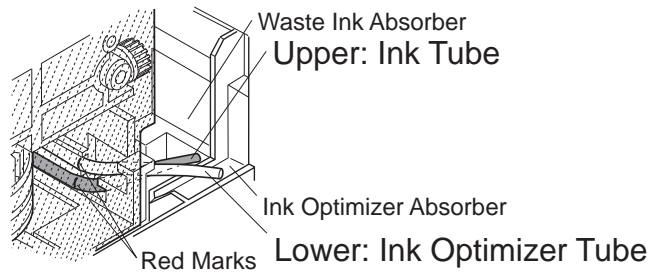

Figure 5-5 Purge Unit and Bottom Case Assembly

### 4.2.5 Securing idler pulley assembly screw

If you have loosened the idler pulley assembly screw, as when removing the carriage, you must use the special tension spring (QY9-0046) when reassembling.

Before tightening the screw, move the carriage horizontally several times to equalize the belt tension. \*

After tightening the screws, remember to remove the tension spring.

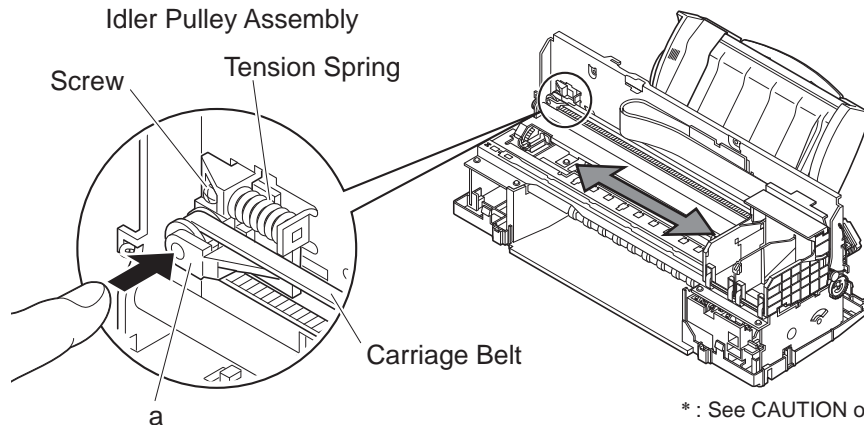

\* : See CAUTION on Page 1-14.

Figure 5-6 Tightening Idler Pulley Assembly Screw

### 4.3 Waste Ink Absorbers

If you are replacing the waste ink absorber (and/or waste ink optimizer absorber) because of a waste ink alarm or waste-ink full error, replace both top and bottom absorbers together. Also replace the absorbers for the maintenance jets. In other cases, replace both top and bottom absorbers if possible even when there is comparatively little waste ink. For various manufacturing reasons, several different materials are used for the waste ink absorbers. If you replace only one of the absorbers, the top and bottom may be of different materials, which could result in problems. (All service parts absorbers are of the same material. Differences in materials are visually apparent.)

Clean the absorber cover if necessary.

Be sure to reset the EEPROM when you replace the waste ink absorbers. If you do not reset the EEPROM, the waste ink alarm or waste ink full error will not be cancelled.

See "Part 3: 3.8.2 Resetting EEPROM data" (page 3-22) for details of how to reset the EEPROM.

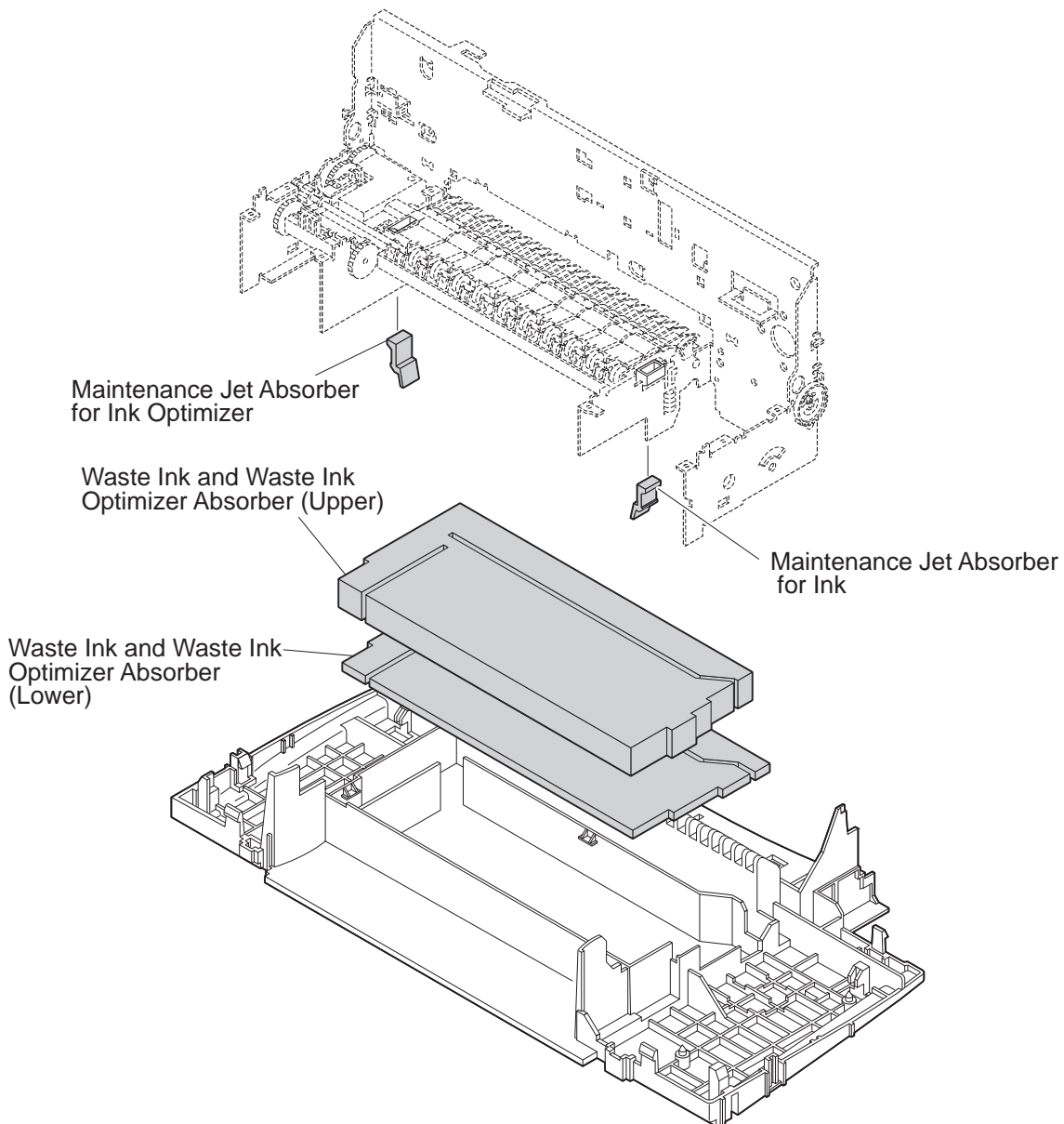

**Figure 5-7 Maintenance Jet and Waste Ink Absorbers**

#### 4.4 Assembling the Chassis

Follow the procedure below to tighten the following screws (total 9 screws securing front chassis unit and rear chassis) after you have replaced parts.

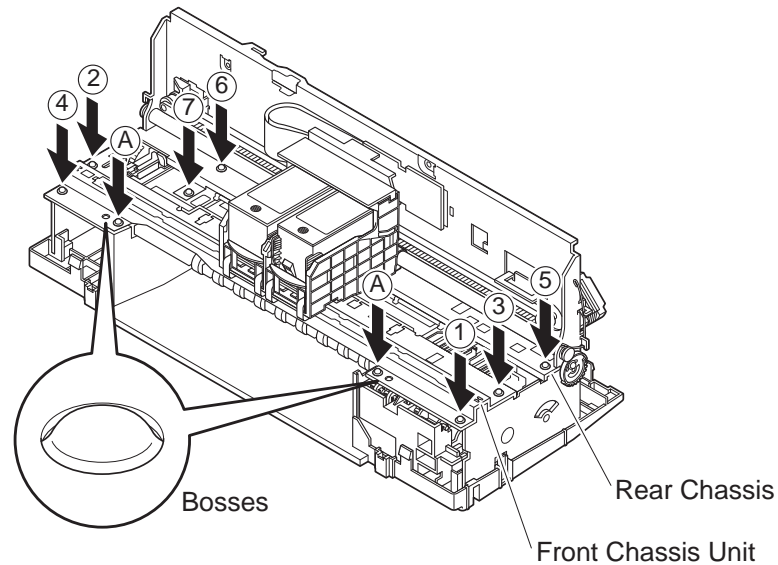

**Figure 5-8 Tightening the Chassis Fixing Screws**

- 1) When both the front chassis unit and rear chassis have been removed from the body, fit the rear chassis onto the body first.
- 2) After you have fitted the front chassis unit and rear chassis onto the body, attach the nine screws. When you start attaching the screws, leave them in a loose state.
- 3) First, tighten two screws (A) on the front of the front chassis unit. Before you tighten these screws, make sure that the bosses to the outside of these screws are properly fitted in place.
- 4) Alternately tighten four screws (1) (2) (3) and (4) on both ends of the front chassis unit.
- 5) Tighten three screws (5) (6) and (7) on the rear chassis in that order.
- 6) Firmly tighten all screws again.

## 5. ADJUSTMENTS

### 5.1 Adjustment Locations

#### 5.1.1 Adjusting registration

Adjust the registration along the horizontal and vertical directions using the printer driver. This adjustment is the same as the operation when the user installs the printer or replaces the BJ cartridge. For details, see "Part 3: 1.3.3 3) Aligning the print heads" (page 3-5).

#### 5.1.2 Checking and adjusting the head gap

Check that the head gap is correct when you have loosened the following screws, for example during replacement of parts, or when the printer has been strongly impacted for example by its being dropped.

This check is also necessary if the paper scrapes against the head during printing or when color drifts frequently.

The head gap must be adjusted if it has deviated out of the allowable range of 1.2 to 1.6 mm.

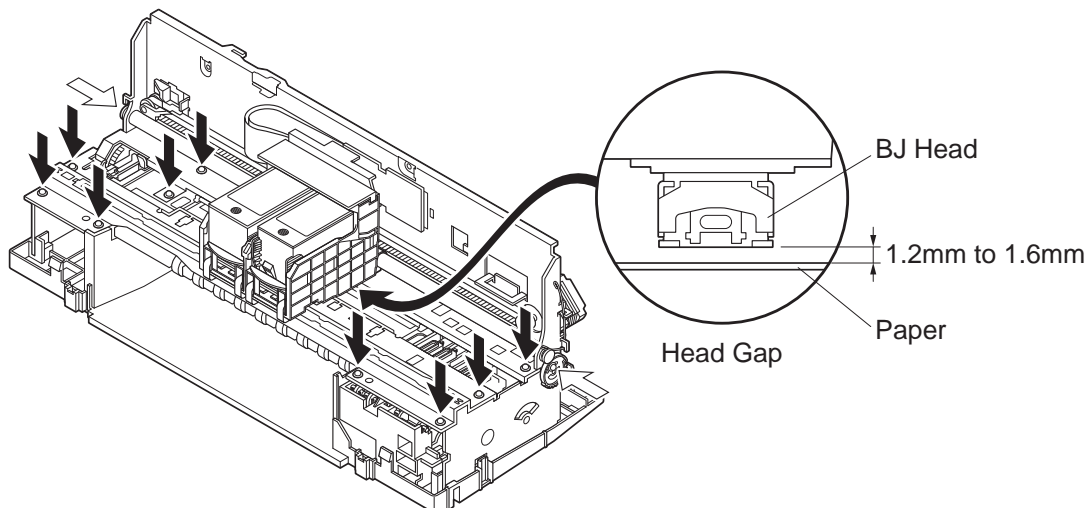

**Figure 5-9 Screws Influencing Head Gap**

The following tools are required for checking and adjusting the head gap.

Thickness gauge 1.2 mm (QY9-0016-000)	Used for checking the head gap
Thickness gauge kit (QY9-0030-000)	Used for checking and adjusting the head gap
Adjustment knob (QY9-0031-000)	Used for adjusting the head gap
BJ cartridges (tester)	Prepare this as a special tool

You can substitute the above thickness gages, if not available, with commercially available ones capable of measuring 1.2 mm, 1.4 mm and 1.6 mm gaps.

#### 1. Checking the Head Gap

Follow the procedure below to check the head gap.

- 1) Remove the AC adapter, top case and sheet feeder unit from the printer, and make sure that the cartridge is locked. Attach both service BJ cartridges. Also, disconnect the CR motor connector from the logic board. If the carriage is moved manually with the CR motor still connected to the logic board, the electromotive force of the motor may damage the logic board.

- 2) Insert the measuring sheet into the manual paper feed slot. With the platen held down in position, align the left of the measuring sheet with the paper guides on the printer. Then, insert the measuring sheet until its leading edge is hooked on the spurs (see figure below) taking care not to deform the spurs.

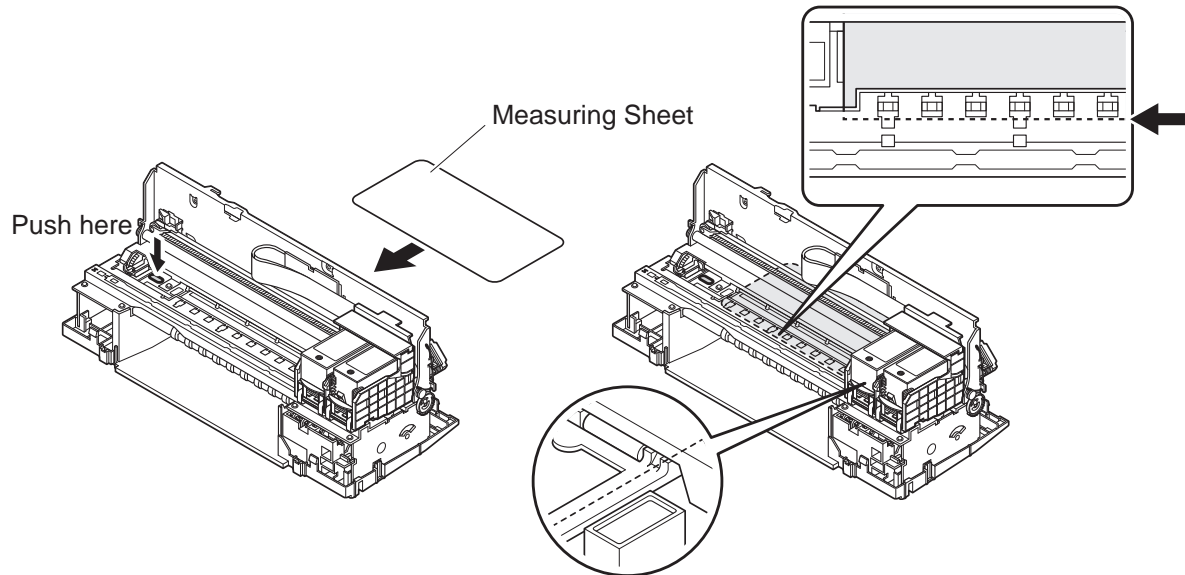

**Figure 5-10 Measuring Sheet Setting 1**

- 3) Gently press down on both ends of the platen, and then quickly release your hands. Repeat this two or three times to stabilize the platen position. Be sure to carry out this step. Otherwise, the head gap cannot be measured correctly.

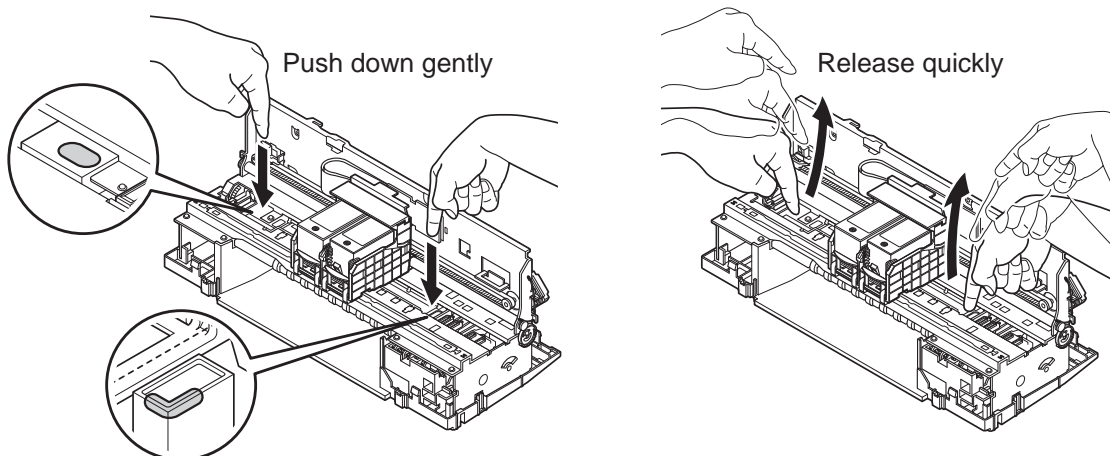

**Figure 5-11 Measuring Sheet Setting 2**

- 4) Place the thickness gage on the measuring sheet as shown in the figure below.

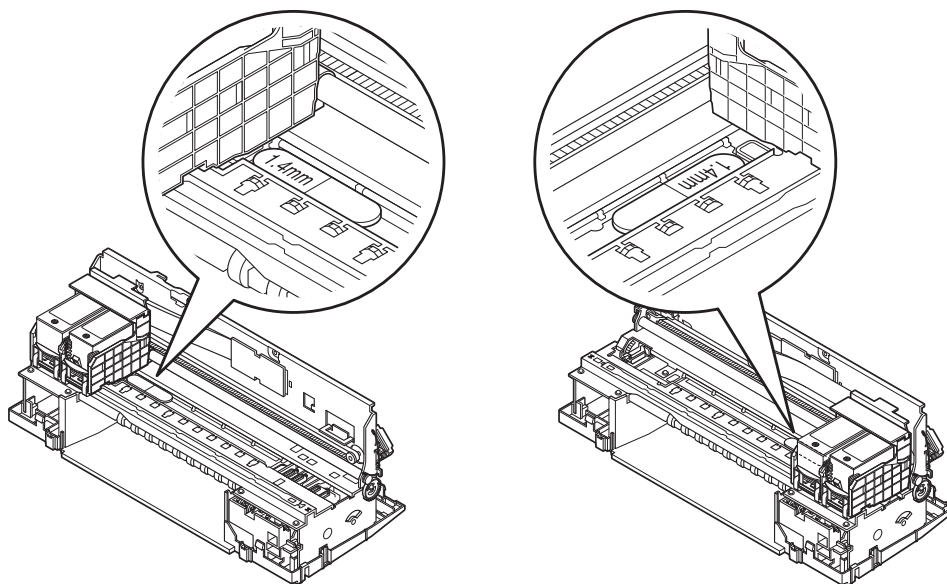

**Figure 5-12 Thickness Gauge Setting**

- 5) Move the carriage with your fingers gripping the carriage belt as shown in the figure below. Follow the flowchart on the following page for details on the checking order.

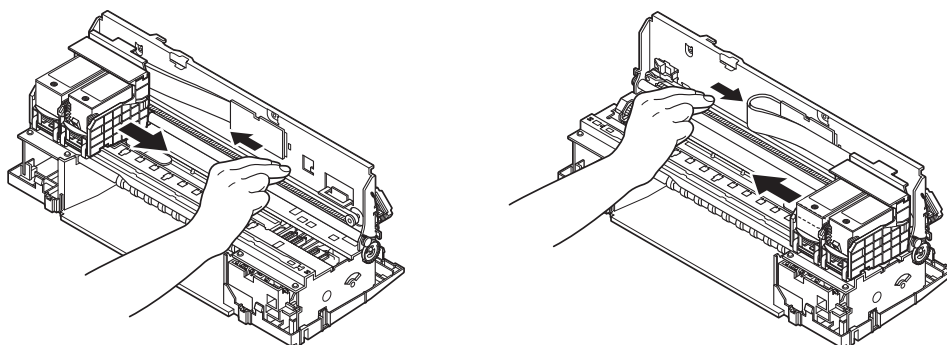
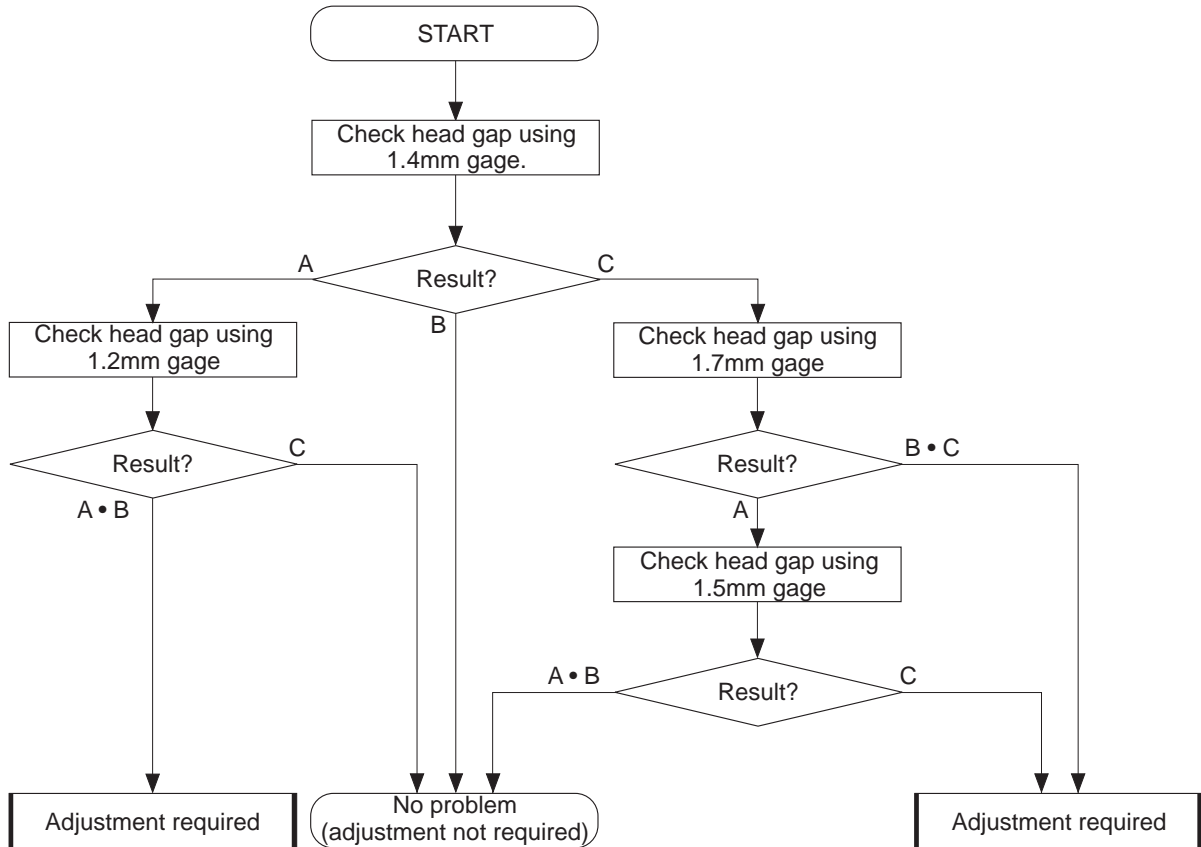

**Figure 5-13 Check the Head Gap**

**2. Head Gap Check/Adjustment Flowchart**

Check results are categorized into three types as follows:

- A: The head clearly contacts the thickness gage, and the thickness gage is moved pressed against the head.
- B: The head barely contacts the thickness gage, and the thickness gage moves very slightly.
- C: The head does not contact the thickness gage at all, and the thickness does not move at all.



**3. Adjusting the Head Gap**

Follow the procedure below to adjust the head gap if required.

- 1) Loosen the red screws, and turn the adjust plate so that the support shaft is at the topmost position.

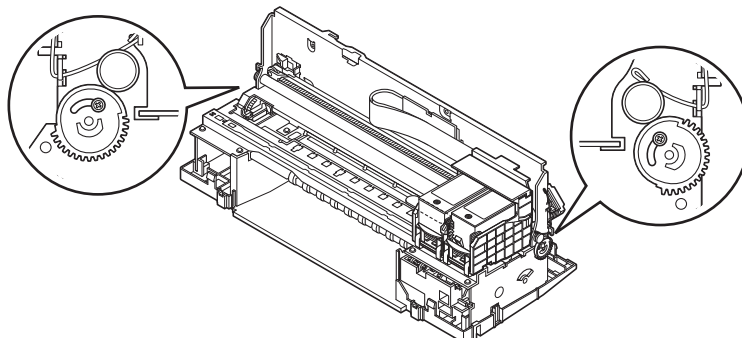

**Figure 5-14 Adjust the Head Gap 1**



- 2) Gently press down on both ends of the platen, and then quickly release your hands. Repeat this two or three times to stabilize the platen position. Be sure to carry out this step. Otherwise, the head gap cannot be measured correctly.
- 3) Place the 1.4 mm thickness gage on the measuring sheet.
- 4) Move the carriage with your fingers gripping the carriage belt as shown in the figure below. Turn the adjust plate a little at a time by the adjustment knob as you move the carriage to the left and right. Adjust the adjust plate so that the BJ Head barely contacts the thickness gage, and then temporarily tighten the red screws.

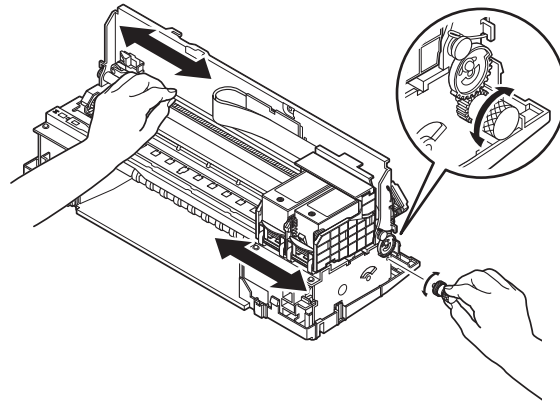

**Figure 5-15 Adjust the Head Gap 2**

- 5) Repeat the above procedure three times alternately on the left and right ends. Last of all, firmly tighten the red screws to fix the adjust plate in place.



## 6. TROUBLESHOOTING

### 6.1 Troubleshooting Overview

#### 6.1.1 Overview

This chapter consists of the following two sections: "Diagnosis" and "Action."

If you do not know the cause of a problem, consult the "Diagnosis" section. If you do know the cause, follow the instructions in the "Action" section.

#### 6.1.2 Troubleshooting cautions

1. Before starting diagnostic procedures, check that all connectors and cables are correctly connected. This is especially important if faults occur randomly.
2. If you are diagnosing faults with the printer covers removed and the AC adaptor connected, be extremely careful to avoid electric shock to prevent shorting the boards.
3. Follow the flowcharts when troubleshooting.
4. When diagnosing faults concerning print quality and paper feed, first check that

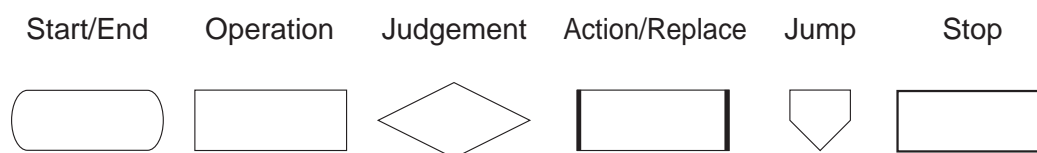

the installation location and print media satisfy the specifications, that the print media is loaded correctly, and that the printer driver parameters are set correctly, etc.

5. If you replace or service a part, be sure to make a test print to check that the fault has been remedied.
6. The flowcharts may indicate a number of possible actions to be taken in troubleshooting and correcting a fault. These actions are indicated in the order required to remedy the problem.  
After each step, make a test print to see if the fault has been corrected and, if not, proceed to the next step.

#### Example 1

Countermeasure 1: After checking or replacing the carriage cable, make a test print to check that the printer is functioning normally.

If the fault is not corrected, advance to step 2, "Replace carriage unit", and if the problem is still not corrected, go to step 3, "Replace logic board."

7. On completion of troubleshooting, check that you have reconnected all connectors

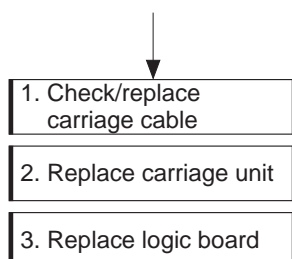

and tightened any loosened screws, etc.

## 6.2 Diagnosis

### 6.2.1 Diagnostic flow

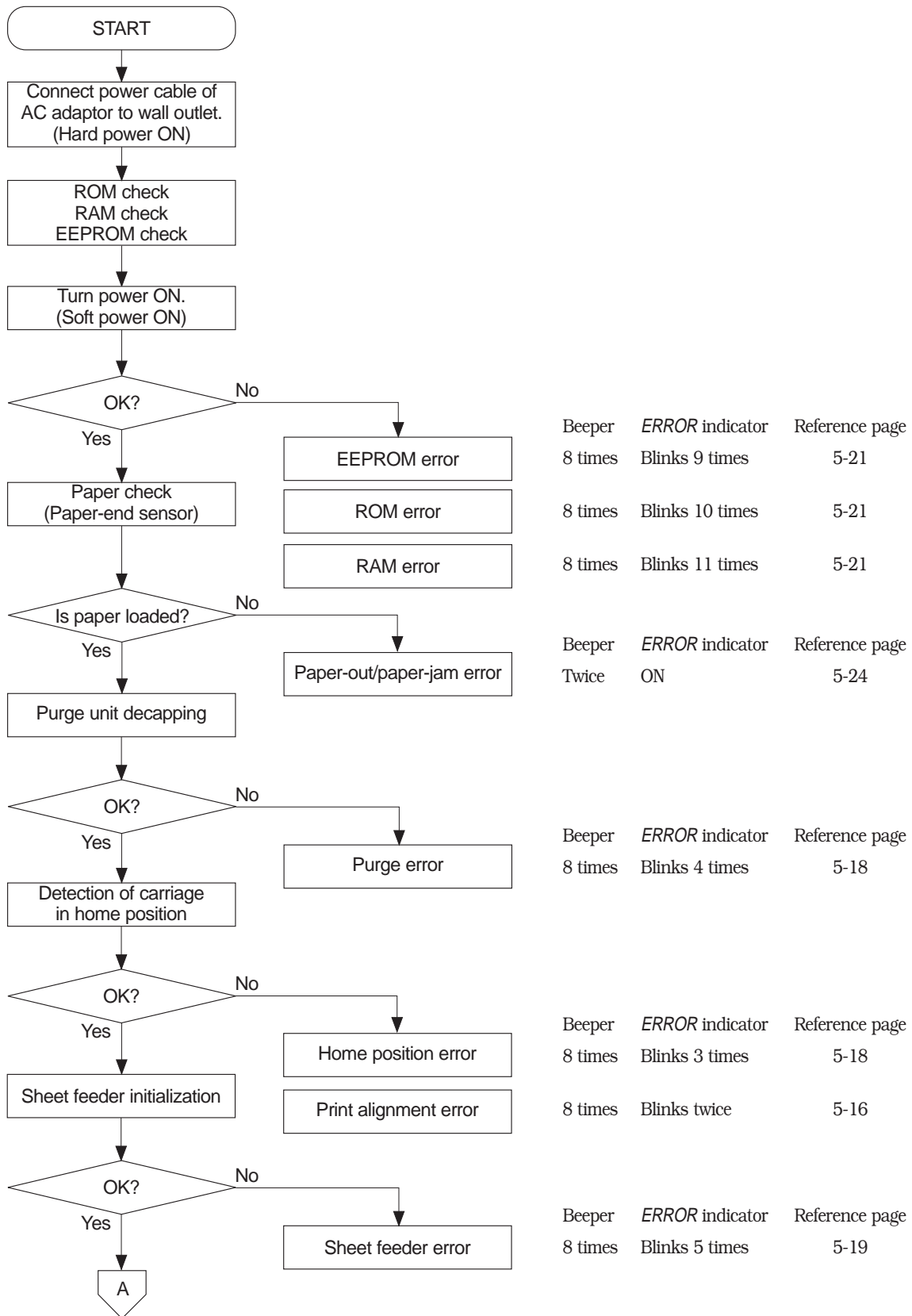

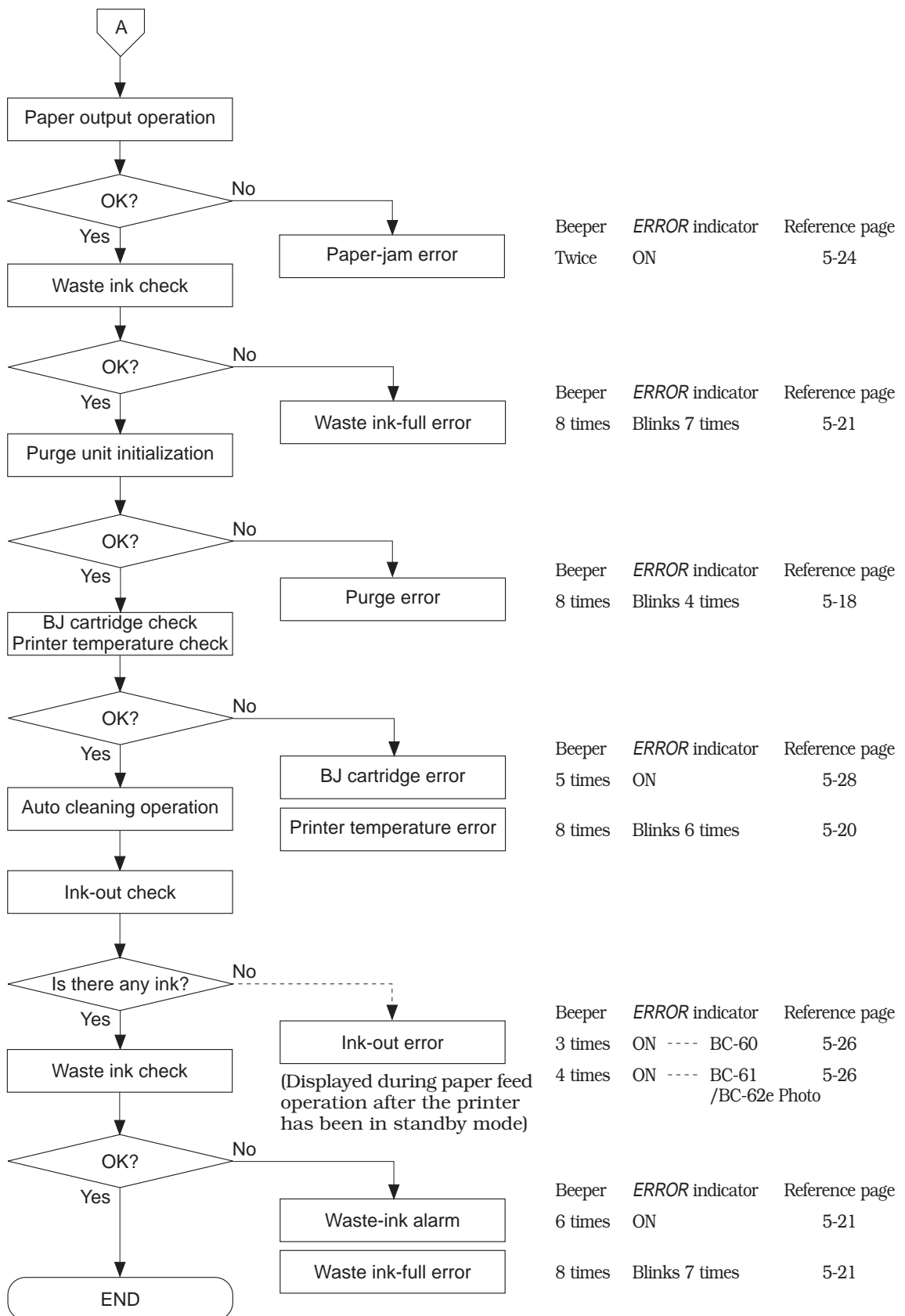

6.2.2 Action

a) Error displays

1. Print Position Correction Error

Buzzer: 8 times  
 ERROR indicator: Blinks twice

**<Cause>** During initialization, the carriage print position is not corrected. (The differential between the carriage travel in each direction is outside the correction range.)

**<Suspected parts>** Carriage unit, carriage belt, carriage cable, carriage shaft, guide rail, idler pulley, logic board

**<Measure>**

Visually check carriage drive.

OK?

- Check for paper jams, wear and tear and removal of carriage belt;
- Carriage with faulty idler pulley assembly operation;
- Carriage shaft distortion, scratches, insufficient lubrication, etc.
- Does the carriage move smoothly when moved manually?  
 See "4. 2. 2 Carriage unit" (page 5-4) for how to release the carriage lock.

Service or replace faulty part.

Reconnect power supply.

Check operation of carriage drive.

OK?

- Does the carriage motor run during initialization?
- Is the carriage drive out of sync?
- Are there any problems in the carriage belt or idler pulley?
- Are there any abnormal noises?

A

\*: See "CAUTION" on page 1-14.

Measuring point	Sensor	Normal value
IC1 (MPU)	Open	Low level
Pin No. 28	Closed	High level (sensing)

Check home position sensor.

OK?

- Check the measuring point while manually moving the carriage with the power ON. (This is easier with the sheet feeder removed.)

Replace logic board.

- Faulty MPU
- Faulty PCB soldering/conductivity

Check carriage cable conductivity.

Measuring point  
 Carriage ribbon cable (28pin)  
 Pin Nos. 6 and 7

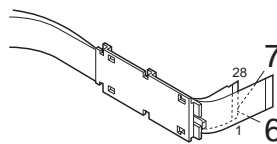

OK?

Replace carriage unit.

- Faulty carriage board.

Replace carriage cable.

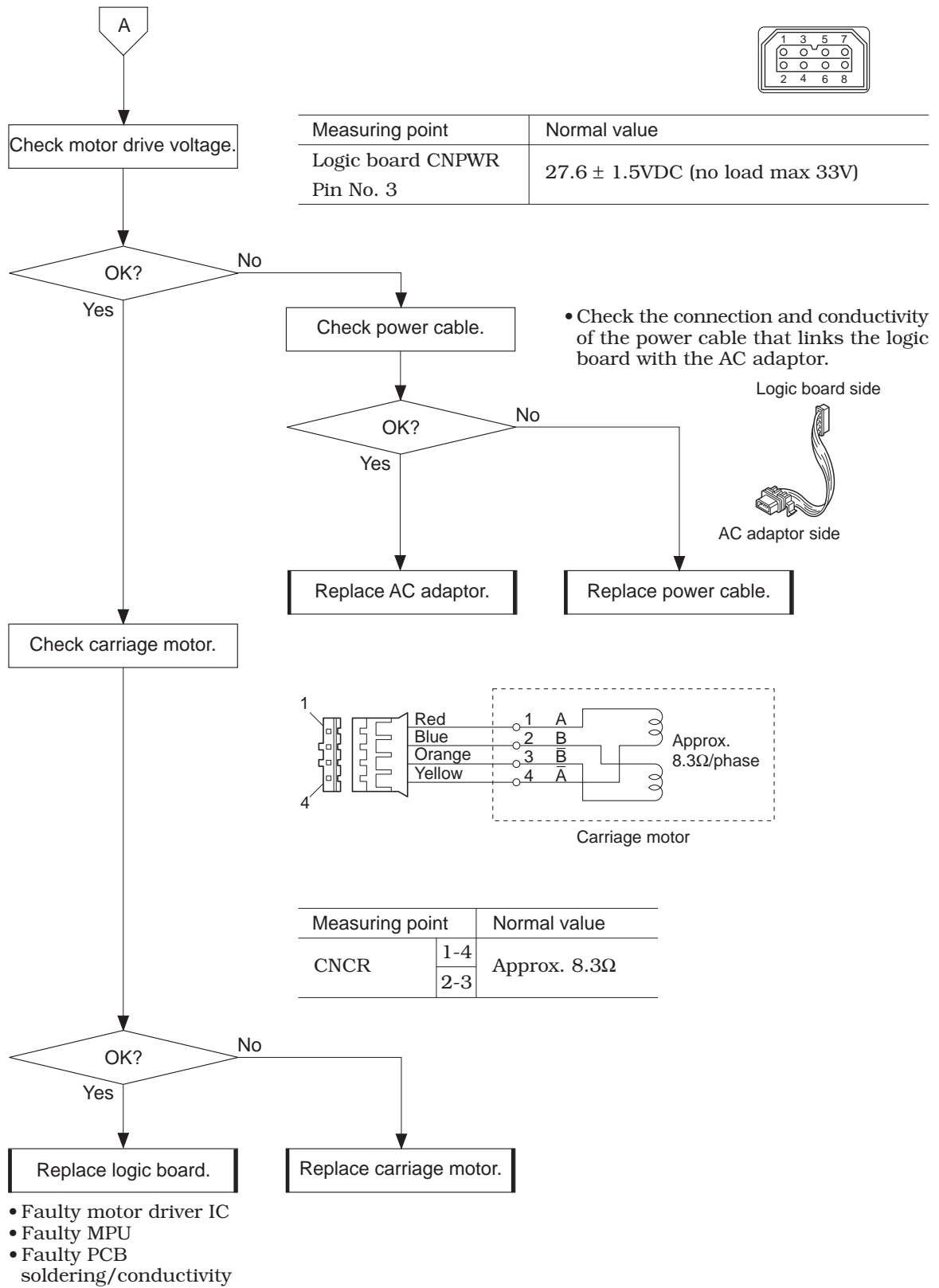

## 2. Home Position Error

**<Cause>** Cannot detect home position.

**<Suspected parts>** Carriage unit, carriage belt, carriage cable, carriage shaft, guide rail, idler pulley, logic board

Beeper: 8 times

ERROR indicator: Blinks 3 times

**<Measure>** 1. See Print Position Correction Error (page 5-17).

## 3. Purge Error

**<Cause>** Cleaning not performed normally.

**<Suspected parts>** Purge unit, purge sensor, purge sensor cable, paper feed motor drive transmission gear, logic board

Beeper: 8 times

ERROR indicator: Blinks 4 times

**<Measure>**

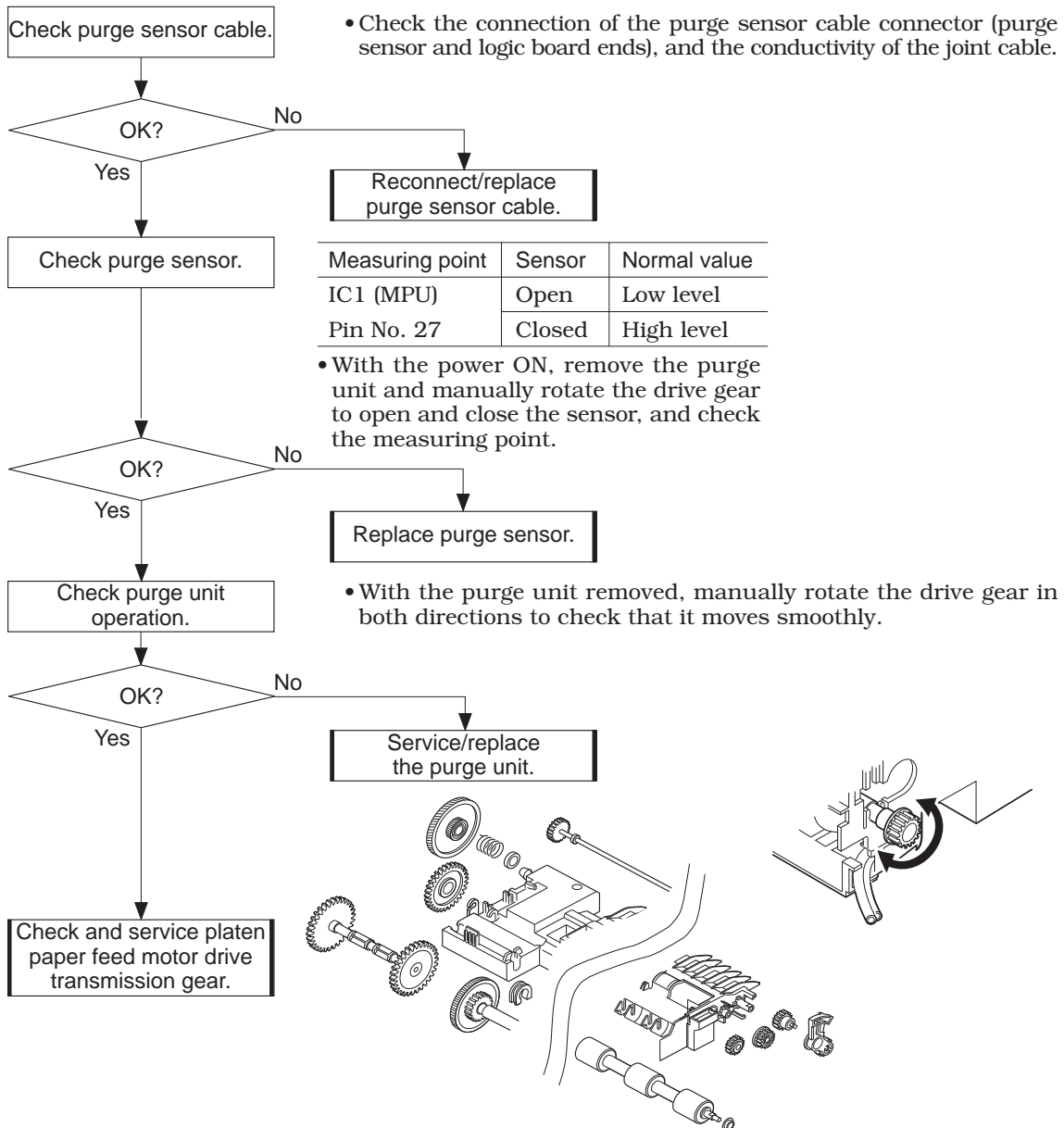

# 4. Sheet Feeder Error

Beeper: 8 times  
 ERROR indicator: Blinks 5 times

**<Cause>** Sheet feeder not initialized during printer initialization.  
**<Suspected parts>** Sheet feeder unit, pickup roller, sheet feeder drive gear, paper feed motor drive transmission gear, slide lock lever, logic board

**<Measure>**

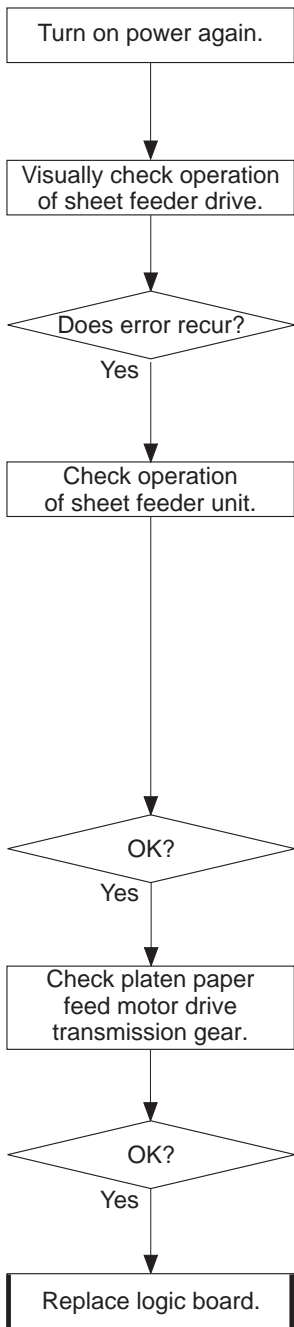

- Check the movements of the parts (gears, etc.) inside the sheet feeder.

Turn the power on and off several times, and quit if the error does not recur.

- Remove the sheet feeder unit and manually rotate the drive gears to check that the pickup roller, etc., operates correctly and smoothly.

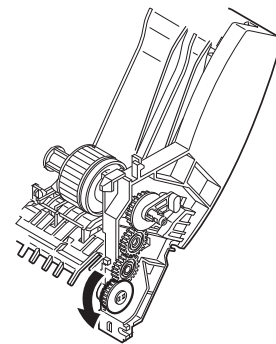

Service/replace faulty parts.

- Visually check the appearance and operation of the paper feed rollers and power switching gears, which transmit the power of the paper feed motor.
- Simultaneously check the operation of the purge unit's slide lock lever, which locks the power switching unit.

Service/replace faulty parts.

Replace logic board.

- Faulty pickup roller sensor
- Faulty MPU
- Faulty PCB soldering/conductivity

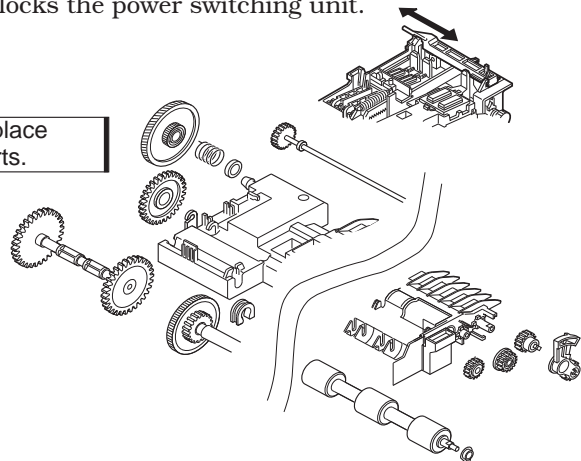

# 5. Printer Temperature Error

**<Cause>** Thermistor (TH1) on carriage board detects higher than prescribed temperature limit.  
**<Suspected parts>** Carriage unit, carriage cable, logic board

Beeper: 8 times  
 ERROR indicator: Blinks 6 times

**<Measure>**

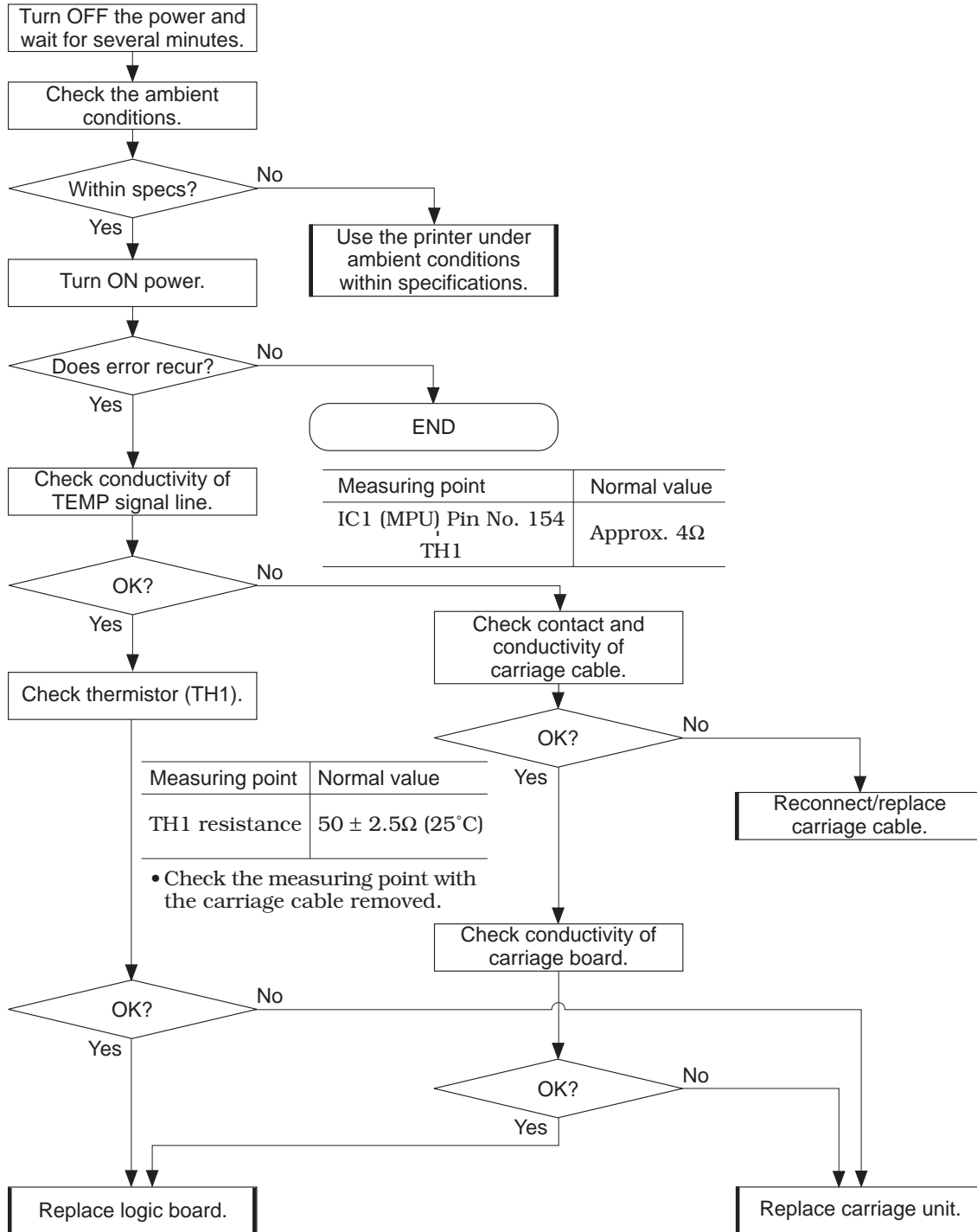

- Faulty MPU
- Faulty PCB soldering/conductivity



### 6. Waste Ink Alarm/Full Error

Beeper: 6 times  
ERROR indicator: ON (alarm)  
Beeper: 8 times  
ERROR indicator: Blinks 7 times (full error)

**<Cause>** The waste ink absorbers are 95% full (alarm) or 100% full (full error).  
**<Suspected parts>** Waste ink absorbers, logic board (EEPROM)

**<Measure>**

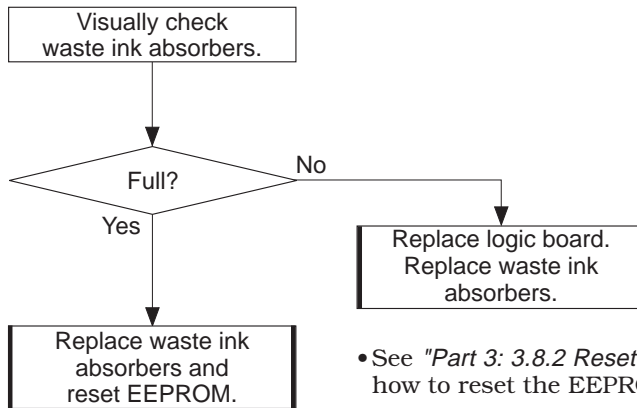

- There is a risk of the EEPROM data being incorrect. If you replace the Logic Board, also replace the waste ink absorbers.
- See "Part 3: 3.8.2 Resetting EEPROM data" (page 3-22) for details of how to reset the EEPROM.

### 7. EEPROM Error

Beeper: 8 times  
ERROR indicator: Blinks 9 times

**<Cause>** Contents of EEPROM cannot be read correctly during initial check.  
**<Suspected parts>** EEPROM (IC7) and logic board.

**<Measure>** Replace the logic board and waste ink absorbers (including the maintenance jet absorbers).

### 8. ROM Error

Beeper: 8 times  
ERROR indicator: Blinks 10 times

**<Cause>** Contents of control ROM (IC3) cannot be read normally during initial check.  
**<Suspected parts>** Control ROM (IC3) and logic board.

**<Measure>** Replace the control ROM (IC3), or logic board.

### 9. RAM Error

Beeper: 8 times  
ERROR indicator: Blinks 11 times

**<Cause>** Read/writing to DRAMs (IC5 and IC6) was not normal during initial check.  
**<Suspected parts>** DRAMs (IC5 and IC6) and logic board.

**<Measure>** Replace the logic board.

## 10. CR Motor Error

**<Cause>** Overheating of carriage motor driver (IC13)  
**<Suspected parts>** Carriage motor driver (IC13), logic board, carriage motor

Beeper: 8 times

ERROR indicator: Blinks 12 times

### <Measure>

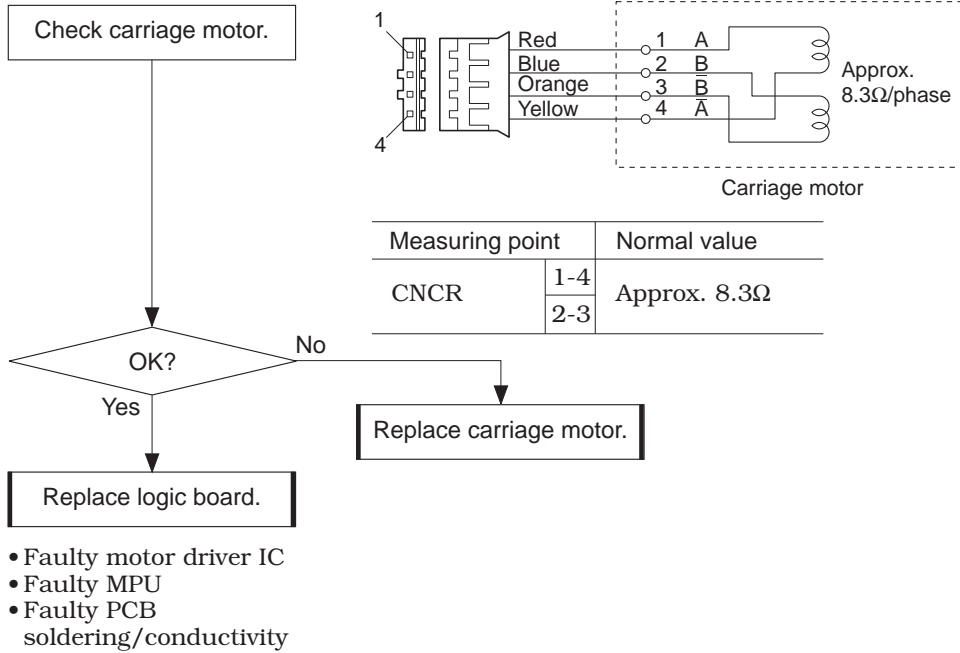

## 11. LF Motor Error

**<Cause>** Overheating of paper feed motor driver (IC14)  
**<Suspected parts>** Paper feed motor driver (IC14), logic board, paper feed motor

Beeper: 8 times

ERROR indicator: Blinks 13 times

### <Measure>

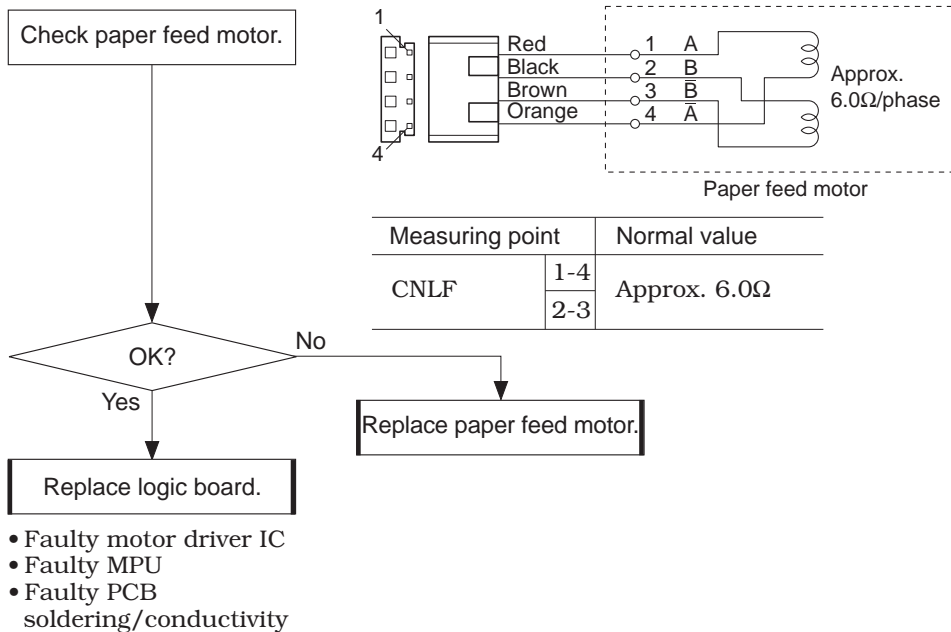

## 12. Miscellaneous Hardware Errors

Beeper: 8 times

ERROR indicator: Blinks 14 times

- <Cause>**
1. Error detected by paper feed sensor or purge sensor during paper transport (other than pickup or during initialization).
  2. When the printer is idle, the head temperature sensor has detected an overheat.

- <Suspected parts>**
1. Paper feed motor drive switching mechanism, slide lock lever
  2. Carriage unit, BJ cartridge

- <Measure>**
1. When error occurs during transport operation:  
Check and service or replace the paper feed motor drive switching mechanism and slide lock lever.

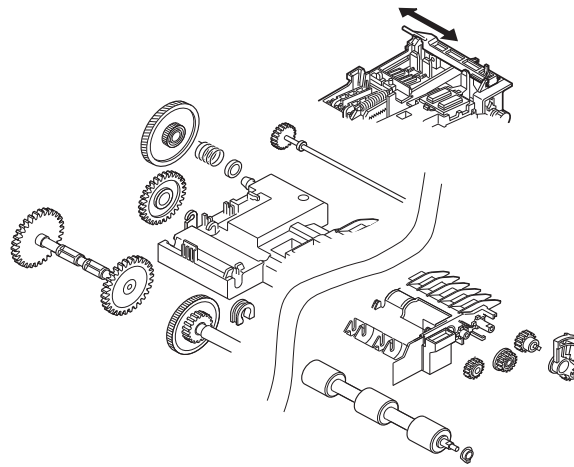

2. When error occurs when the printer is idle:  
Check and service or replace the BJ cartridge and carriage unit.  
(Carefully check for dried ink and shorting of the BJ cartridge contacts.)

# 13. Paper-out and Paper-jam Errors

Beeper: 2 times  
 ERROR indicator: ON  
 POWER indicator: Blinks

- <Cause>** 1. No print media is picked up in pickup operation.  
 2. No print media is output in paper output operation.

**<Suspected parts>** Sheet feeder unit, paper edge guide, pressure roller and holder, platen, feed roller, paper output roller, transfer roller, paper output unit, paper end sensor, logic board

**<Measure>** 1. Pickup error

Check the type of loaded print media, the method by which loaded, and the printer's ambient conditions.

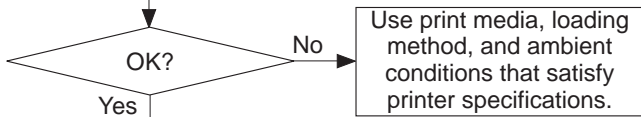

Turn power ON again and make test print.

Check operation of paper feed mechanism and feed status.

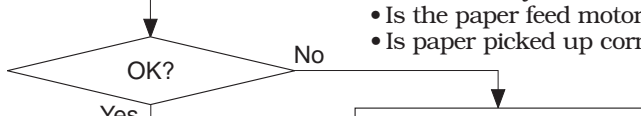

Check sheet feeder unit.

- Remove the sheet feeder unit and check its operation manually.
- Check for abnormal soiling or deterioration of feed roller rubber and separation sheet. (Wipe away paper dust, etc., with ethanol to restore the ability to pick up the paper.)
- Check for deformation, damage, and insufficient lubrication of the gears.
- Check that the separation hooks operate smoothly. (Check especially when thick sheets, postcards, and high-gloss papers are not picked up.)

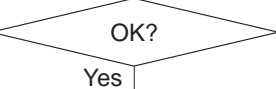
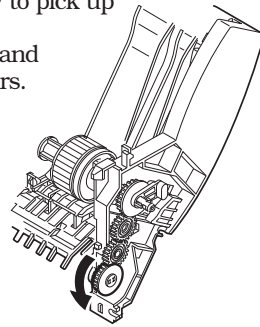

Service or replace faulty parts.

- Check also the operation of the purge unit's slide lock lever.

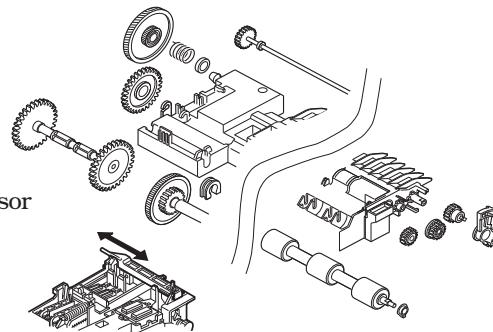

- Faulty pickup roller sensor
- Faulty MPU
- Faulty PCB soldering/ conductivity

2. Paper jam

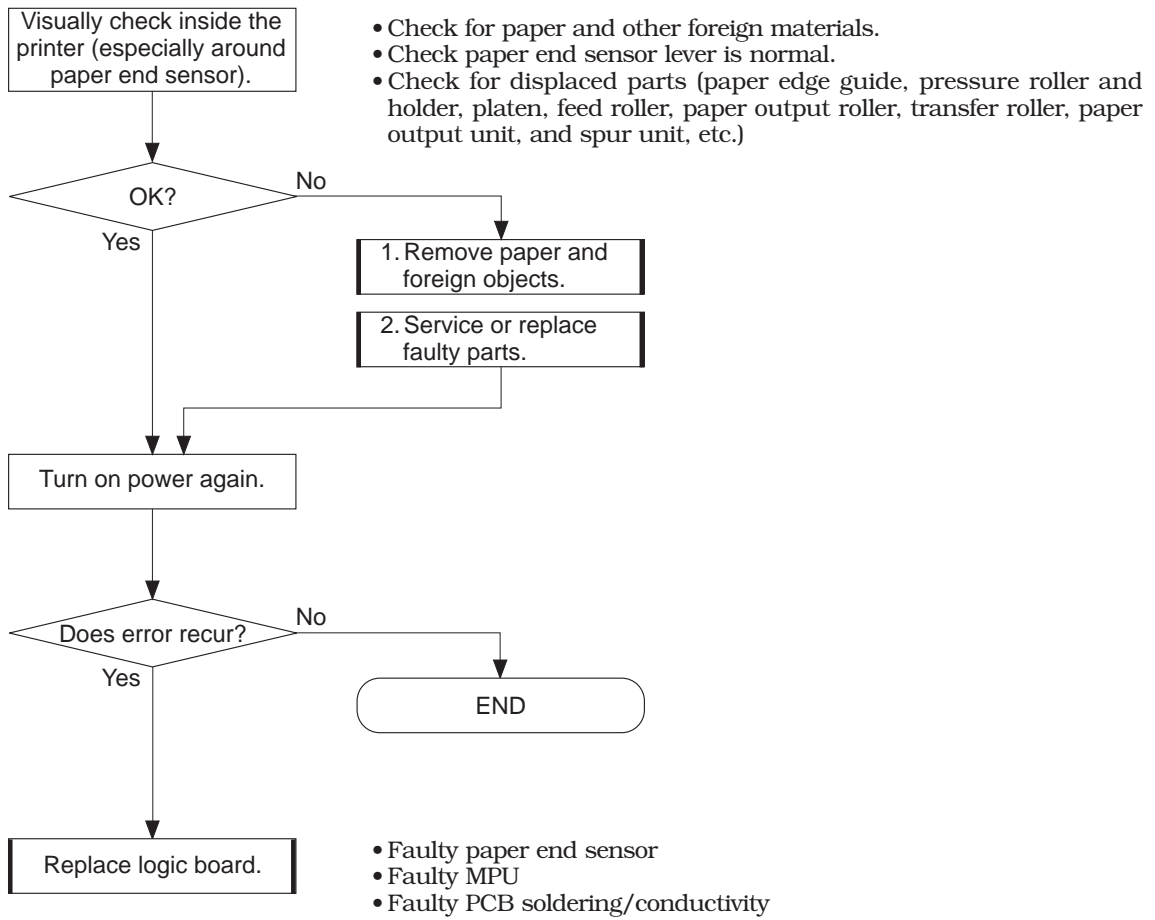

# 14. Ink-out Error

- <Cause>**
1. No ink in BJ cartridge BC-60.
  2. No ink in color BJ cartridge BC-61.
  3. No ink in Photo BJ cartridge BC-62e Photo.

Beeper: 3 times (BJ cartridge BC-60)  
 Beeper: 4 times (Color BJ cartridge BC-61 or Photo BJ cartridge BC-62e Photo)

**<Suspected parts>** BJ cartridge, ink tank, antenna, carriage unit, logic board, front cover, main cover

**ERROR** indicator: ON  
**POWER** indicator: Blinks

**<Measure>** 1. BJ cartridge BC-60

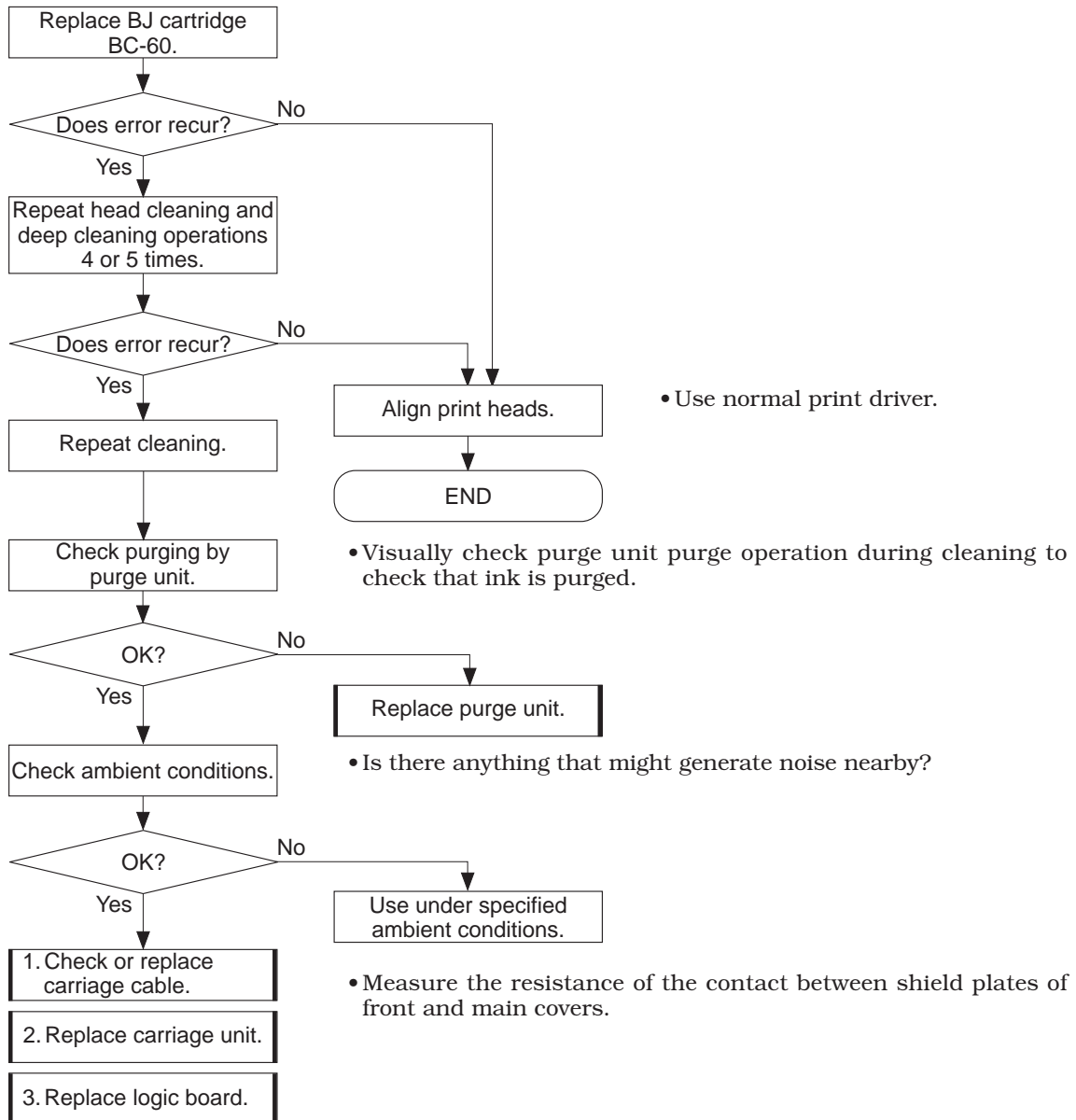

2. Color BJ cartridge BC-61  
Photo BJ cartridge BC-62e Photo

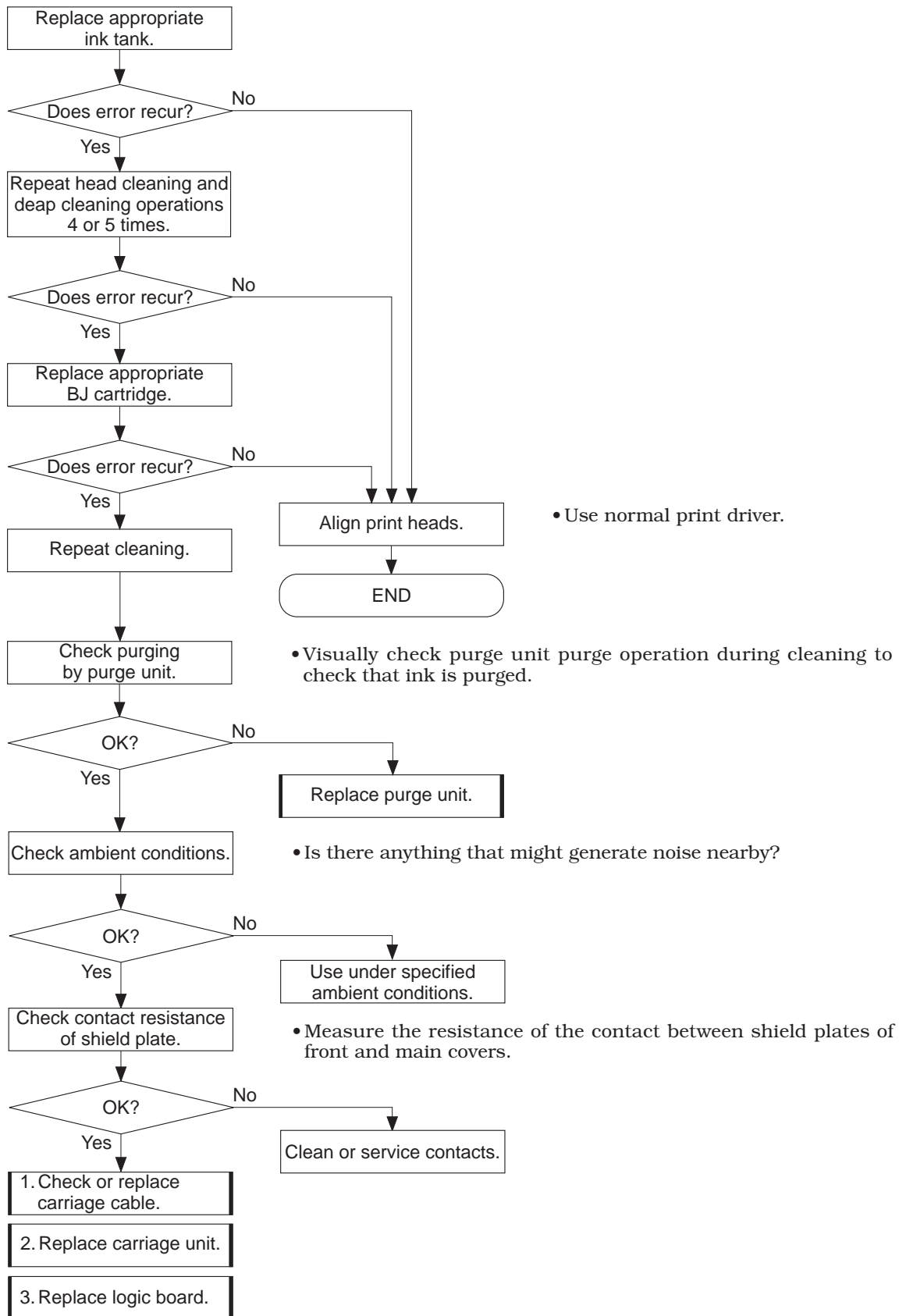

# 15. BJ Cartridge Error

Beeper: 5 times  
 ERROR indicator: ON  
 POWER indicator: Blinks

- <Cause>**
1. Error detected in BJ cartridge type ID.
  2. Error detected in head rank resistance.
  3. Error detected in head temperature sensor resistance.
  4. Head sub-heaters not controlled normally.

**<Suspected parts>** BJ cartridge, color BJ cartridge, photo BJ cartridge, carriage unit, carriage cable, logic board

**<Measure>**

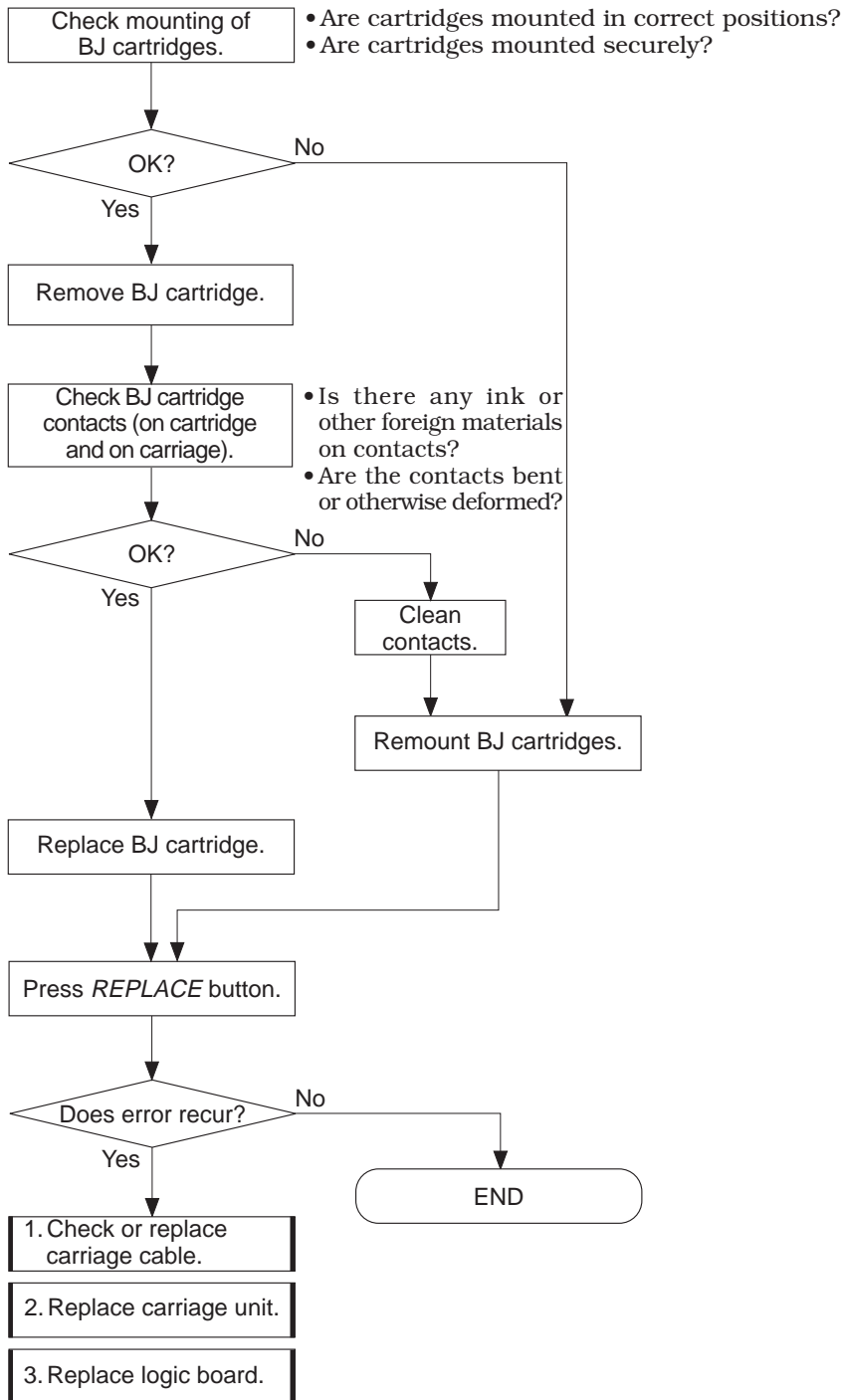



## 16. BJ Cartridge Overheat Error

**<Cause>** With ink in BJ cartridge, head temperature sensor detects overheat.

**<Suspected parts>** BJ cartridge

Beeper: 7 times

*ERROR* indicator: ON

*POWER* indicator: Blinks

**<Measure>** Wait several minutes with power OFF, then turn power ON again. If the error recurs, follow the procedure in [15. BJ Cartridge Error](#) .

**b) Symptoms**

**1. The power does not turn on**

- <Symptoms>**
- The power does not turn on even when the *POWER* button is pressed.
  - When the power is turned ON, the printer operates abnormally.

**<Cause>** Faulty AC adaptor or AC adaptor not installed correctly, faulty logic board, faulty control panel (*POWER* button), faulty power cable

**<Measure>**

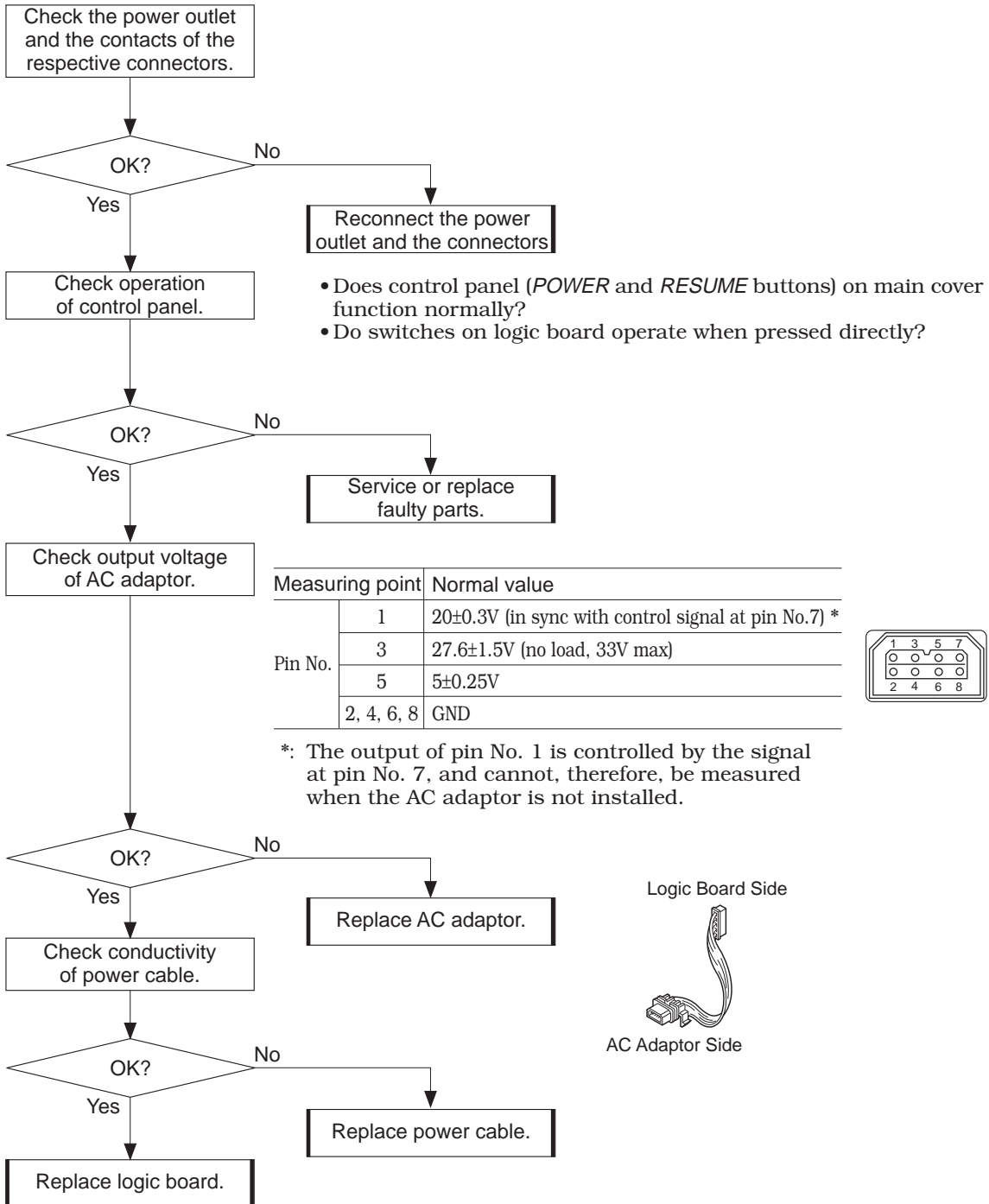

## 2. Abnormal noise

- <Symptoms>**
- Noise during carriage drive.
  - Noise during purge drive.
  - Noise during pickup, paper output, and paper transport

- <Cause>**
- Foreign object in, damage to, or misplacement of carriage drive mechanism.
  - Carriage (including BJ cartridges) interfering with other parts.
  - Faulty idler pulley.
  - Faulty purge unit.
  - Faulty paper feed motor drive transfer gear.
  - Faulty sheet feeder unit.
  - Insufficient lubrication (grease).

- <Measure>**
- Noise in carriage drive  
Manually move carriage left and right to check and service part by which noise is generated.
  - Noise in purge drive

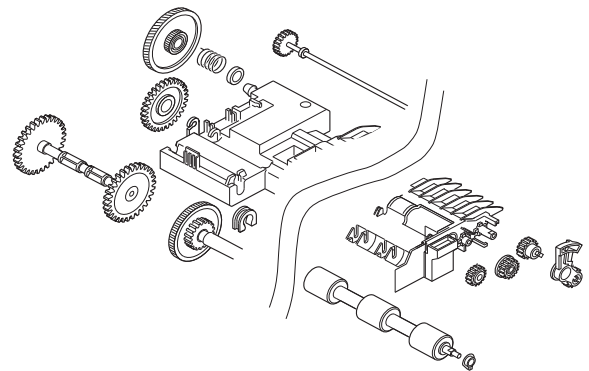
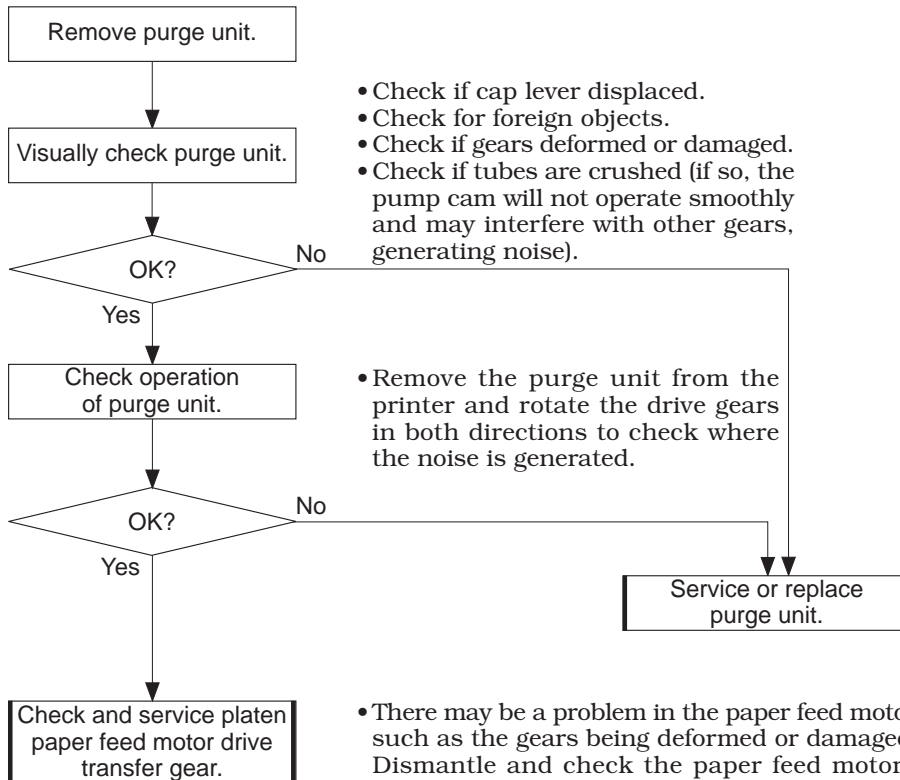

• Noise during pickup, paper output, and paper transport

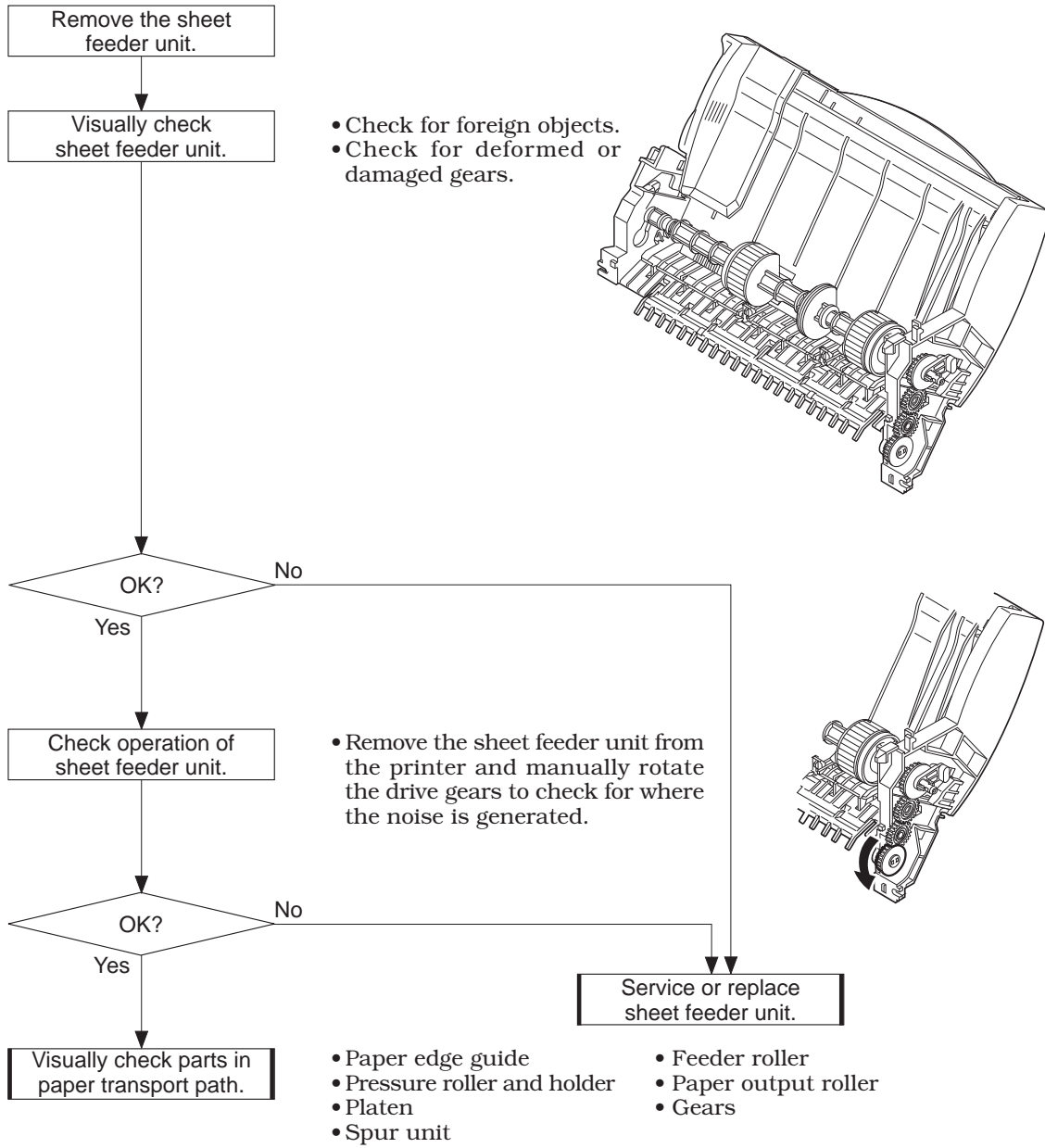

### 3. Faulty pickup

- <Symptoms>**
- Paper not picked up, or multiple pages picked up
  - Paper skewed or not output
  - Frequent paper jams

- <Cause>**
- Faulty sheet feeder unit
  - Faulty paper edge guide, platen, feed roller, spur unit, pinch roller and holder, paper output roller, transmission roller parts
  - Faulty paper feed motor
  - Faulty paper output unit
  - Faulty sensor lever
  - Small pieces of paper or other foreign objects in the mechanism

**<Measure>**

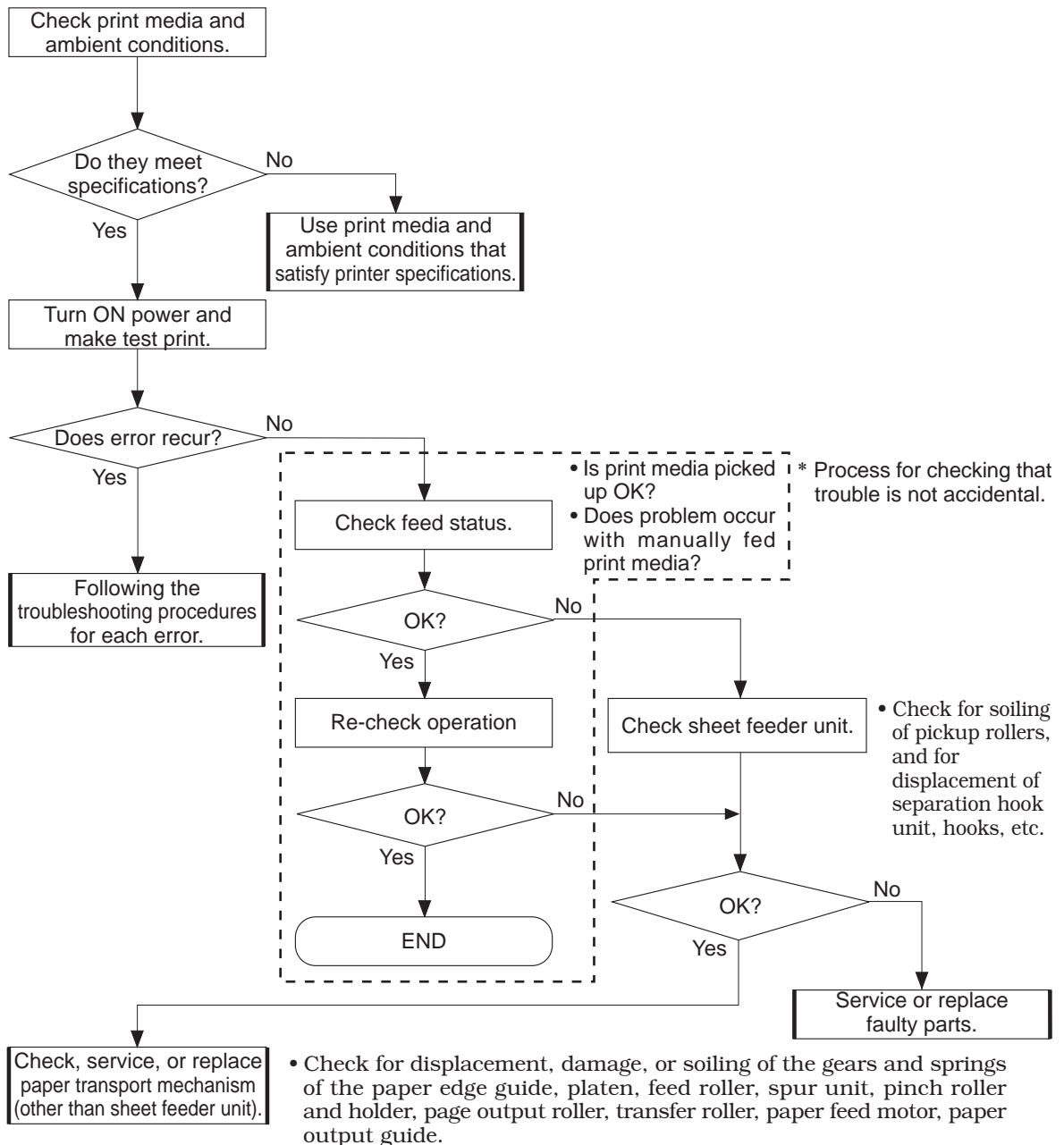

**4. Faulty printing <1>:  
No printing**

- <Symptoms>**
- The printer does not print at all.
  - Printing stops mid-way.
  - Only a certain color is printed.
- <Cause>**
- The ink has run out or the BJ cartridge is faulty.
  - The carriage unit is faulty, the carriage cable is faulty, the purge unit is faulty, or the logic board is faulty.

**<Measure>**

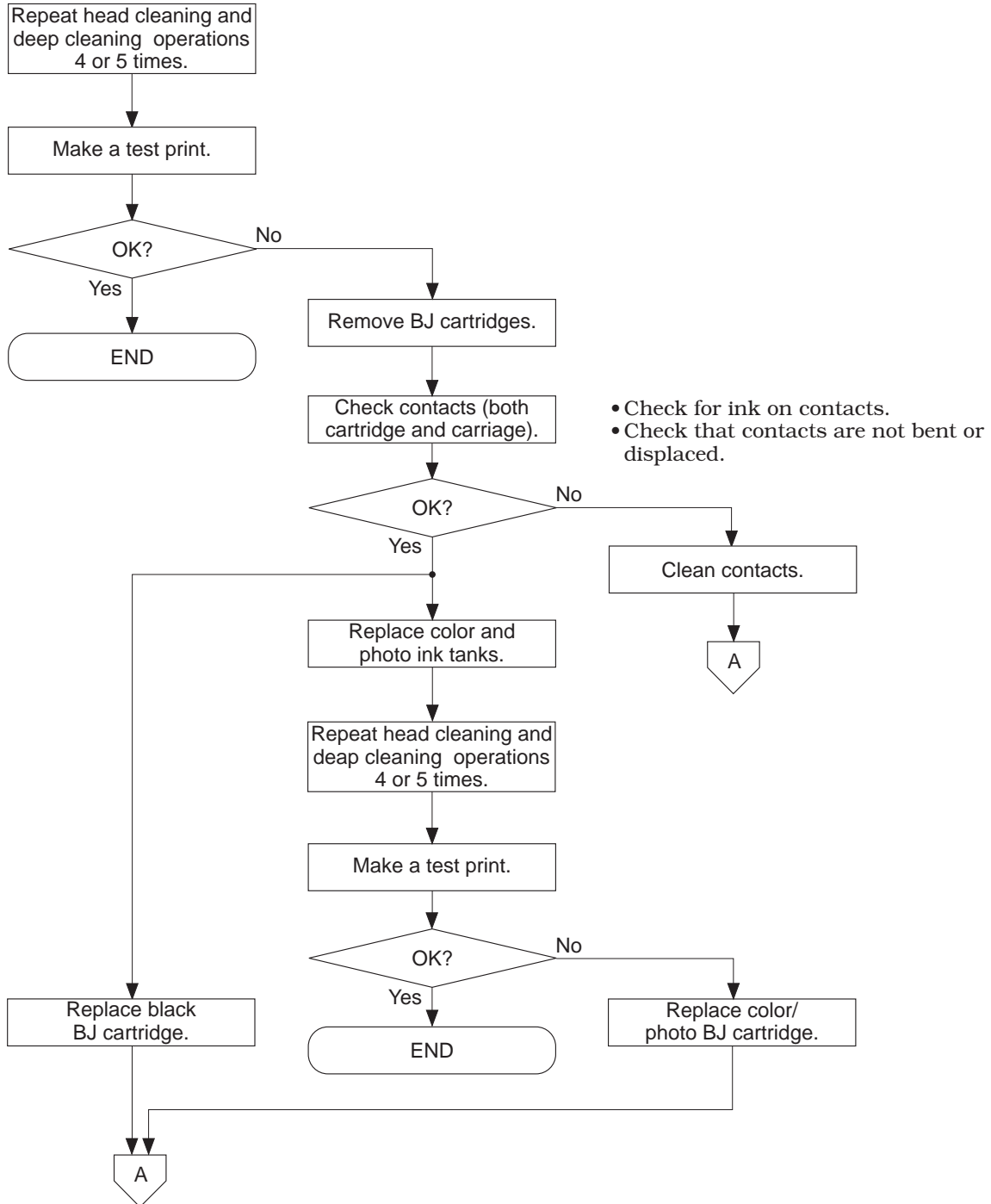

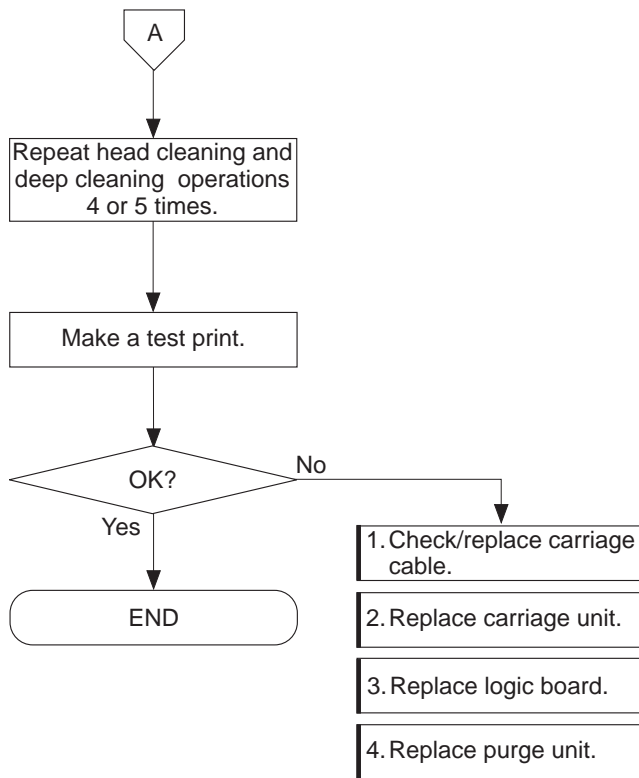

## 5. Faulty printing <2>: Miscellaneous problems

Symptoms	Cause	Measure
<ul style="list-style-type: none"> <li>• White stripes (horizontal)</li> <li>• Blotching</li> </ul>	Insufficient cleaning, ink-out, faulty BJ cartridge	Perform several cleaning operations, then make test print. Replace BJ cartridge(s) or ink tank(s).
	Faulty cleaning operation	Replace purge unit.
<ul style="list-style-type: none"> <li>• Spur tracks (vertical)</li> </ul>	Faulty spurs (soiled or deformed)	Replace spurs, spur cleaner, or spur unit.
<ul style="list-style-type: none"> <li>• Color dropout</li> </ul>	Incorrect print driver setting	Select FINE mode* using printer driver, or select error dispersal.
	Insufficient cleaning, ink-out, faulty BJ cartridge	Perform several cleaning operations, then make test print. Replace BJ cartridge(s) or ink tank(s).
<ul style="list-style-type: none"> <li>• Ink bleeds</li> </ul>	Incorrect print driver setting	Select FINE mode* using printer driver, or set color parameter lighter.
	Incorrect paper (print media)	Change to higher quality print media.
	No jetting of ink optimizer (plain paper)	Perform several cleaning operations, then make test print. (Check nozzles on transparency.) Replace black BJ cartridge (BC-60).
<ul style="list-style-type: none"> <li>• Impure color or mixed colors</li> </ul>	Insufficient cleaning, ink-out, faulty BJ cartridge	Perform several cleaning operations, then make test print. Replace BJ cartridge(s) or ink tank(s).
	Insufficient cleaning	Replace purge unit.
<ul style="list-style-type: none"> <li>• Displaced borders</li> </ul>	Heads not aligned	Use printer driver to align print heads.
	Faulty BJ cartridge	Perform several cleaning operations, then make test print. Replace BJ cartridge(s).
<ul style="list-style-type: none"> <li>• Dirty print media</li> </ul>	Dirty inside printer (ink mist or paper dust, etc.)	Visually check, and clean, inside printer.
	Ink has dried or foreign objects adhering to head face	Perform several cleaning operations, then make test print. Replace BJ cartridge(s).
	Dirty purge unit or wiper unit	Replace purge unit, cleaner unit, wiper unit.
	Printing onto platen (incorrect driver setting)	Set the correct paper size in the printer driver.
<ul style="list-style-type: none"> <li>• Deformed characters</li> </ul>	Incorrect printer driver setting	Select BJC-7100 printer driver.
	Remaining data	Turn ON power again.
	Faulty interface cable or faulty logic board	Check in hexadecimal dump mode and service or replace faulty part(s).

\*FINE mode: default setting of Auto mode



## 7. CONNECTOR LAYOUT AND SIGNAL ASSIGNMENT

### 7.1 Logic Board

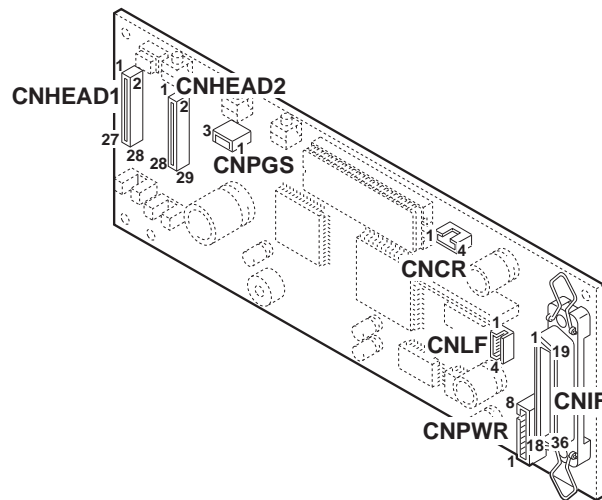

Figure 5-16 Logic Board

#### CNPWR (Connection to AC Adaptor)

Pin No.	Signal	IN/OUT	Function
1	VH	IN	Head drive voltage ( $20.0 \pm 0.3\text{VDC}$ )
2	VH-GND	...	VH GND
3	VM	...	Motor drive voltage ( $27.6 \pm 1.5\text{VDC}$ )
4	VM-GND	IN	VM GND
5	VCC	...	Logic drive voltage ( $5.0 \pm 0.25\text{VDC}$ )
6	VCC-GND	IN	VCC GND
7	VHON	OUT	VH output control
8	GND	...	GND

#### CNPGS (Purge Sensor Connector)

Pin No.	Signal	IN/OUT	Function
1	LEDON	OUT	Photointerruptor LED drive voltage
2	GND	...	GND
3	PGS	IN	Purge unit module initial phase detection

#### CNCR (Carriage Motor Connector)

Pin No.	Signal	IN/OUT	Function
1	CRA	OUT	A-phase drive voltage
2	CRB	OUT	B-phase drive voltage
3	$\overline{\text{CRB}}$	OUT	$\overline{\text{B}}$ -phase drive voltage
4	$\overline{\text{CRA}}$	OUT	$\overline{\text{A}}$ -phase drive voltage

#### CNLNF (Paper Feed Motor Connector)

Pin No.	Signal	IN/OUT	Function
1	LFA	OUT	A-phase drive voltage
2	LFB	OUT	B-phase drive voltage
3	$\overline{\text{LFB}}$	OUT	$\overline{\text{B}}$ -phase drive voltage
4	$\overline{\text{LFA}}$	OUT	$\overline{\text{A}}$ -phase drive voltage

**CNIF (Parallel Interface Connector)**

See "Part 2: 2.3 Interface Specifications" (page 2-12).

**CNHEAD1 (Carriage Cable Connector)**

Pin No.	Signal	IN/OUT	Function
1	TSKOM	IN	Ink optimizer temperature sensor (diode) output voltage
2	TSKBK	IN	Black head temperature sensor (diode) output voltage
3	LTCLK	OUT	Print data latch timing specification
4	RANKOM	IN	Ink optimizer rank resistance detection
5	RANKBK	IN	Black head rank resistance detection
6	IDATAOM	OUT	Ink optimizer print data
7	IDATABK	OUT	Black head print data
8	HEATEOM	OUT	Ink optimizer heat enable
9	HEATEBK	OUT	Black head heat enable
10	ID1OM/ELCPH	IN/OUT	Ink optimizer head index1 detection/photo head cyan ink-out detection pulse (ID1OM input and ELCPH output)
11	DCLK	OUT	Print data transfer clock
12	ID1BK/ELBK	IN/OUT	Black head index1 detection/ink-out detection pulse (ID1BK input and ELBK output)
13	SUBHOM	OUT	Ink optimizer sub-heater drive
14	BE1	OUT	Print data block output signal generation 2
15	SUBHBK	OUT	Black head sub-heater drive
16	ID2OM/ELOM	IN/OUT	Ink optimizer index 2 detection/ink-out detection pulse (ID2OM input and ELOM output)
17	EVENE	OUT	Black head and color head odd nozzle, and ink optimizer and photo head even nozzle heat enable
18	ID2BK/ELYCL	IN/OUT	Black head index 2 detection/color head yellow ink-out detection pulse (ID2BK input and ELYCL output)
19	TSAOM	OUT	Ink optimizer temperature sensor (diode) drive voltage
20	TSABK	OUT	Black head temperature sensor (diode) drive voltage
21	TEMP	IN	Printer temperature sensor (thermistor) detection voltage
22	HPS	IN	Home position detection
23	LEDON	OUT	Photo LED drive voltage
24-28	GND	...	GND

**CNHEAD2 (Carriage Cable Connector)**

Pin No.	Signal	IN/OUT	Function
1	INKOUT	IN	Ink-out detection
2	TSKCL	IN	Color head temperature sensor (diode) output voltage
3	TSKPH	IN	Photo head temperature sensor (diode) output voltage
4	LTRST	OUT	Latch reset
5	RANKCL	IN	Color head rank resistance detection
6	RANKPH	IN	Photo head rank resistance detection
7	IDATACL	OUT	Color head print data
8	IDATAPH	OUT	Photo head print data
9	HEATECL	OUT	Color head heat enable
10	HEATEPH	OUT	Photo head heat enable
11	ID1CL/ELMCL	IN/OUT	Color head index 1 detection/magenta ink-out detection pulse (ID1CL input and /ELMCL output)
12	BE2	OUT	Print data block output signal generation 3

Pin No.	Signal	IN/OUT	Function
13	ID1PH/ELMPH	IN/OUT	Photo head index 1 detection/magenta ink-out detection pulse (ID1PH input and /ELMPH output)
14	SUBHCL	OUT	Color head sub-heater drive
15	BE0	OUT	Pint data block output signal generation 1
16	SUBHPH	OUT	Photo head sub-heater drive
17	ID2CL/ELCCL	IN/OUT	Color head index 2 detection/cyan ink-out detection pulse (ID2CL input and ELCCL output)
18	ODDE	OUT	Black head and color head odd nozzle, and ink optimizer and photo head even nozzle heat enable
19	ID2PH/ELYPH	IN/OUT	Photo head index 2 detection/yellow ink-out detection pulse (ID2PH input and ELYPH output)
20	TSACL	OUT	Color head temperature sensor (diode) drive voltage
21	TSAPH	OUT	Photo head temperature sensor (diode) drive voltage
22	VDDH	OUT	Head logic drive voltage
23	GND	...	GND
24-29	VH	OUT	Head heater drive voltage (20.0 ± 0.03VDC)

### 7.2 Carriage Board

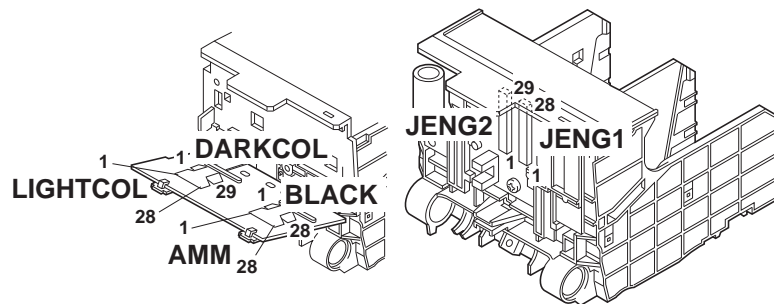

Figure 5-17 Carriage Board

The BLACK and AMM pins are connected, respectively, to the black head and ink optimizer head of the BC-60.

The DARKCOL and LIGHTCOL pins are connected as shown in Table 5-1.

TABLE 5-1 CONTACTS (DARK COL AND LIGHT COL)

	DARKCOL	LIGHTCOL
BC-61 installed	Color head	Not used
BC-62e Photo installed	Color head	Photo head

**JENG1 (Carriage Cable Connector)**

Pin No.	Signal	IN/OUT	Function
1-5	GND	...	GND
6	LEDON	IN	Photo LED drive voltage
7	HPS	OUT	Home position detection
8	TEMP	OUT	Printer temperature sensor (thermistor) detection voltage
9	TSABK	IN	Black head temperature sensor (diode) drive voltage
10	TSAOM	IN	Ink optimizer temperature sensor (diode) drive voltage
11	ID2BK/ELYCL	OUT/IN	Black head index 2 detection/color head yellow ink-out detection pulse (ID2BK input and ELYCL output)
12	EVENE	IN	Black head and color head even nozzle, and ink optimizer and photo head odd nozzle heat enable
13	ID2OM/ELOM	OUT/IN	Ink optimizer index 2 detection/ink-out detection pulse (ID2OM input and ELOM output)
14	SUBHBK	IN	Black head sub-heater drive
15	BE1	IN	Print data block output signal generation 2
16	SUBHOM	IN	Ink optimizer sub-heater drive
17	ID1BK/ELBK	OUT/IN	Black head index1 detection/ink-out detection pulse (ID1BK output and ELBK input)
18	DCLK	IN	Print data transfer clock
19	ID1OM	OUT/IN	Ink optimizer head index1 detection/photo head cyan ink-out detection pulse (ID1OM input and ELCPH output)
20	HEATEBK	IN	Black head heat enable
21	HEATEOM	IN	Ink optimizer heat enable
22	IDATABK	IN	Black head print data
23	IDATAOM	IN	Ink optimizer print data
24	RANKBK	OUT	Black head rank resistance detection
25	RANKOM	OUT	Ink optimizer rank resistance detection
26	LTCLK	IN	Print data latch timing specification
27	TSKBK	OUT	Black head temperature sensor (diode) output voltage
28	TSKOM	OUT	Ink optimizer temperature sensor (diode) output voltage

**JENG2 (Carriage Cable Connector)**

Pin No.	Signal	IN/OUT	Function
1-6	VH	IN	Head heater drive voltage (20.0 ± 0.3VDC)
7	GND	...	GND
8	VDDH	IN	Head logic drive voltage
9	TSAPH	IN	Photo head temperature sensor (diode) drive voltage
10	TSACL	IN	Color head temperature sensor (diode) drive voltage
11	ID2PH/ELYPH	OUT/IN	Photo head index 2 detection/yellow ink-out detection pulse (ID2PH output and ELYPHY input)
12	ODDE	IN	Black head and color head odd nozzle, and ink optimizer and photo head even nozzle heat enable
13	ID2CL/ELCCL	OUT/IN	Color head index 2 detection/cyan ink-out detection pulse (ID2CL output and ELCCL input)
14	SUBHPH	IN	Photo head sub-heater drive
15	BE0	IN	Print data block output signal generation 1
16	SUBHCL	IN	Color head sub-heater drive
17	ID1PH/ELMPH	OUT/IN	Photo head index 1 detection/magenta ink-out detection pulse (ID1PH output and /ELMPH input)
18	BE2	IN	Print data block output signal generation 3

Pin No.	Signal	IN/OUT	Function
19	ID1CL/ELMCL	OUT/IN	Color head index 1 detection/magenta ink-out detection pulse (ID1CL output and /ELMCL input)
20	HEATEPH	IN	Photo head heat enable
21	HEATECL	IN	Color head heat enable
22	IDATAPH	IN	Photo head print data
23	IDATACL	IN	Color head print data
24	RANKPH	OUT	Photo head rank resistance detection
25	RANKCL	OUT	Color head rank resistance detection
26	LTRST	IN	Latch reset
27	TSKPH	OUT	Photo head temperature sensor (diode) output voltage
28	TSKCL	OUT	Color head temperature sensor (diode) output voltage
29	INK	OUT	Ink-out detection

### BLACK (Cartridge Cable)

Pin No.	Signal	IN/OUT	Function
1	VH	OUT	Head drive voltage (20.0 ± 0.3VDC)
2	TSABK	OUT	Black head temperature sensor (diode) drive voltage
3	ID2BK	IN	Black head index 2 detection
4	SUBHBK	OUT	Black head sub-heater drive
5	ID1BK	IN	Black head index 1 detection
6	VDDH	OUT	Head logic drive voltage
7, 8	GND	...	GND
9	HEATEBK	OUT	Black head heat enable
10	INVBK	OUT	Black head print data block output signal output sequence inversion (permanently disabled)
11	ODDE	OUT	Black head and color head odd nozzle, and ink optimizer and photo head even nozzle heat enable
12	EVENE	OUT	Black head and color head even nozzle, and ink optimizer and photo head odd nozzle heat enable
13	BE0	OUT	Print data block output signal generation 1
14	VH	OUT	Head drive voltage (20.0 ± 0.3VDC)
15	BE1	OUT	Print data block output signal generation 2
16	IDATABK	OUT	Black head print data
17	BE2	OUT	Print data block output signal generation 3
18	DCLK	OUT	Print data transmission clock
19-21	GND	...	GND
22	LTCLK	OUT	Print data latch timing specifier
23	ELBK	OUT	Black head ink-out detection pulse
24	RANKBK	IN	Black head rank resistance detection
25	LTRST	OUT	Latch reset
26	TSKBK	IN	Black head temperature sensor (diode) output voltage
27	VH	OUT	Head drive voltage (20.0±0.3VDC)
28	Not used	...	...

**AMM (Cartridge Cable)**

Pin No.	Signal	IN/OUT	Function
1	VH	OUT	Head drive voltage (20.0 ± 0.3VDC)
2	TSAOM	OUT	Ink optimizer temperature sensor (diode) drive voltage
3	ID2OM	IN	Ink optimizer index 2 detection
4	SUBHOM	OUT	Ink optimizer sub-heater drive
5	ID1OM	IN	Ink optimizer index 1 detection (N.C.)
6	VDDH	OUT	Head logic drive voltage
7, 8	GND	...	GND
9	HEATEOM	OUT	Ink optimizer heat enable
10	INVOM	OUT	Ink optimizer print data block output signal output sequence inversion (permanently enabled)
11	EVENE	OUT	Black head and color head even nozzle, and ink optimizer and photo head odd nozzle heat enable
12	ODDE	OUT	Black head and color head odd nozzle, and ink optimizer and photo head even nozzle heat enable
13	BE0	OUT	Print data block output signal generation 1
14	VH	OUT	Head drive voltage (20.0 ± 0.3VDC)
15	BE1	OUT	Print data block output signal generation 2
16	IDATAOM	OUT	Ink optimizer print data
17	BE2	OUT	Print data block output signal generation 3
18	DCLK	OUT	Print data transmission clock
19-21	GND	...	GND
22	LTCLK	OUT	Print data latch timing specifier
23	ELOM	OUT	Ink optimizer ink-out detection pulse
24	RANKOM	IN	Ink optimizer rank resistance detection
25	LTRST	OUT	Latch reset
26	TSKOM	IN	Ink optimizer temperature sensor (diode) output voltage
27	VH	OUT	Head drive voltage (20.0±0.3VDC)
28	Not used	...	...

**DARKCOL (Cartridge Cable)**

Pin No.	Signal	IN/OUT	Function
1	PHANT	IN	Photo head ink-out detection (antenna voltage)
2	VH	OUT	Head drive voltage (20.0 ± 0.3VDC)
3	TSACL	OUT	Color head temperature sensor (diode) drive voltage
4	ID2CL/ELCCL	IN/OUT	Color head index 2 detection/cyan ink-out detection pulse (ID2CL input and ELCCL output)
5	SUBHCL	OUT	Color head sub-heater drive
6	ID1CL/ELMCL	IN/OUT	Color head index 1 detection/magenta ink-out detection pulse (ID1CL input and ELMCL output)
7	VDDH	OUT	Head logic drive voltage
8, 9	GND	...	GND
10	HEATECL	OUT	Color head heat enable
11	INVCL	OUT	Color head print data block output signal output sequence inversion (permanently disabled)
12	ODDE	OUT	Black head and color head odd nozzle, and ink optimizer and photo head even nozzle heat enable
13	EVENE	OUT	Black head and color head even nozzle and ink optimizer and photo head odd nozzle heat enable
14	BE0	OUT	Print data block output signal generation 1

Pin No.	Signal	IN/OUT	Function
15	VH	OUT	Head drive voltage (20.0 ± 0.3VDC)
16	BE1	OUT	Print data block output signal generation 2
17	IDATACL	OUT	Color head print data
18	BE2	OUT	Print data block output signal generation 3
19	DCLK	OUT	Print data transmission clock
20-22	GND	...	GND
23	LTCLK	OUT	Print data latch timing specifier
24	ELYCL	OUT	Color head yellow ink-out detection pulse
25	RANKCL	IN	Color head rank resistance detection
26	LTRST	OUT	Latch reset
27	TSKCL	IN	Color head temperature sensor (diode) output voltage
28	VH	OUT	Head drive voltage (20.0 ± 0.3VDC)
29	Not used	...	...

### LIGHTCOL (Cartridge Cable)

Pin No.	Signal	IN/OUT	Function
1	VH	OUT	Head drive voltage (20.0 ± 0.3VDC)
2	TSAPH	OUT	Photo head temperature sensor (diode) drive voltage
3	ID2PH/ELYPH	IN/OUT	Photo head index 2 detection/yellow ink-out detection pulse (ID2PH input and ELYPH output)
4	SUBHPH	OUT	Photo head sub-heater drive
5	ID1PH/ELMPH	IN/OUT	Photo head index 1 detection/magenta ink-out detection pulse (ID1PH input and ELMPH output)
6	VDDH	OUT	Head logic drive voltage
7, 8	GND	...	GND
9	HEATEPH	OUT	Photo head heat enable
10	INVPH	OUT	Photo head print data block output signal output sequence inversion (permanently enabled)
11	EVENE	OUT	Black head and color head even nozzle, and ink optimizer and photo head odd nozzle heat enable
12	ODDE	OUT	Black head and color head odd nozzle and ink optimizer and photo head even nozzle heat enable
13	BE0	OUT	Print data block output signal generation 1
14	VH	OUT	Head drive voltage (20.0 ± 0.3VDC)
15	BE1	OUT	Print data block output signal generation 2
16	IDATAPH	OUT	Photo head print data
17	BE2	OUT	Print data block output signal generation 3
18	DCLK	OUT	Print data transmission clock
19-21	GND	...	GND
22	LTCLK	OUT	Print data latch timing specifier
23	ELCPH	OUT	Photo head cyan ink-out detection pulse
24	RANKPH	IN	Photo head rank resistance detection
25	LTRST	OUT	Latch reset
26	TSKPH	IN	Photo head temperature sensor (diode) output voltage
27	VH	OUT	Head drive voltage (20.0 ± 0.3VDC)
28	Not used	...	...



# 8. CIRCUIT DIAGRAMS

## 8.1 Parts Layout

### 8.1.1 Logic board

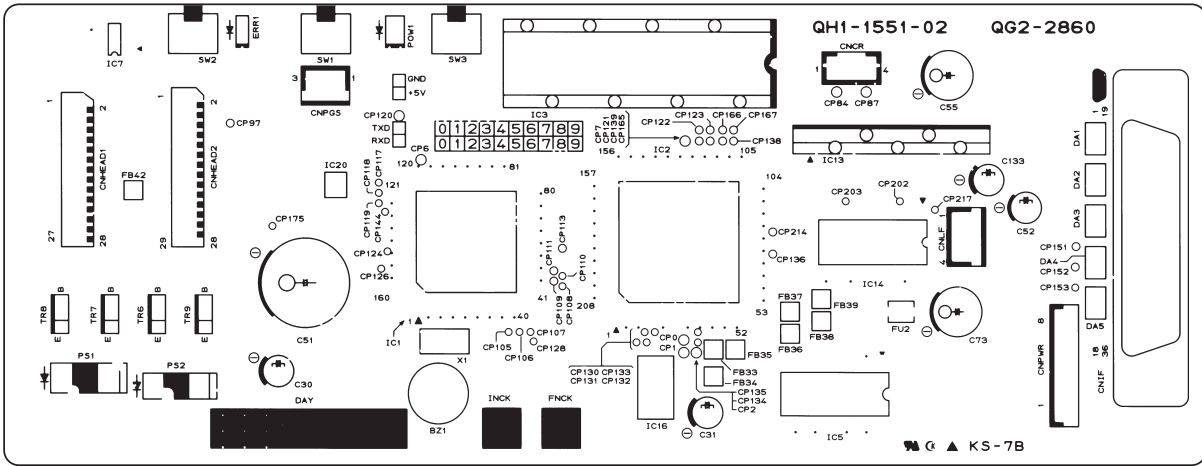

Figure 5-18 Logic Board (Face)

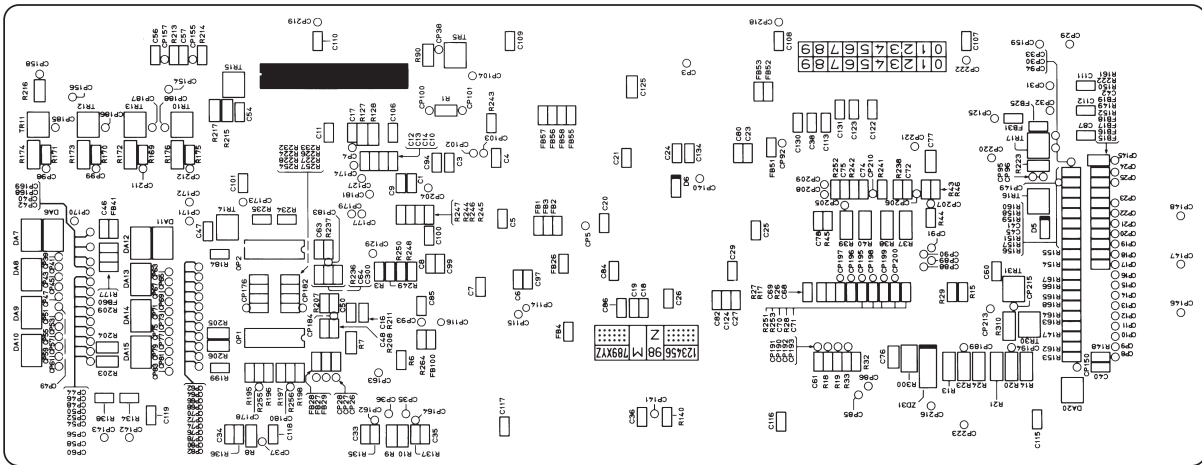

Figure 5-19 Component Board (Back)



8.1.2 Carriage board

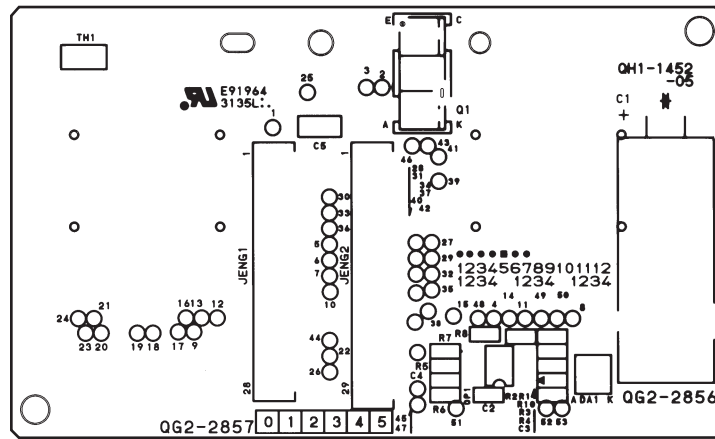

Figure 5-20 Carriage Board (Face)

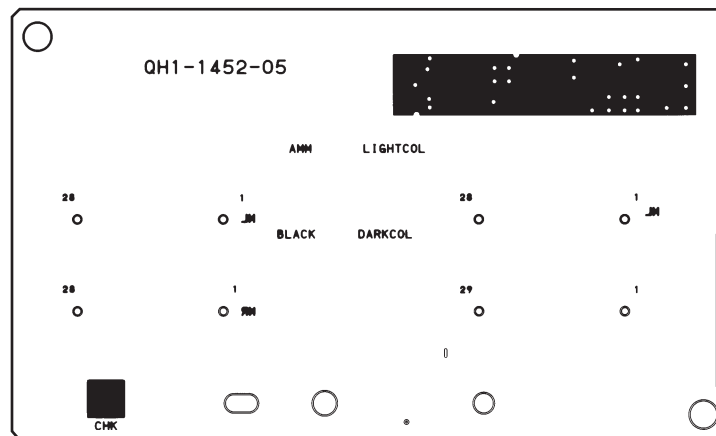
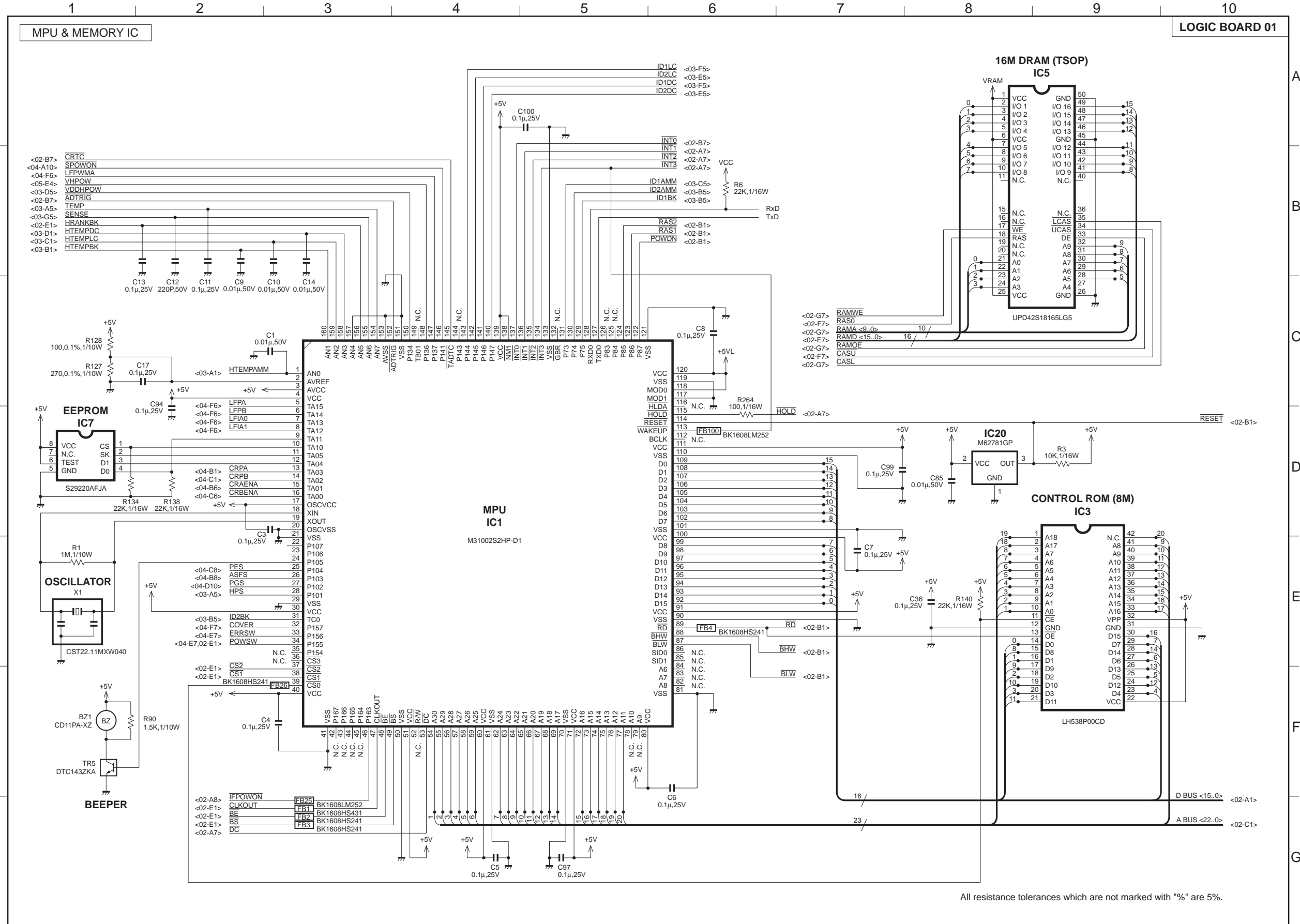
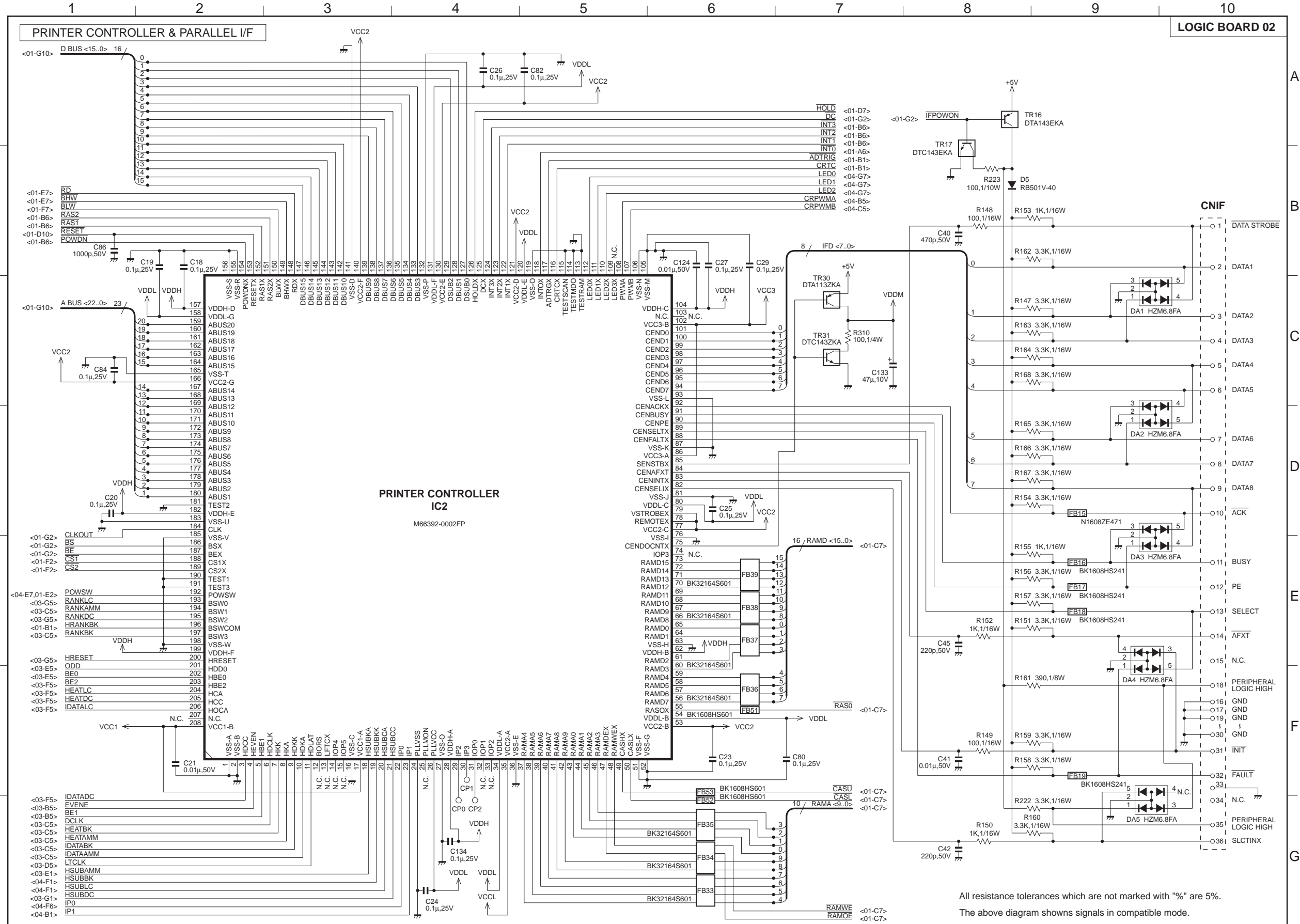

Figure 5-21 Carriage Board (Back)

This page intentionally left blank

8.2 Circuit Diagrams  
8.2.1 Logic board





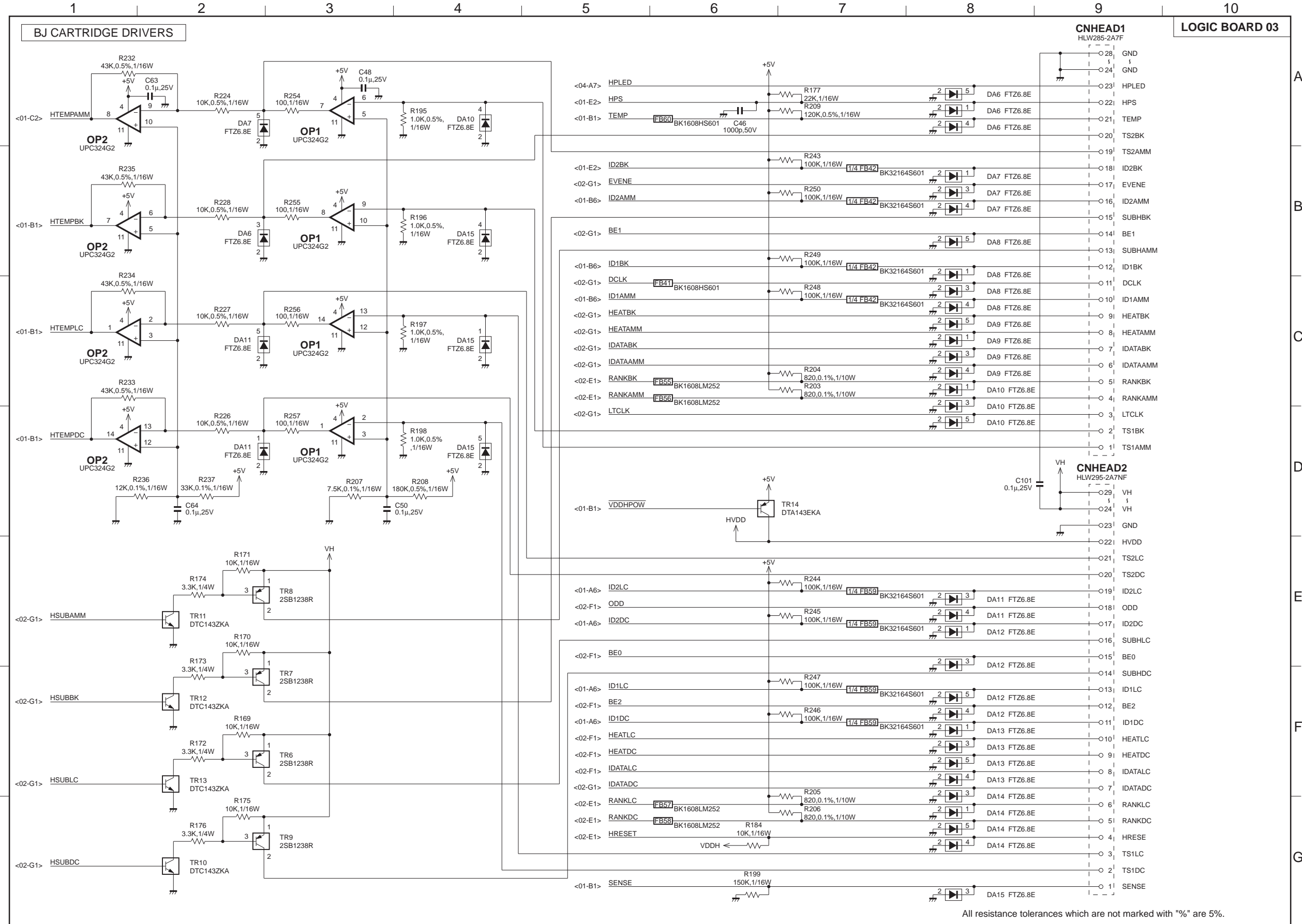

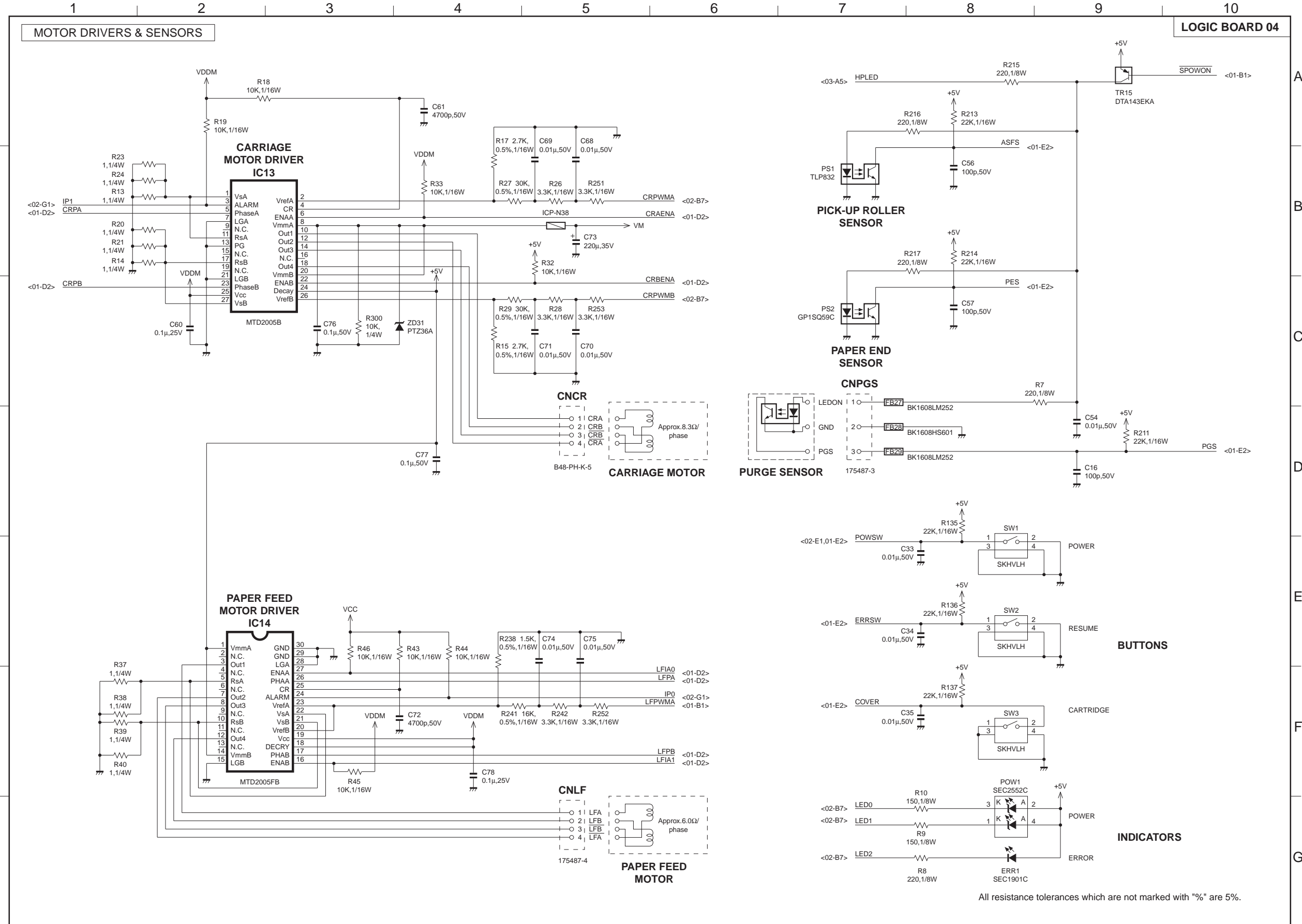

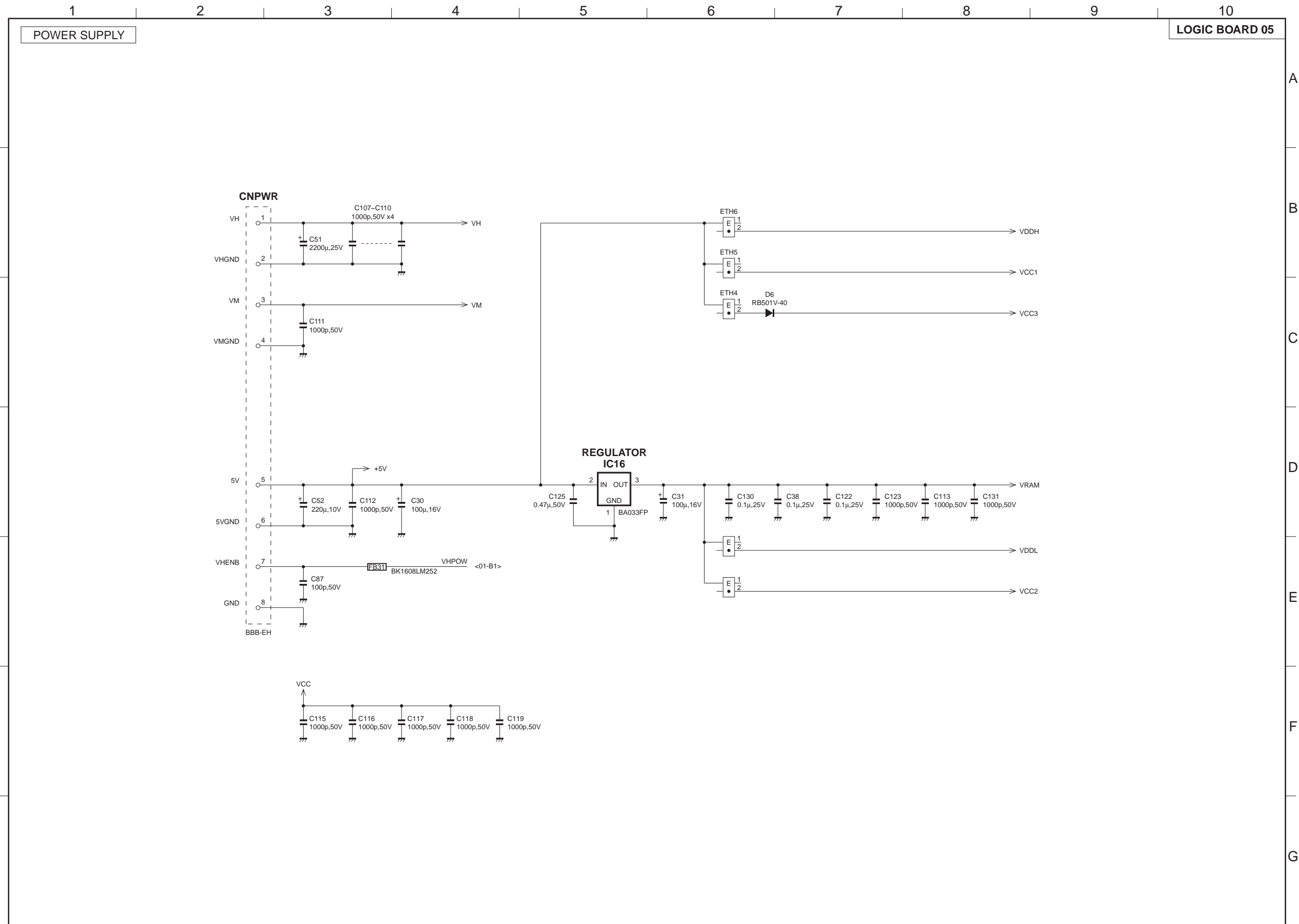







The printing paper contains  
70% waste paper.

# Canon